

G. L. RIDER.

Check-Row Attachment for Corn-Planters.

No. 207,683.

Patented Sept. 3, 1878.

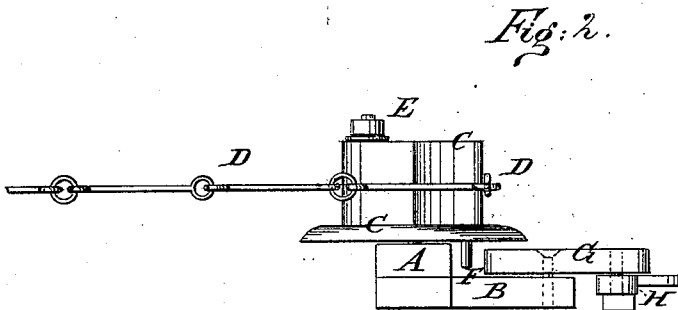
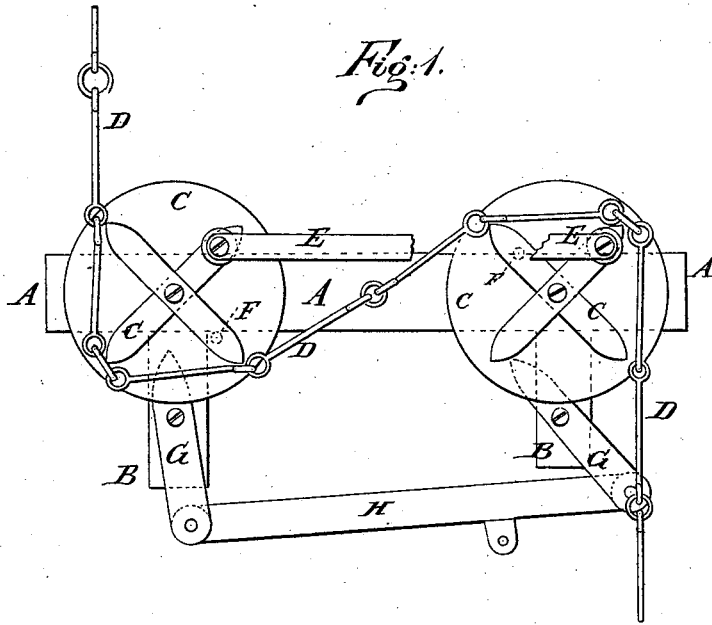

WITNESSES:

*Chas. Viola*  
*b. Sedgwick*

INVENTOR:

*G. L. Rider*  
BY *Munnick*

ATTORNEYS.

# UNITED STATES PATENT OFFICE

GEORGE L. RIDER, OF KENT, IOWA.

## IMPROVEMENT IN CHECK-ROW ATTACHMENTS FOR CORN-PLANTERS.

Specification forming part of Letters Patent No. **207,683**, dated September 3, 1878; application filed March 25, 1878.

*To all whom it may concern:*

Be it known that I, GEORGE L. RIDER, of Kent, in the county of Union and State of Iowa, have invented a new and useful Improvement in Check-Row Attachments for Corn-Planters, of which the following is a specification:

Figure 1 is a top view of my improved device. Fig. 2 is a side view of the same.

Similar letters of reference indicate corresponding parts.

The object of this invention is to furnish an improved check-row attachment for any ordinary corn-planter, which shall be so constructed as to be practically unaffected by changes of the weather, and which, at the same time, shall be simple in construction, strong, durable, not liable to get out of order, and inexpensive in manufacture.

The present invention consists in the construction and combination of parts, which will be hereinafter fully described, and then pointed out in the claim.

A B represent a part of the frame of a corn-planter, or bars to be attached to said frame.

To the end parts of the bar A are pivoted two reels, C, the arms of which are made pointed or forked to receive the joints of the wire chain D, which is stretched across the field, and the links of which are made two feet, more or less, in length, or of a length equal to the distance between the ends of the arms of the reels C. The reels are connected by a cross-bar, E, the ends of which are pivoted to the correspond-

ing arms of the two reels C, so that the said reels may move exactly together.

To the opposite parts of the lower ends of the two reels C are attached pins or blocks F, which strike alternately against the ends of the levers G and turn them upon their pivots. The levers G are pivoted to the bars B, and to their rear ends are pivoted the ends of the cross-bar H, which is connected with the dropping-slide of the planter, which slide will thus be operated twice at each revolution of the reels C.

By attaching pins or blocks F to each arm of the reels C the seed will be dropped in drills. The chain D should have a number of swivels formed in it to prevent it from twisting or kinking.

I am aware that a chain composed of long links has been used in a check-row planter in place of the knotted cord or rope generally employed for operating the seeding devices.

Having thus described my invention, I claim as new and desire to secure by Letters Patent—

In a check-row planter, the combination of the armed reels C, connecting-bar E, pins or blocks F, levers G, and cross-bar H with the frame-work A B and the chain D, as and for the purpose set forth.

GEORGE L. RIDER.

Witnesses:

WILLIAM MILLER,  
H. A. TAYLOR.