

J. TAYLOR.
Sand Papering Machine.

No. 207,691.

Patented Sept. 3, 1878.

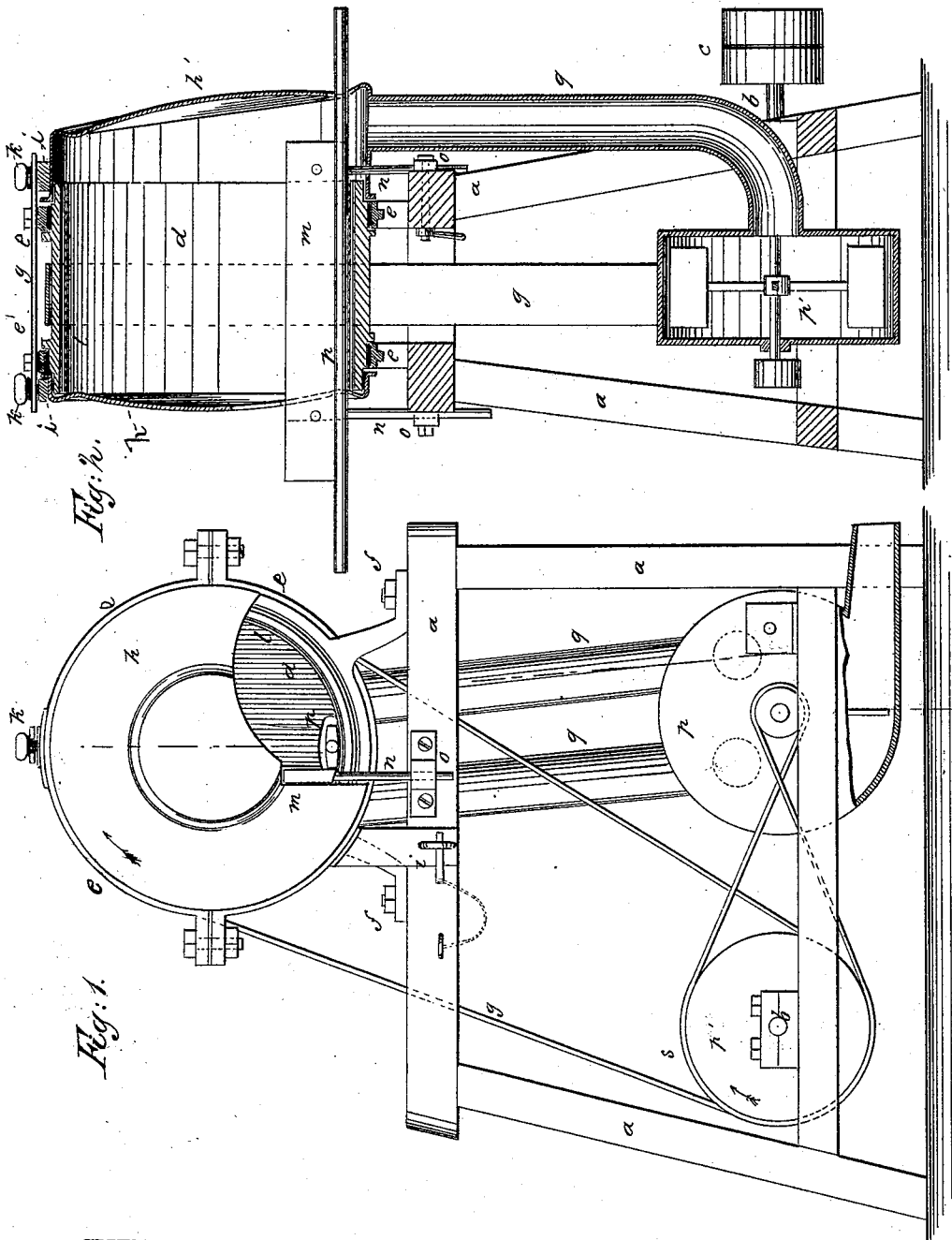

WITNESSES:

Cras. Nida
G. Sedgwick

INVENTOR:

J. Taylor
BY *Munn & Co*

ATTORNEYS.

UNITED STATES PATENT OFFICE.

JOSEPH TAYLOR, OF NEW ORLEANS, LOUISIANA.

IMPROVEMENT IN SANDPAPERING-MACHINES.

Specification forming part of Letters Patent No. **207,691**, dated September 3, 1878; application filed June 27, 1878.

To all whom it may concern:

Be it known that I, JOSEPH TAYLOR, of New Orleans, in the parish of Orleans and State of Louisiana, have invented a new and useful Improvement in Machines for Polishing Blind-Slats, &c., of which the following is a specification:

Blind-slats are cut out by machinery, and the surface of them is left by the machine in a rough state, so that they must be sandpapered and polished to give them a good finish.

The object of my invention is to furnish a machine for sandpapering or polishing the surface of blind-slats or other articles, whereby the work may be done neatly and with great facility.

I employ a polishing wheel or drum rotated by competent power, and having its inner surface lined with sand or emery paper or any other polishing substances.

The articles to be polished are placed against a guide or rest next to the polishing-surface, and moved back and forth by hand to polish them. An exhaust-blower is connected with the polishing-wheel to draw away the dust and particles removed by the wheel from the surface under operation.

In the drawing, Figure 1 is a side elevation of the polishing-machine, and Fig. 2 is a vertical section through the polishing-wheel.

Similar letters of reference indicate corresponding parts.

a a is the supporting frame or stand of the machine. *b* is a shaft, mounted in bearings on the frame *a*, and carrying the fast and loose pulleys *c*, for driving the machine, by a belt from the motor.

The polishing-wheel consists of a hollow cylinder, *d*, of wood or metal, supported loosely in rings or bearings *e*, which are bolted fast at *f* on the top of the frame *a*. The cylinder *d* is revolved in the bearings *e* by a belt, *g*, from a pulley, *s*, on the shaft *b*.

h h' are heads for the cylinder *d*, made of metal or other material, and held in place by staples *i* and screws *k*, so that they may be removed at pleasure to obtain access to the interior of the cylinder *d*. These heads serve to retain the dust made by the machine and keep it from flying about the room.

The interior surface of the cylinder or polishing-wheel *d* is lined with sand-paper, emery-paper, or other polishing material, and this may be attached in sheets to the wheel *d* by gluing or otherwise, as shown at *l*.

m is a rest or guide passing through the wheel *d* from side to side, and held by rods *n*, which are supported adjustably in bearings *o* by a thumb-screw, so that the rest *m* may be raised and lowered. *p* is an exhaust-blower fixed to the frame *a*, and operated by a belt from the pulley *p'* on the shaft *b*. *q q* are pipes from the blower *p*, passing through the head *h'* of the cylinder *d*. The head *h* of the cylinder *d* is cut away sufficiently to allow the workman to handle the work within the cylinder, and the head *h'* has an opening opposite thereto to allow a blind-slat to pass through.

In operating the machine, a blind-slat is laid across the bottom of the wheel *d*, against the rest *m*, as shown at *r*, and then, by moving the slat slightly back and forth, it is polished by the polishing-surface *l*. The blower *p* draws away the dust from the machine while the work is being done. The inner circumference of the wheel *d* conforms to the curve of the slat, thereby aiding in giving the proper shape to the slat.

It is to be understood that this machine may be used for other purposes than polishing blind-slats, as any article of wood or metal can be placed within the machine for abrading or polishing its surface. The finish put upon the surface will depend upon the fineness of the material used upon the wheel *d*.

Having thus described my invention, I claim as new and desire to secure by Letters Patent—

1. The combination of a rotary drum having polishing-surface on inside, a movable rest, and an exhaust-blower, as shown and described, for the purpose specified.

2. The blower *p*, in combination with the polishing-drum *d* and heads *h h'*, substantially as and for the purposes set forth.

JOSEPH TAYLOR.

Witnesses:

FRED. RÜB,
P. LASSALLE.