

C. R. VAILLANT.  
Steam-Gage.

No. 207,696.

Patented Sept. 3, 1878.

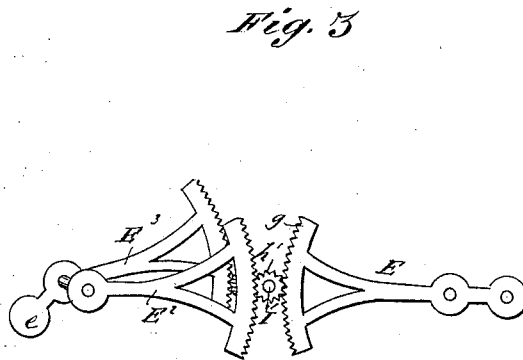
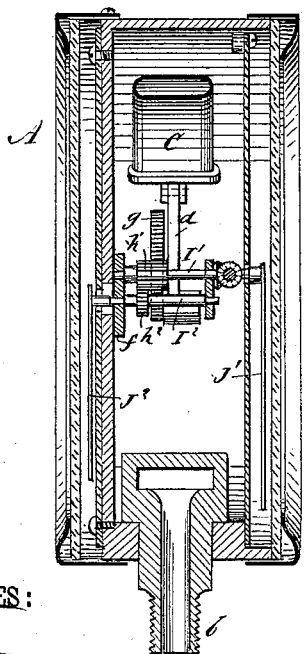
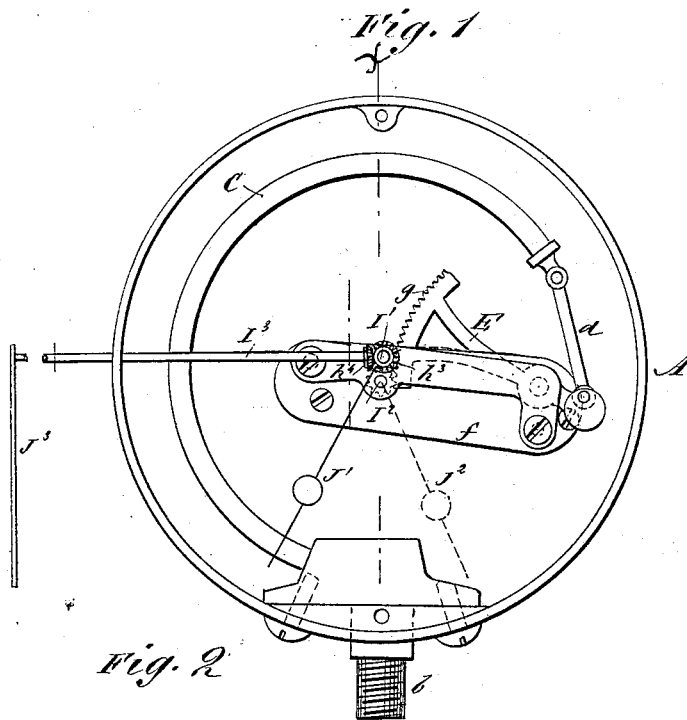

WITNESSES:  
*C. Newell*  
*C. Sedgwick*

INVENTOR:  
*C. R. Vaillant*  
BY *Munn & Co*

ATTORNEYS.

# UNITED STATES PATENT OFFICE.

CHARLES R. VAILLANT, OF MOBILE, ALABAMA.

## IMPROVEMENT IN STEAM-GAGES.

Specification forming part of Letters Patent No. 207,696, dated September 3, 1878; application filed May 15, 1878.

*To all whom it may concern:*

Be it known that I, CHARLES R. VAILLANT, of Mobile, in the county of Mobile and State of Alabama, have invented a new and useful Improvement in Steam and Pressure Gages, of which the following is a specification:

My invention relates to certain improvements the object of which is to enable the pressure of steam in a boiler to be indicated so as to be seen simultaneously by two or more persons located at different points.

It is often desirable, and sometimes very important, that the steam-gage should be consulted very frequently, not only by the engineer in charge of the engine and boiler, but by the proprietor or superintendent of the establishment in which they are located, or by some person assigned to such duty, and this for various reasons, some of which are obvious—as, for instance, in the event of having a strange engineer, or one concerning whom lack of confidence exists—in which case the desired object would be better attained if the inspection could be made without the knowledge of the engineer.

My invention provides for such and similar emergencies; and to this end the invention consists, essentially, in the combination, with a steam-gage and its indicator and dial, of one, two, or more additional indicators and dials, arranged in different positions from the primary ones, and adapted to be placed at considerable distances therefrom, said indicators and dials being so connected and arranged with relation to each other as to cause them to operate simultaneously and in the same proper numerical direction.

The invention is applicable to steam-gages of any of the ordinary descriptions, in which the indicator is operated by the action of a rack, or toothed rod, or arm, on a pinion carried by the indicator-shaft.

The accompanying drawing represents the invention applied to a gage, in which the indicator is operated by the engagement with a pinion carried by the indicator-shaft of a toothed arc on a lever connected by a link with an expansible hollow arm communicating with a pipe leading from the steam-boiler.

In said drawing, Figure 1 represents a vertical sectional view of a steam-gage embody-

ing my improvements; Fig. 2, a vertical section taken in the line *x x* of Fig. 1, and Fig. 3 a modification.

Similar letters of reference indicate corresponding parts.

The chamber A, containing the gage mechanism, is of the usual description. A pipe, *b*, from the steam-boiler communicates with an expansible hollow curved arm, C, the free end of which is connected by a link, *d*, with one end of a lever, E, pivoted in a frame, *f*, which frame also furnishes bearings for the indicator-shafts.

The other end of the lever E carries a curved rack, *g*, which meshes into a pinion, *h*<sup>1</sup>, on the main or primary indicator-shaft I<sup>1</sup>, carrying the primary indicator J<sup>1</sup>. Immediately adjoining the primary shaft I<sup>1</sup>, and parallel therewith, is a secondary shaft, I<sup>2</sup>, carrying a secondary indicator, J<sup>2</sup>, (shown in dotted lines) at the opposite end from the primary indicator. On the secondary shaft I<sup>2</sup> is a pinion, *h*<sup>2</sup>, gearing with the pinion *h*<sup>1</sup>. When the action of the rack *g* on the pinion *h*<sup>1</sup> moves the indicator J<sup>1</sup> in one direction, the action of said pinion *h*<sup>1</sup> on the secondary pinion *h*<sup>2</sup> moves the indicator J<sup>2</sup> in the opposite direction.

Thus the two indicators are made to move simultaneously in opposite directions, and at the same time to indicate in the proper numerical directions on two separate dials the pressure of steam in the boiler. The two dials may be placed in two separate rooms, with a partition between them, and the secondary shaft I<sup>2</sup> may be made long enough to extend the required distance.

When more than one extra dial and indicator are required, one of the indicator-shafts is provided with a bevel-pinion, *h*<sup>3</sup>, which drives a bevel-pinion, *h*<sup>4</sup>, on a third shaft, I<sup>3</sup>, carrying a third indicator, J<sup>3</sup>. The shaft I<sup>3</sup> may extend either horizontally, so as to enter a room on the same floor with the gage, or upwardly, so as to enter a room on the floor above.

In the modification shown in Fig. 3, the pinion *h*<sup>1</sup>, carried by the main shaft I<sup>1</sup>, drives a second toothed sector, E<sup>2</sup>, which has a third toothed sector, E<sup>3</sup>, rigidly attached to its shaft, so as to move simultaneously with it. This

third sector drives the secondary pinion and indicator-shaft, instead of having the first pinion continued wide enough to engage with the secondary one, as above described. By this means the two indicator-shafts may be placed in the same central line, instead of side by side. The sector  $E^3$  may be provided with a counter-balance,  $e$ .

Having thus described my invention, I claim as new and desire to secure by Letters Patent—

The combination, in a gage, with the indicators  $J^1 J^2$ , of the steam-pipe  $b$ , expansible curved arm  $C$ , link  $d$ , lever  $E$ , curved rack  $g$ , pinions  $h^1 h^2$ , and shafts  $I^1 I^2$ , as and for the purpose specified.

CHARLES RAUL VAILLANT.

Witnesses:

W. P. GAZZAM,  
CHAS. W. GAZZAM.

*1.000 words.*