

J. B. DOUGHERTY.
Hoop.

No. 207,721.

Patented Sept. 3, 1878.

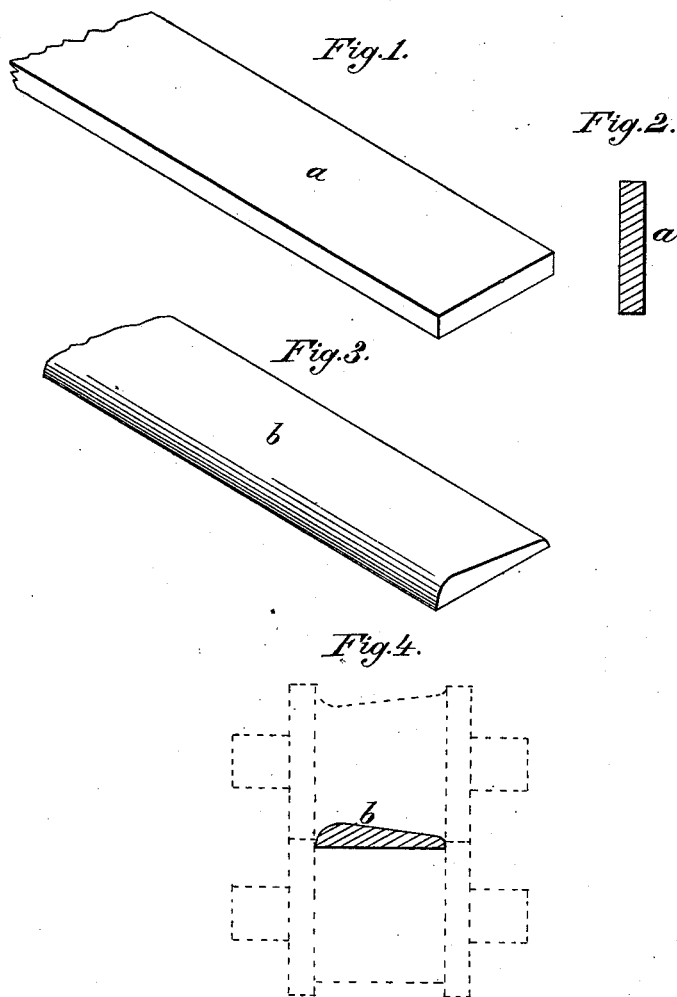

Attest:
F. H. Schott,
D. P. Howl

Inventor:
John B. Dougherty
J. C. Foster & Co.
attys

UNITED STATES PATENT OFFICE.

JOHN B. DOUGHERTY, OF ROCHESTER, NEW YORK.

IMPROVEMENT IN HOOPS.

Specification forming part of Letters Patent No. 207,721, dated September 3, 1878; application filed July 2, 1878.

To all whom it may concern:

Be it known that I, JOHN B. DOUGHERTY, of Rochester, in the county of Monroe and State of New York, have invented certain new and useful Improvements in Hoops; and I do hereby declare that the following is a full, clear, and exact description thereof, which will enable others skilled in the art to which it appertains to make and use the same, reference being had to the accompanying drawings, and to letters of reference marked thereon, which form a part of this specification.

The object of this invention is to produce a completely-finished hoop with beveled outer surface and rounded edges from the rough rectangular blank as it comes from the hoop-cutter, without waste of its substance; and this I accomplish by pressing the blank into the desired form through the agency of suitably-shaped dies, either rotating or stationary.

In the accompanying drawings, Figure 1 is a perspective view of a portion of a hoop-blank as it comes from the log. Fig. 2 is a transverse section of the same. Fig. 3 is a perspective view of a portion of a hoop after being pressed into the desired shape; and Fig. 4 is a transverse section of the finished hoop.

These hoop-blanks are usually formed by cutting from a rotating log a veneer of the same thickness as the blank, which is then cut into strips of the desired width, or they may be cut from the periphery of the log by means of two reciprocating knives acting alternately and at right angles to each other; but, by whatever means produced, their surfaces are left rough and the outer angles sharp, requiring shaping, planing, and trimming to give the hoop the form and surface needed for finished work. This trimming and shaping process, as ordinarily performed, removes a large percentage of the material, thus greatly weakening the hoop as well as wasting its substance.

In carrying out my invention, the blank *a* (shown in Figs. 1 and 2) is passed between a pair of rotating dies or rolls, the periphery of which, as indicated by the dotted lines in Fig. 4, have a contour identical with a section of the finished hoop. These dies, as they rotate, draw the blank into the groove between them, compressing it into the shape of the round edge-finished and smooth-surfaced beveled hoop *b*, and this is accomplished without waste of material by a simple compacting of the fiber, leaving it of the full strength of the blank from which it is produced.

Other means may be employed for pressing and forming the hoop than the grooved rolls above described without departing from my invention, as I do not limit myself to any especial devices for applying the pressure needed in compacting and forming the hoop. If the hoop is to be used upon articles which are exposed to the weather, or liable in other ways to become wet, the surface may be covered with a coat of water-proof varnish, paint, or other substance, which shall prevent it from imbibing moisture; but when the hoops are used upon rough articles, or those likely to remain dry, this water-proof coating is unnecessary.

Having thus described my invention, I claim as new, and desire to secure by Letters Patent, the following:

A wooden hoop having compacted fibers and finished compressed form, substantially as and for the purpose specified.

In testimony that I claim the foregoing as my own I hereunto affix my signature in presence of two witnesses.

JOHN B. DOUGHERTY.

Witnesses:

HORACE G. PIERCE,
W. I. LUDLOW.