

S. R. KING.  
Machine for Erecting Frame Structures.

No. 207,746.

Patented Sept. 3, 1878.

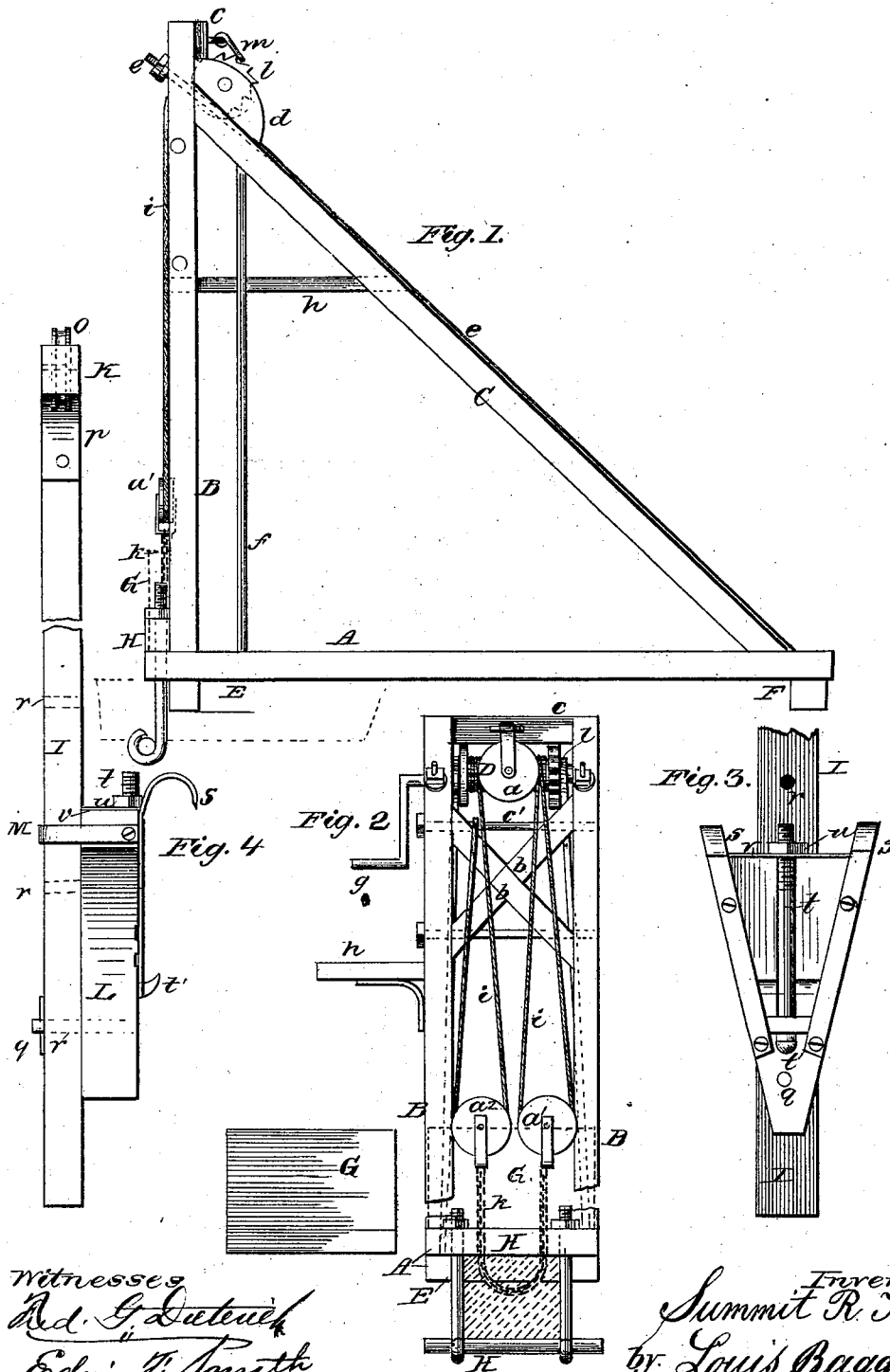

Witnesses  
*Ed. G. Duteuch*  
*Edwin T. Smith*

Inventor  
*Summit R. King*  
 by *Louis Bagger & Co.*  
*his atty.*

# UNITED STATES PATENT OFFICE.

SUMMIT R. KING, OF MASON, MICHIGAN.

## IMPROVEMENT IN MACHINES FOR ERECTING FRAME STRUCTURES.

Specification forming part of Letters Patent No. 207,746, dated September 3, 1878; application filed June 13, 1878.

*To all whom it may concern:*

Be it known that I, SUMMIT R. KING, of Mason, in the county of Ingham and State of Michigan, have invented certain new and useful Improvements in Machines for Erecting Frame Structures; and I do hereby declare that the following is a full, clear, and exact description thereof, which will enable others skilled in the art to which it appertains to make and use the same, reference being had to the accompanying drawings, which form a part of this specification, and in which—

Figure 1 is a side elevation. Fig. 2 is a front view. Fig. 3 is a rear elevation of the lower part of the swinging crane for raising plates and purlin-bents, which is used in combination with and forms a part of my invention; and Fig. 4 is a side view of the same.

Similar letters of reference indicate corresponding parts in all the figures.

This invention relates to devices for erecting the frames and bents of structures, having for its object to save time, labor, and avoid the danger incident to the usual method of raising the bents by ordinary cranes and tackle; and it consists in an improved construction and combination of parts, substantially as hereinafter more fully described.

In the drawing, A A are the bottom planks, B B the uprights, and C C the braces. The upper parts of the standards B B are united and strengthened by the cross-braces *b b* and the cap-piece or beam *c*, upon which the sheave or pulley *a* is suspended. *d d* are two blocks, in which the journals of the hoisting-drum D are pivoted, and which also serve as a rest or support for the cap-beam *c*. These blocks are grooved or recessed on their under side to make room for the brace-rods *e e*. *f f* are vertical brace-rods, which extend from the bottom pieces, A A, up to drum D, around the shaft or axle of which their ends are bent, so as to form hooks, by means of which the upper and lower parts of the structure are firmly bound together.

Drum D is operated by a crank, *g*, and for the convenience of the men working the machine a foot-board or platform, *h*, is placed on one side of the machine a suitable distance below the crank. The hoisting-rope *i* passes from drum D through the sheave or pulley *a*<sup>1</sup>,

and up around pulley *a*, which is suspended upon the cap-beam *c*, and then down through another pulley, *a*<sup>2</sup>, and up again to a rod or cross-piece, *c*<sup>1</sup>, below the cap-beam, to which its end is secured. The sheaves *a*<sup>1</sup> and *a*<sup>2</sup> are united by a short chain, *k*, which forms a rest for the posts or uprights of the bents to be raised, as hereinafter described in describing the operation of the machine.

*l* is a ratchet-wheel, secured at one end of drum D, which engages with a pivoted keeper, *m*, so as to prevent the drum from turning in the wrong direction and keep the bent or frame, during the operation of hoisting, in any given position when the crank is released. A pawl-and-ratchet attachment may be substituted for the wheel *l* and pivoted keeper *m*.

Two of these machines, both constructed exactly alike, are used in erecting a frame, one being placed at each end of the bent by placing the bottom timbers, A A, across the sill, a block, E, being placed under the front part, and another similar block, F, under the rear part, of the machine, after which the heel of this is fastened down upon the sill by means of the clamp-block H.

G is a block, which is placed in front of the machine for the uprights or posts of the bents to rest against. The two end posts of the bent to be raised are secured in the chains *k*, the same distance from the foot of the posts as the height of the machines, after which the bent is raised into a vertical position by turning the cranks of the hoisting-drums, so that both ends or sides of the bent shall be raised evenly.

To place the purlin bents and plates in position I employ a T-shaped crane, which consists of three parts—viz., an upright tilting beam, I, having at its top an arm or cross-piece, K, and a wedge-shaped block, L, pivoted to its lower end.

Arm K has a sheave, *o o'*, at each end, and is firmly secured to the upright I by braces *p p*. The lower end of the stem or upright I has a series of perforations, *r r r*, by means of which this upright may be pivoted adjustably upon a pin, *g*, projecting from the lower pointed end of the wedge-block L.

M is a keeper, made of iron, which spans the face of the upper wide part of block L, and

through which the upright I is passed. This keeper will control the motion of upright I and prevent it from swinging too far in either direction. Upon the back part of block L is bolted two stout iron bars, bent at the top to form hooks *s s*, the edges of which are sharpened and form one side or part of a clamp, the other part or jaw of which is formed by a rod, *t*, which slides in a groove or recess formed in the middle of block L, and terminates at its lower end in a pointed hook, *t'*, while its upper end is screw-threaded and passes through a nut, *u*, which works against a plate, *v*, bolted upon the top of block L, across the groove in which the rod or bolt *t* is inserted and slides, and which said plate is perforated to allow the screw-threaded end of bolt *t* to pass through.

This part of my invention is used as follows: After the bents have been erected and secured, so as to form the frame without the roof, the fastening block or clamp H is shifted from the heel to the front part of the machine, as shown in Fig. 2, for the purpose of preventing motion laterally by firmly anchoring the front part of the machine, which carries the hoisting-tackle, upon the sill. Next, block L is clamped upon the top cross-piece or beam of the end bent, near the end post, by clamping the beam between the hooks *s s t'*, so as to hold block L, which carries the swinging crane I K firmly in place. Upright I having been properly adjusted (according to the height the roof is to have) in block L, by means of the perforations *r* and pin *g*, the hoisting-rope *w* is removed from pulleys *a<sup>1</sup> a<sup>2</sup>* and passed direct from the drum through sheave *o*, across arm K from one end to the other, and down through sheave *o'*, after which the end is secured to the plate or purlin-bent which is to be raised and placed in position. As in the case of the cranes for raising the bents, two of these purlin-cranes are used, one at each end of the frame, and the plate or purlin-bent is raised by turning the cranks of drums D (one on each side) in the same manner as raising the bents.

By the use of my invention the frames of barns, dwelling-houses, or other structures, may be raised safely and expeditiously, requiring the assistance of only a few hands. It saves time, labor, and expense, and avoids danger to life and limb, as in cases where ordinary tackle is used, resulting frequently in accidents to the workmen and damage to the structure.

Having thus described my invention, I claim and desire to secure by Letters Patent of the United States—

1. The machine for raising the bents of frame structures herein described, consisting of the crane-frame A A, B B, C C, having brace-rods *e e f f*, cross-brace *b b*, and cap-piece *c*, in combination with the hoisting-drum D, rope *w*, and pulleys *a a<sup>1</sup> a<sup>2</sup>*, the two last of which are united by the chain-rest *k*, substantially as for the purpose herein shown and described.

2. The combination of the swinging upright I, having cross-piece K, carrying the pulleys *o o'*, with the wedge-block L, having keeper M and pivoting-pin *g*, substantially as and for the purpose herein shown and described.

3. The wedge-shaped clamp-block L, provided on one side with the keeper M and pivot *g*, and on the other with the stationary clamping-hooks *s s* and adjustable sliding bolt *t*, having clamping-hook *t'*, substantially as and for the purpose herein shown and described.

4. The combination of the hoisting frame A A, B B, C C, having drum D, with the adjustable tilting frame, consisting of parts I K L, and hoisting-rope *w*, all constructed and combined to operate substantially as and for the purpose hereinbefore set forth.

In testimony that I claim the foregoing as my own I have hereto affixed my signature in presence of two witnesses.

SUMMIT R. KING.

Witnesses:

J. B. STRICKLAND,  
MARIA TYLER.