

W. LEVIN.
Treadle.

No. 207,750.

Patented Sept. 3, 1878.

Fig. 1.

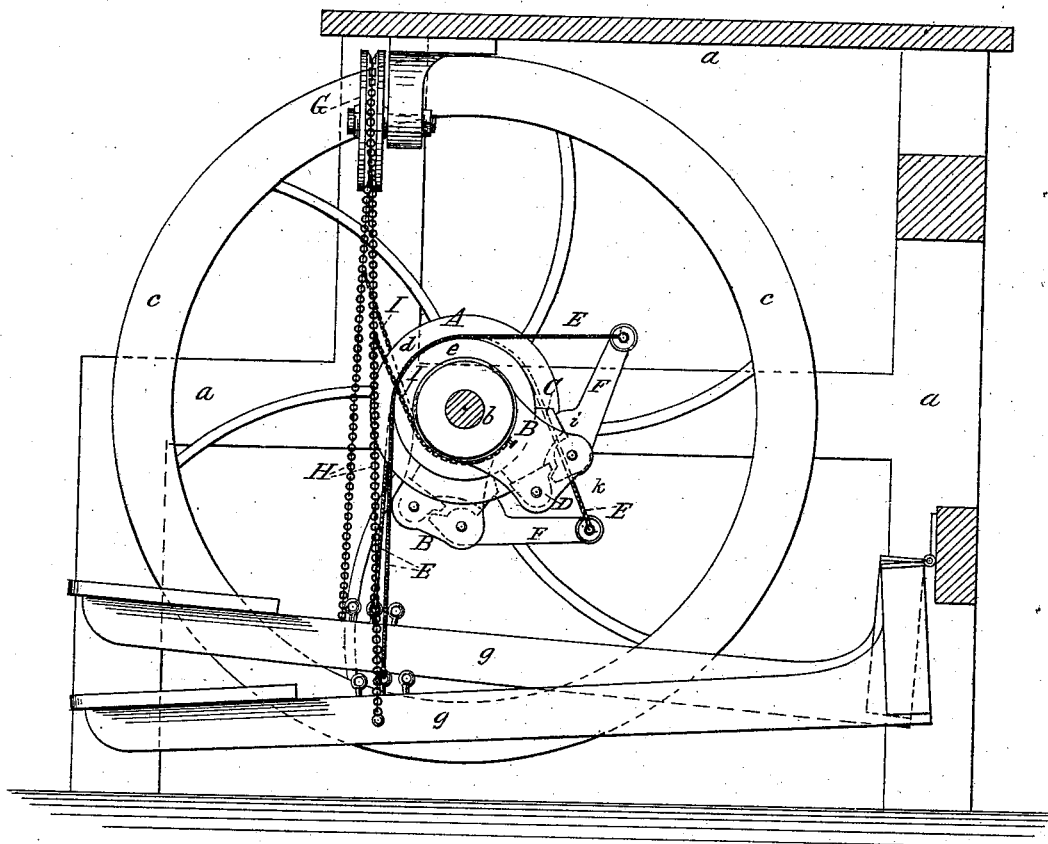

Attest:

Edward H. Wales,
Chas. W. Higgins.

Inventor

Wm. Levin

by his Attorneys:

S. H. Wales & Son

W. LEVIN.
Treadle.

No. 207,750.

Patented Sept. 3, 1878.

Fig. 2.

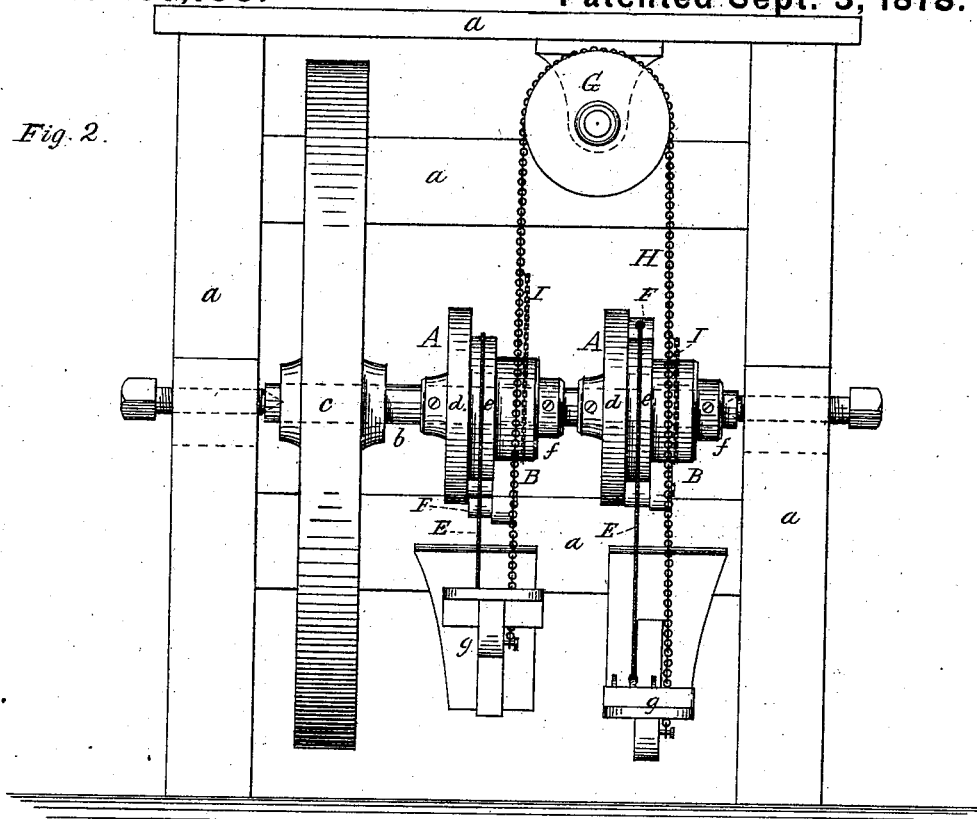

Fig. 3.

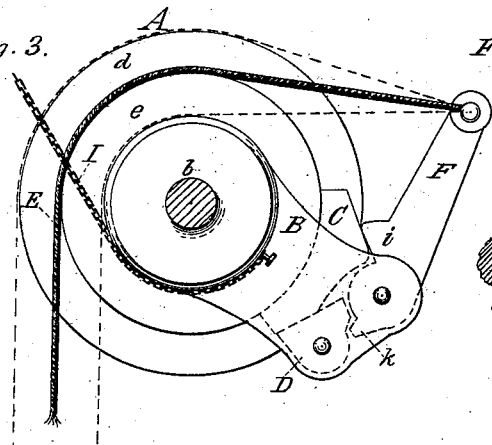
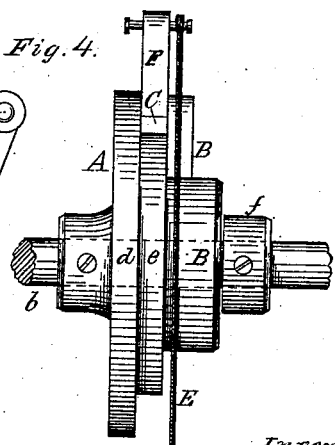

Fig. 4.



Attest:

Edward H. Wales
Chas. M. Higgins.

Inventor:

Wm. Levin
by his Attorneys:
S. H. Wales & Son

UNITED STATES PATENT OFFICE.

WILLIAM LEVIN, OF NEW YORK, N. Y.

IMPROVEMENT IN TREADLES.

Specification forming part of Letters Patent No. **207,750**, dated September 3, 1878; application filed April 8, 1878.

To all whom it may concern:

Be it known that I, WILLIAM LEVIN, of New York city, have invented certain new and useful Improvements in Treadle or Manual Power Machine, of which the following is a specification:

The aim of my invention is, mainly, to provide an improved manual-power motor, which shall enable the operator to utilize his whole weight and the whole or any part of his strength in the generation of the power, and with the least fatigue.

My invention relates to that class of manual powers or treadle mechanisms where an intermittingly-acting ratchet or clutch is employed to continuously actuate the fly-wheel in lieu of a crank.

Heretofore devices of this class have been generally single-acting, of a character adapted for light work, and not designed to utilize the weight of the operator in the exertion of the power.

In my invention I employ a double arrangement of treadles and clutches designed to receive the full weight of the operator, which is exerted alternately on each treadle by a natural stepping motion, transferring the weight from one treadle to the other, and which may be exerted continuously or at short or long intervals of action, with intervening long or short intervals of rest.

My invention is embodied in an intermittingly-acting friction clutch or ratchet of improved construction, actuated by the treadle to revolve the fly-wheel; in the combination therewith of a pulley-wheel, to which the clutch connects, formed with a series of varying diameters, over which the cord connecting clutch or treadle may be passed to vary the speed and power; and in the combination, with double alternating treadles and friction-clutches, of an independent unyielding cord or chain, positively reciprocating the treadles, with separate returning-cords, reversely connecting the treadles and clutches.

In the annexed drawings, Figure 1 represents a side elevation, partly in section, of a treadle or manual power machine embodying my improvements. Fig. 2 is a front elevation thereof, and Figs. 3 and 4 represent side and

edge views of the improved clutch removed and on a larger scale.

In the drawings, *a a* represent the frame of the machine, which may be formed in any suitable design, the top preferably forming a table. *b* is the shaft of the machine, hung in centers or suitable bearings in the frame, and carrying a heavy fly-wheel, *c*, the rim of which may be grooved for the reception of belts, by which the power generated may be transmitted in the required direction. *g g* are the treadles, which may be of any suitable form, pivoted to the frame in a suitable manner, and connecting with the clutches, as represented. *A A* are the pulley-wheels, on which the clutches connecting with the treadles operate to revolve the shaft. *B* are radial arms, which carry the clutches. These arms are hung loosely on the shaft *b*, and lie closely to the wheels *A*, being held in position by collars *f f*, Figs. 2 and 4, fixed to the shaft. The wheels *A* are keyed to and revolve with the shaft, and are formed with a series of varying diameters, *d e*, to one of which a clutching or brake shoe, *C*, carried by the arm *B*, is nicely fitted. One end of the shoe is inclined, to act as a wedge against a wedging-stop, *D*, formed on the arm *B*, as shown more fully in Figs. 1 and 3, while the other end of the shoe receives the contact of a cramping-lever, *F*, also carried on and pivoted to the arm *B*.

E is a flexible cord, chain, or band, which is connected with the end of the lever *F*, passes over one of the diameters of the wheel *A*, and connects with the treadle, as shown more clearly in Fig. 1. This forms a very powerful friction ratchet or clutch, which is noiseless and practically positive, and operates as follows: When the strain of the treadle is applied to the cord *E*, it is transmitted through the lever *F* to the clutch-shoe *C*, which instantly becomes wedged in against the rim of the wheel *A* so powerfully that wheel and clutch become integral, and the wheel and shaft revolve during the full period the strain is applied. When the strain is removed the parts of the clutch become instantly relaxed, and the arm *B*, with its connections, falls back to its original position, without in the least affecting the wheel or shaft, which continues

to rotate by the momentum acquired through the impulse of power imparted by the previous gripe of the clutch. These impulses or strokes of the treadle and clutch may be repeated at short or long intervals, at the will of the operator and the requirements of the work, as it will be observed that the construction is such that the treadle and clutch may be at rest while the shaft continues to revolve. To vary the speed and power, the cord E of the clutch may be passed over a different diameter of the wheel A, or over the hub of the clutch-arm B, which forms a continuation of the varying diameters, as seen more fully in Fig. 3, the treadle being provided with a separate point of connection for each diameter of the wheel, as seen in Fig. 1.

The wedging-stop D is preferably pivoted to the arm B, as represented, to act more harmoniously with the wedging-shoe C, and adapt itself to its movement without injuring the wedging effect. The lever F bears upon the shoe C, preferably by means of a cam-spur, *i*, formed thereon, and the pivoted end of the lever is provided with a small projection, *k*, which engages with a similar projection on the wedging-stop D, which prevents the lever moving out of position, and thus also serves to hold the shoe C in place.

The machine may be made single-acting, if desired for light purposes, with but one treadle and clutch, a spring being used to return the treadle; but for the chief objects of my invention I construct the machine double-acting, with two alternating treadles and clutches, by which a continuous action may be secured, the treadles, as represented in the drawing, being of large and strong construction, designed to receive the full weight of the operator in a standing position thereon, and which is applied to the rotation of the shaft by an easy and natural stepping motion, transferring the weight alternately from one treadle to the other.

To effect the alternate movement of the treadles and clutches in a positive manner, and without loss of power from the employment of returning springs or weights, I connect the two treadles together by a reciprocating chain or cord, H, the opposite ends of which are secured to the treadles, and the loop of which is supported on a freely-turning pulley, G, hung from the top of the frame, as shown in Figs. 1 and 2; and to insure the positive return movement of the clutches, returning cords or chains I are secured to the hub of the clutch-arm B, on the under or reverse side, the said chains winding under the hub, and connecting with the reciprocating cord H of the treadles.

By this arrangement it will be observed that the treadles and clutches become mutually balanced and connected, so that the full weight of the operator, when exerted equally on both treadles, will be sustained thereon in a position of rest at any position of the treadles

without affecting the shaft, which may continue to rotate, and by throwing the weight on one treadle the power is exerted to continue the rotation of the shaft, while the other treadle and clutch becomes relaxed and returned in a positive manner and without friction, thus obviating the use of springs or weights.

By this construction the operator may take short or long steps on the treadle, making a full stroke or any fractional part of a stroke at either short or long intervals, with long or short intervals of rest intervening between the intervals of action, the movements being thus entirely at the will of the operator and controlled by the requirements of the work, the impulses of power being imparted only as required, and intervals of rest taken during the periods when the momentum of the machine is sufficient to continue its effective rotation. By this means dead-points are obviated, a positive, uniform, and continuous rotation of the fly-wheel is secured, and the greatest possible power of the operator is obtained with the least exertion and fatigue.

This mutually-connected arrangement of the treadles and clutches is not, of course, confined to use in connection with the special form of friction clutch or ratchet described. Nor is this particular form of clutch or ratchet necessary to the clutch or ratchet wheel A of varying diameters, as will be understood; but this form of clutch is found best adapted for the purpose.

Any equivalent mutually connecting device may be used in lieu of that shown without departing from the principle of my invention. For instance, connecting-rods and walking-beam may substitute the chain H and pulley G; and instead of the returning-cords I being attached to the reciprocating cord H, they may be attached, with the same effect, directly to the treadles, the cord of one clutch being attached to the treadle of the other clutch; but the arrangement shown is thought preferable.

My invention is applicable to treadles for circular and scroll saws, lathes, sewing-machines, velocipedes, &c.

What I claim as my invention is—

1. In a treadle-power, the combination, with double alternating treadles and friction-clutches, of an independent and positively-reciprocating treadle cord or chain, H, and separate clutch-returning cords E, substantially as herein shown and described.

2. In a treadle or manual power, an intermittingly-acting friction-clutch, connecting the treadle with the fly-wheel shaft, and formed of the combination, with a pulley, A, revolving with the shaft, of a radial arm, B, hung loosely on the shaft and carrying a wedging-shoe, C, which is fitted to the rim of the wheel, bears against a wedging-stop, D, and receives the pressure of a lever, F, also carried by the arm B, the end of which connects with the

treadle, substantially as herein shown and described.

3. In a treadle or manual power, in combination with an intermittent clutch or ratchet, connecting with the treadle by means of a flexible cord, or equivalent, the pulley *A d e*, formed with a series of varying diameters, *d*

e, over either of which the clutch-cord may be passed, substantially as and for the purpose set forth.

WILLIAM LEVIN.

Witnesses:

CHAS. M. HIGGINS,
EDWARD H. WALES.