

R. R. MILLER.  
Running-Gear for Carriages.

No. 207,761.

Patented Sept. 3, 1878.

Fig. 1.

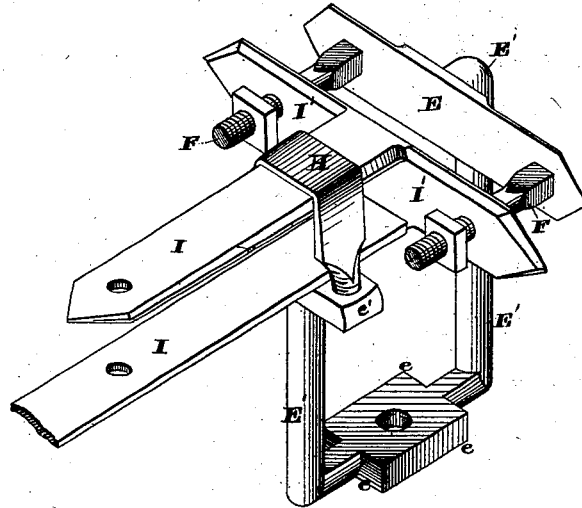
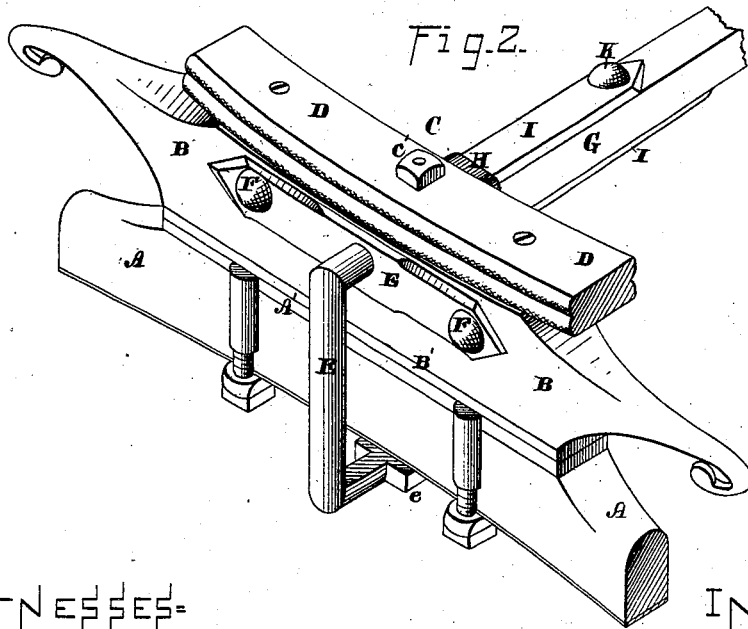

Fig. 2.



WITNESSES=

*Jack Hutchinon.*  
*Henry B. Hazard.*

INVENTOR.

*Robt. R. Miller, by*  
*Orindle & Co. his attys*

R. R. MILLER.  
Running-Gear for Carriages.

No. 207,761.

Patented Sept. 3, 1878.

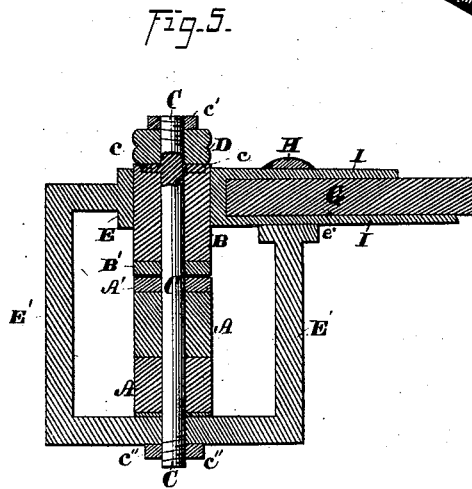
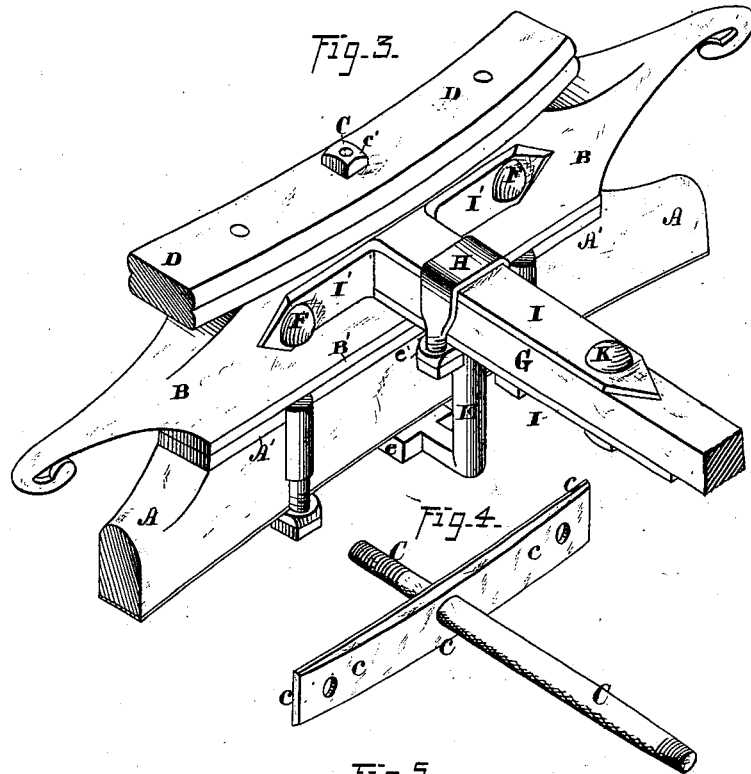

WITNESSES:

Geo. W. Hutchinson,  
Henry B. Hazard.

INVENTOR.

Robt. R. Miller, by  
Purdell & Co. his Attys.

# UNITED STATES PATENT OFFICE.

ROBERT R. MILLER, OF PLANTSVILLE, CONNECTICUT.

## IMPROVEMENT IN RUNNING-GEARS FOR CARRIAGES.

Specification forming part of Letters Patent No. 207,761, dated September 3, 1878; application filed May 1, 1878.

*To all whom it may concern:*

Be it known that I, ROBERT R. MILLER, of Plantsville, in the county of Hartford, and in the State of Connecticut, have invented certain new and useful Improvements in Running-Gears for Carriages; and do hereby declare that the following is a full, clear, and exact description thereof, reference being had to the accompanying drawings, making a part of this specification, in which—

Figure 1 is a perspective view of the parts of my improvement separated from the other portions of the running-gear, but having their proper relative arrangement. Fig. 2 is a like view of the same from the front when combined with the axle, head-block, spring, and reach. Fig. 3 is a perspective view of the same from the rear. Fig. 4 is a like view of the king-bolt separated from the other portion of the running-gear; and Fig. 5 is a vertical central section upon a line extending from front to rear.

Letters of like name and kind refer to like parts in each of the figures.

The design of my invention is to simplify, strengthen, and render more durable the connection between the front axle, head-block, reach, and spring; and to this end it consists, principally, in the construction of the yoke and its combination with the head-block, reach, and king-bolt, substantially as and for the purpose hereinafter specified.

It consists, further, in the construction of the reach-iron and its combination with the head-block and reach, substantially as and for the purpose hereinafter shown.

It consists, further, in the form of the king-bolt and its combination with the axle, head-block, and spring, substantially as and for the purpose hereinafter set forth.

It consists, finally, in the combination of the yoke, reach-iron, and king-bolt with each other, the axle, reach, head-block, and spring, substantially as and for the purpose hereinafter shown and described.

In the annexed drawings, A represents an axle, and B a head-block, of usual construction, the contiguous faces of which are faced with metal plates A' and B', respectively, as shown. The head-block B is pivoted upon the axle A

by means of a king-bolt, C, which extends vertically through the same and has the usual form, except that at the upper face of said head-block said king-bolt is provided with a flange, c, that extends outward along or within said face, and is curved to correspond to and receive an elliptic spring, D. From said head-block said bolt C extends upward through said spring, and above the latter is threaded and provided with a nut, c', which fits upon said end and operates to confine said parts firmly together. Secured to or upon the front side of the head-block B is a plate, E, that extends lengthwise of said block, and is held in place by means of two bolts, F, one of which passes horizontally through each end of said plate and through said block. From the center of the plate E a bar, E', extends horizontally forward, thence downward to the bottom of the axle A, thence rearward beneath the same, and thence upward to a reach, G, at which point is provided a horizontal laterally-extending plate, e', that projects beyond each side of said reach and receives a strap, H, which operates to bind said parts together. Where the bar or yoke E' passes beneath the axle A, a lateral enlargement, e, is formed and through the same projects the lower threaded end of the king-bolt C, the nut c'' upon the latter being below said yoke, and said bolt operating as a pivotal bearing for and upon which said yoke turns.

It will be seen that the office of the yoke E' is to strengthen the pivotal connection between the axle A and head-block B, and that from its construction and operation said yoke has the same function as an ordinary fifth-wheel, but is materially stronger and possesses greater lateral rigidity than the latter.

The reach G is connected to or with the head-block B by means of a strap, I, which embraces the upper and lower sides and front end of said reach, and is held in place upon the latter by means of the strap H and one or more bolts, K, that pass vertically through said reach and said strap I, near the rear ends of the latter. At the front end of the strap I is provided a flange, I', which extends laterally outward in opposite directions along the rear face of the head-block B and receives the rear ends of the bolts L, that pass through the plate

E of the yoke E', said flange operating to firmly unite said head-block and the reach G.

The connections of the reach, head-block, spring, and axle are now complete, and, while strong and durable, are much less expensive than those usually employed.

Having thus fully set forth the nature and merits of my invention, what I claim as new is—

1. As a means for connecting the axle A, head-block B, and reach G, the yoke E', provided at its front upper end with the laterally-extended plate E, bolted to the head-block at two points, and at its lower central portion with the lateral enlargement e, and at its rear end with the plate e', and combined with said parts in the manner substantially as specified.

2. As a means for connecting together the head-block B and reach G, the reach-iron I, arranged to embrace the upper and lower sides of said reach, and provided at its front end with a flange, I', which bears against and is secured to said head-block, said parts being

combined in the manner and for the purpose substantially as shown.

3. The king-bolt C, provided near its upper end with a laterally-projecting flange, c, forming a spring-bed, above which is a threaded portion that passes through the spring D and receives a nut, c', and having its lower threaded end, which projects below the axle A, provided with a nut, c'', substantially as and for the purpose set forth.

4. The king-bolt C, provided with the flange c and nuts c' and c'', the yoke E E', constructed as shown, and the reach-iron I I', having the form described, in combination with each other, the axle A, the head-block B, the spring D, and the reach G, substantially as and for the purpose specified.

In testimony that I claim the foregoing I have hereunto set my hand.

ROBERT R. MILLER.

Witnesses:

MARY J. LEWIS,  
A. M. LEWIS.