

W. MENKHOFF.
Straw-Braid Sewing-Machine.

No. 207,763.

Patented Sept. 3, 1878.

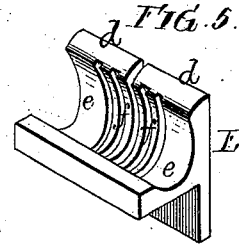
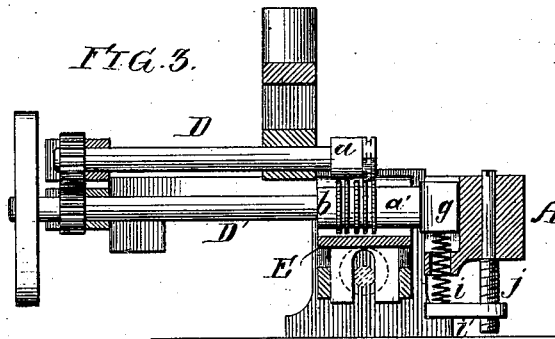
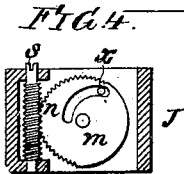
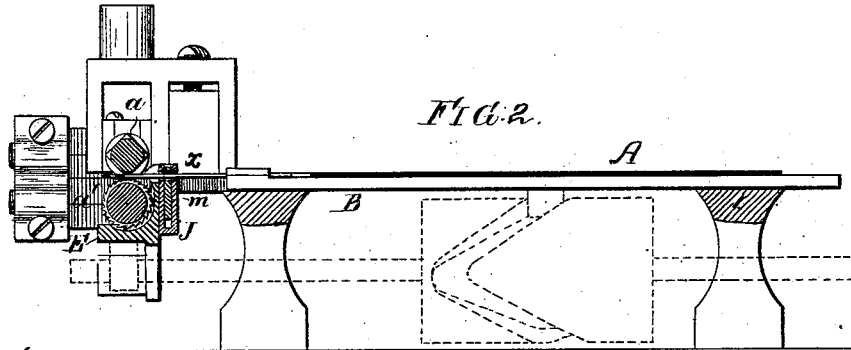
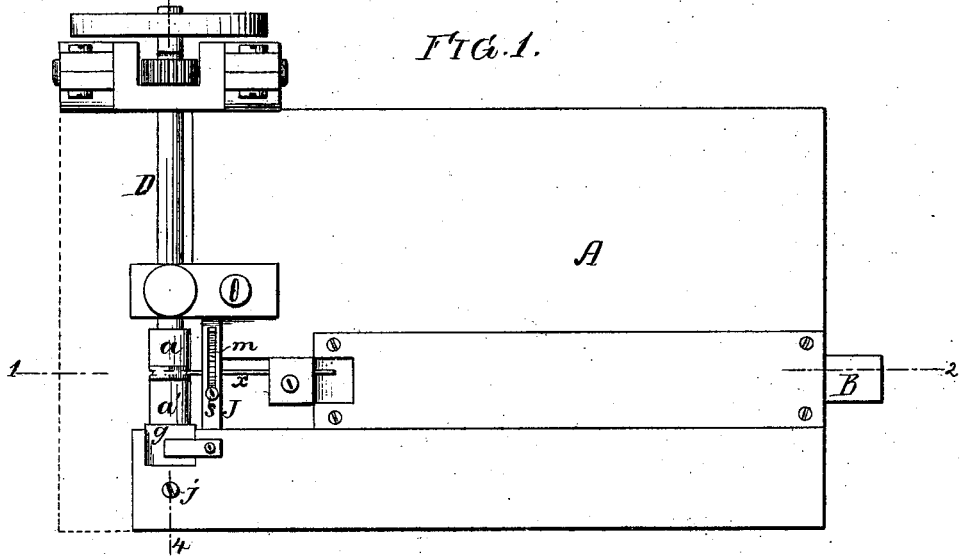

Witnesses,
M. Decker
Henry Smith

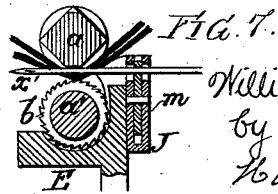
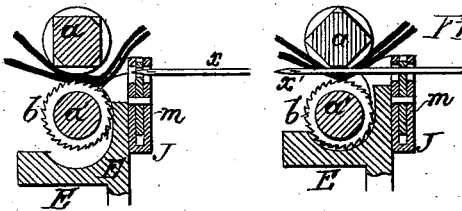

Inventor:
William Menkhoff
by his Attorneys
Howson & Co.

UNITED STATES PATENT OFFICE.

WILLIAM MENKHOFF, OF PHILADELPHIA, PENNSYLVANIA, ASSIGNOR TO
HENRY FRIEDBERGER, OF SAME PLACE.

IMPROVEMENT IN STRAW-BRAID-SEWING MACHINES.

Specification forming part of Letters Patent No. 207,763, dated September 3, 1878; application filed
July 15, 1878.

To all whom it may concern:

Be it known that I, WILLIAM MENKHOFF, of Philadelphia, Pennsylvania, have invented a new and useful Improvement in Straw-Braid-Sewing Machines, of which the following is a specification:

My invention relates to certain improvements in the straw-braid-sewing machine for which Letters Patent No. 200,022 were granted to the assignees of Frederick Blackburn and Valentine Moeslein on the 5th day of February, 1878, the main object of my invention being to improve the construction and operation of the feeding and needle-guiding devices of the machine.

This object I attain in the manner which I will now proceed to describe, reference being had to the accompanying drawing, in which—

Figure 1 is a plan view of a sufficient portion of a straw-braid-sewing machine to illustrate my improvement; Fig. 2, a longitudinal vertical section of the same on the line 1 2; Fig. 3, a transverse vertical section on the line 3 4; Figs. 4 and 5, detached views of parts of the machine; and Figs. 6 and 7, diagrams illustrating the mode of sewing.

A is the flat bed or table of the machine, and B the needle-bar, which is reciprocated by means of a slotted cam on a shaft beneath the table. (See dotted lines, Fig. 2.)

In a working machine the table A is extended, as shown by dotted lines in Fig. 1, so as to inclose a shuttle-race; but as this portion of the machine has nothing to do with my invention, it has not been deemed necessary to illustrate or describe it.

D D' are two shafts extending transversely across the front end of the machine, each of these shafts being adapted to a pivoted bearing at the rear end, so that it can vibrate independently of the other shaft, the shafts being geared together by suitable cog-wheels, so that they turn in reverse directions.

The upper shaft, D, carries at the front end a feed-roll, *a*, with an angular extension similar to that described in the aforesaid Patent No. 200,022; but the feed-roll *a'* at the front end of the lower shaft, D', instead of being constructed in a manner similar to the roll *a*, has a series of toothed rings, *b*, so arranged that they will act on the braid on both sides

of the needle *x*. These rings may be cast or otherwise formed directly on the feed-roll *a'*; but I prefer to reduce said roll in diameter, and then secure to the said reduced portion any desired number of toothed rings, the distance between adjacent rings being determined by intervening washers, which are less in diameter than the rings.

E is the crimping-plate for bending the strips of braid around the upper feed-roller prior to the passage of the needle. This crimping-plate is reciprocated vertically by means of a cam on the main shaft, as shown by dotted lines, Figs. 2 and 3; and has a rounded top, *d*, and a curved inner surface, *e*, in which are formed a number of grooves, *f*, corresponding in number and position with the toothed rings *b* on the feed-roll *a'*, so that when the crimping-plate is depressed it will fit closely to the said lower feed-roll, for a purpose explained hereinafter. The upper edge of the crimping-plate is slotted in the center for the passage of the needle *x*, and the corners of the angular extension of the upper feed-roll are likewise slotted for a similar purpose.

The outer end of the lower feed-shaft, D', has its bearing in a spring-box, *g*, so that the lower feed-roll can yield vertically to accommodate itself to braid of different thicknesses, as in the former Patent No. 200,022. The spring *i* bears upon an arm, *v*, having a threaded opening adapted to a threaded stem, *j*, the upper portion of which extends through the bed of the machine, so as to be operated from above the same.

Adjacent to the crimping-plate E is a box or frame, J, within which is pivoted a disk, *m*, Fig. 4, having formed in it a cam-slot, *n*, and having a toothed periphery, adapted to the thread of a vertically-fixed screw-stem, *s*, upon turning which the disk *m* will be rotated.

The cam-slot *n* receives the stem of the needle *x*, so that by rotating the disk *m* in one direction or the other the point of the needle is thrown up or down, thereby governing the point at which the needle passes through the crimped braids, and consequently regulating the extent to which the stitch is exposed on the face of the braid.

I am aware that vertically-adjustable plates

have heretofore been used for this purpose; but the advantage of the disk with its cam-slot is that a new wearing-surface is always brought into play upon each new adjustment of the disk, so that the latter will remain in operative condition for a much longer time than a vertically-adjustable plate having a single circular opening, upon which the wear is constant. The sides of the box J have vertical slots, which permit the desired deflection of the end of the needle.

A horizontally-sliding plate, having a cam-slot, *n*, may be substituted for the pivoted disk *m*, if desired; but the latter is preferred on account of its compactness and readiness of operation.

The action of the machine is shown in Figs. 6 and 7.

When the layers of braid are being moved forward by the feed-rolls the needle is retracted and the crimping-plate E is depressed, as shown in Fig. 6, so that it fits closely to the lower feed-roll, and prevents the braid from being carried around by the same, the rounded top of said plate E serving to deflect the braid upward.

When the feeding motion is completed, the crimping-plate E rises, so as to bend the braid around the angular extension of the upper feed-roll, *a*, the needle then moving forward through the crimped braid, so as to form the stitch. (See Fig. 7.)

When the needle has been retracted the crimping-plate descends, and the braid is then fed forward, as before, prior to a repetition of the operation.

It will be evident that the toothed rings, acting on the braids on both sides of the needle, form a much more regular and effective feeding device than simple roughened rollers acting on the braid on one side of the needle only, as in the patented machine above alluded to.

I claim as my invention—

1. The combination of the feed-roll *a'*, having toothed rings, as described, with the grooved crimping-plate E, adapted to said roll, all substantially as set forth.

2. The combination of the feeding devices, the needle, and an adjustable disk or plate, *m*, having a cam-slot, *n*, as specified.

3. The combination of the feeding devices, the needle, the pivoted disk *m*, having a cam-slot, *n*, and toothed periphery, and the operating-screw *s*, as set forth.

In testimony whereof I have signed my name to this specification in the presence of two subscribing witnesses.

WILLIAM MENKHOFF.

Witnesses:

HARRY A. CRAWFORD,
HARRY SMITH.