

J. WATSON. Pump-Valves.

No. 207,784.

Patented Sept. 3, 1878.

Fig. 2.

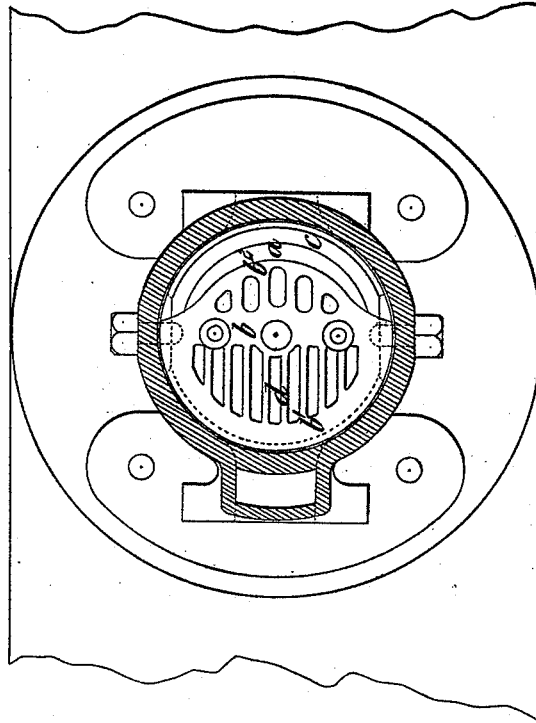
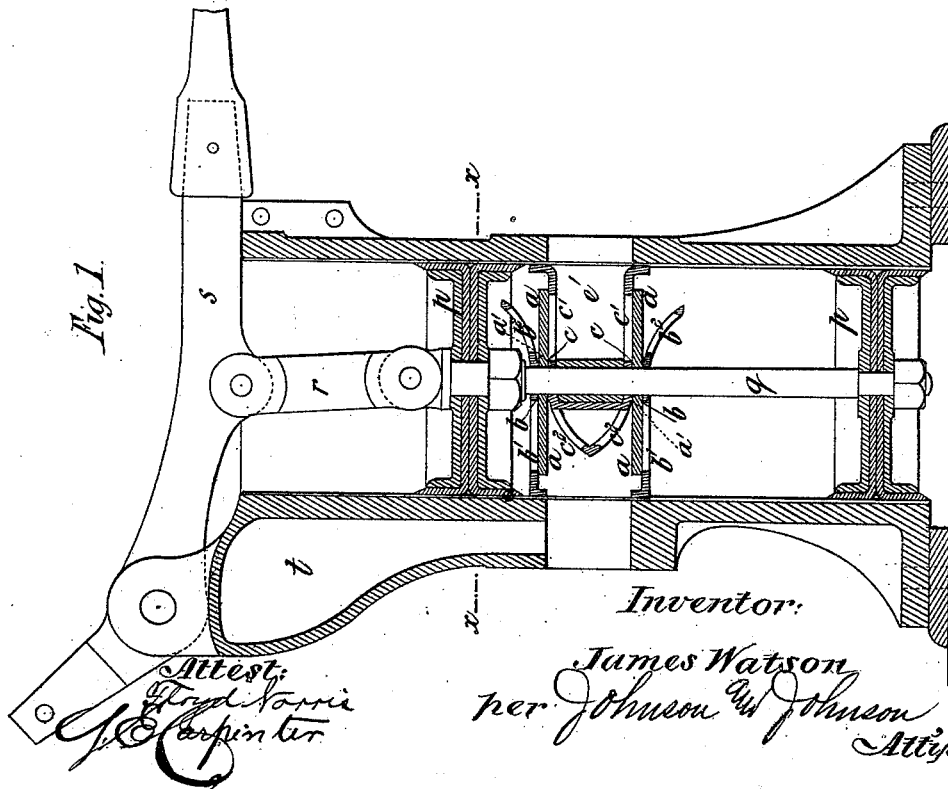

Fig. 1.



Inventor:

*James Watson
per Johnson & Johnson
Attys.*

*Attest:
Fred Harris
Carpenter*

J. WATSON. Pump-Valves.

No. 207,784.

Patented Sept. 3, 1878.

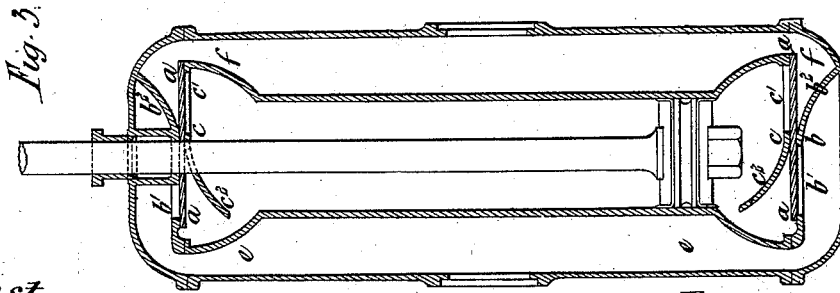
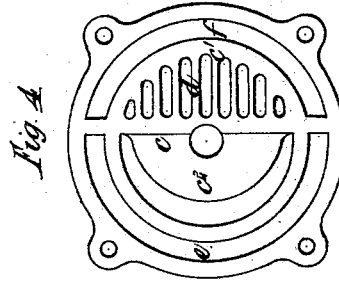
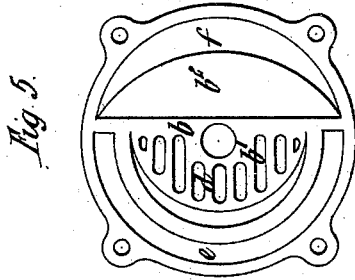
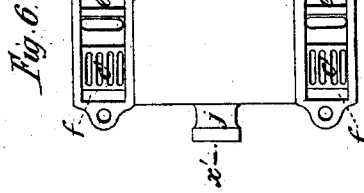
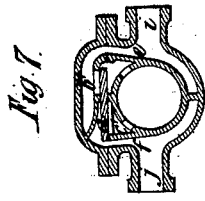

Attest

Floyd Norris
J. Carpenter

Inventor:

James Watson
per Johnson & Johnson
Attys

J. WATSON.
Pump-Valves.

No. 207,784.

Patented Sept. 3, 1878.

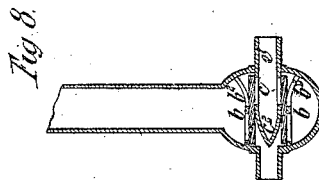
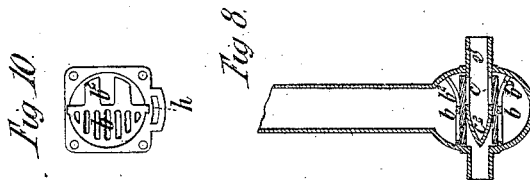
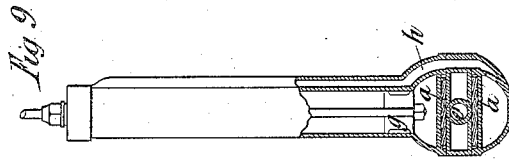
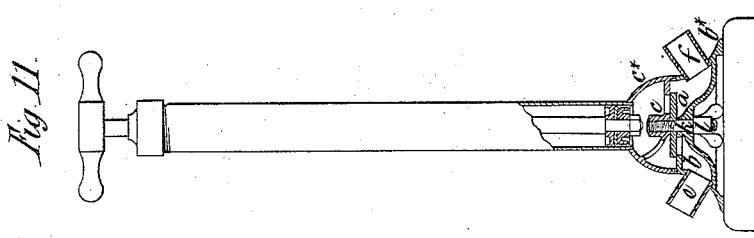
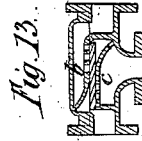
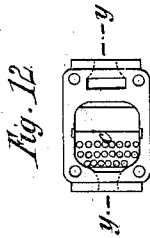

Attest:

Floyd Harris
J. Carpenter

Inventor:

James Watson
per Johnson & Johnson
Attys

UNITED STATES PATENT OFFICE.

JAMES WATSON, OF GREENWICH, ENGLAND.

IMPROVEMENT IN PUMP-VALVES.

Specification forming part of Letters Patent No. **207,784**, dated September 3, 1878; application filed July 6, 1878; patented in England, November 13, 1876.

To all whom it may concern:

Be it known that I, JAMES WATSON, of Greenwich, England, engineer, have invented new and useful Improvements in Pumps, for which English Letters Patent were granted to me under date November 13, 1876, of which the following is a specification, reference being had to the accompanying drawings.

This invention relates to pumps provided with valves of india-rubber or other similar flexible material—such as leather or india-rubber and canvas combined, or the like—and is chiefly designed to cheapen and simplify the construction of these valves.

The said invention is applicable to pumps for steam or hand fire-engines, pumps for locomotive, marine, or stationary engines, to garden-pumps, and other pumps, and in which ordinary india-rubber or other flexible valves are or may be used.

The said invention consists, chiefly, in so constructing the valves, valve-seats, and passages that one valve controls both the suction and the delivery of the pump, the said valves, valve-seats, and passages being combined with the other parts of the pump, and adapted to pumps with either fixed or oscillating cylinders or barrels, as hereinafter described. The said valves are applicable to either single or double acting pumps. In single-acting pumps they may be arranged at either end of the barrel in the usual manner, and in double-acting pumps they may be arranged at one or both ends or in the center of the pump-barrel.

By my invention I obtain the advantage of having the valves arranged close to the barrel of the pump, thereby diminishing the air-space and affording great facility for examination of the said valves. Moreover, the simplicity of construction of the said valves will considerably reduce the cost of the manufacture of pumps.

In the accompanying drawings I have shown how I carry my invention into practice with various forms of pumps.

Figure 1 is a longitudinal central section of a double-acting pump with a fixed barrel provided with valves according to my invention. Fig. 2 is a transverse section through the said pump-barrel on the line *x x*, showing the top of the valves. Fig. 3 is a longitudinal section

of another double-acting pump with a fixed barrel and provided with valves according to my invention. Fig. 4 is an end view of the same with the cover removed. Fig. 5 shows the inner side of the said cover. Fig. 6 is an elevation of a double-acting oscillating pump with trunnions at the center of its cylinder or barrel, and provided with valves according to the said invention. Fig. 7 is a transverse section of the same on the line *x' x'*. Figs. 8 and 9 are longitudinal sections of a double-acting pump provided with valves according to my invention at one end of the same. Fig. 10 is an under-side view of one of the valve-seats of this pump. Fig. 11 is an elevation, partly in section, of a single-acting pump, suitable for a garden-pump or the like, and provided with valves according to my invention at its lower end. Fig. 12 is a plan or top view of a valve-box for a single-acting pump constructed according to my invention with the cover of the same removed. Fig. 13 is a vertical section of the same on the line *y y*.

Like letters indicate the same parts throughout the drawings.

In forming the valves shown in Figs. 1, 2, 3, 4, and 5, I take sheets of india-rubber of the kind ordinarily used for forming valves and for similar purposes, or any other suitable material—such as leather, india-rubber, and canvas, or the like—of the necessary dimensions and thickness. I fit these india-rubber or other sheets which form the valves *a* between two faces, *b c*, properly shaped to insure the close fitting of the valve thereon, and with sufficient space between them to allow the said valves to have the required movement between the said faces. Each of the said valves is held at its central portion, *a'*, securely between the two faces *b c*, which are so formed and arranged that there is only sufficient space between them at this central portion to allow the valve to be fitted therein; but the face *b* is curved or sloped away from this central portion on one side of the said valve, and the other face, *c*, is oppositely curved or sloped outward from the shaft on the other side of the valve, as shown.

Through the flat portions *b' c'*, which are the valve-seats, I form apertures or ports for the passage of the water, while the curved or

sloping portions $b^2 c^2$ serve as stops or guards for said valves. The said seats are preferably grated, as shown at d , Fig. 2, or they may be perforated with small holes. When the valve is open or raised from the said seats the water passes freely through them; but they are closed when the valve is down upon or in contact with its seats.

In Fig. 1 there are two valves, a , with an inlet-chamber, e' , between them, and I have shown the pump provided with two pistons, p , at the ends of the rod q , which, at its upper end, is connected by a link, r , with the double lever or handle s , whereby the pump is operated. t is a space used as an air-vessel.

In Fig. 3 the perforated or grated seat b^1 is in the suction or inlet passage or aperture e , and the other seat, c^1 , is in the delivery or discharge aperture or passage f . The valve a extends to and covers both of these seats. It will thus be seen that I make one valve serve both as a suction and delivery valve.

In Figs. 8, 9, and 10 I have shown two valves, a , with an inlet-chamber, e' , between them. One of these valves admits and discharges the water on one side of the piston or plunger g , and the other valve admits and discharges the water on the other side of the said plunger. h is the passage by which the water passes to and from the upper or forward end of the pump.

In pumps in which the valves are subjected to a very high pressure I prefer to place springs at the back of the said valves to strengthen the valves and assist in closing the same.

In adapting the said invention to oscillating pumps I may construct the same with trunnions either at the end or at the center of the barrel. One trunnion connects with the suction pipe or passage, and the other with the delivery or discharge pipe of the pump.

In Figs. 6 and 7 I have shown a pump with trunnions i, j at the center of the barrel. The trunnion i is connected with the suction-pipe, and the suction or inlet passage e extends therefrom to the seat b^1 , and through the same into the barrel. The outlet or delivery pas-

sage f is through the seat c^1 , and thence extends to and through the trunnion j , as shown in Fig. 7. Suitable longitudinal passages are cast at the sides of the barrel to connect the trunnions with the valves at both ends of the said barrel.

The pump shown in Fig. 11 is portable, and will be found very convenient for garden use. Its valve a is secured between the two faces b, c , which, in this case, are cast or fixed in the upper and lower portions, $b^* c^*$, of the valve-box. These two portions are secured together by the central screw and nut k, l . The inlet-passage e and outlet-passage f are conveniently formed for the attachment of india-rubber or other flexible pipes.

The valve and seats shown in Figs. 12 and 13 are substantially the same as those shown in Figs. 1, 2, 3, 4, 5.

In applying my said invention to a fire-engine I prefer to have two double-action oscillating pumps arranged opposite each other, and working on one central crank or lever. The suction and discharge pipes are to be connected with the said trunnions and with suitable air-vessels. I inclose the barrels in suitable jackets or casings, and, if desired, I may make the space inclosed between the said jackets and the barrels serve as air-vessels; or I may use air-vessels of the usual construction.

What I claim is—

1. In a pump provided with a valve or valves, of india-rubber, leather, or other like material, the valve or valves a and valve-seats b, c, b^1, c^1 , so constructed and fitted together and in combination with the suction and delivery passages that one valve will control both the suction and the delivery of the said pump, substantially as above set forth.

2. The combination of the two valves a and plates or faces b, c with the inlet-chamber e' between them, substantially as and for the purpose specified.

JAMES WATSON.

Witnesses:

WM. ROBT. LAKE,
JOHN T. KNOWLES.