

R. VEREA.
Calculating-Machine.

No. 207 918.

Patented Sept. 10, 1878.

Fig. 1

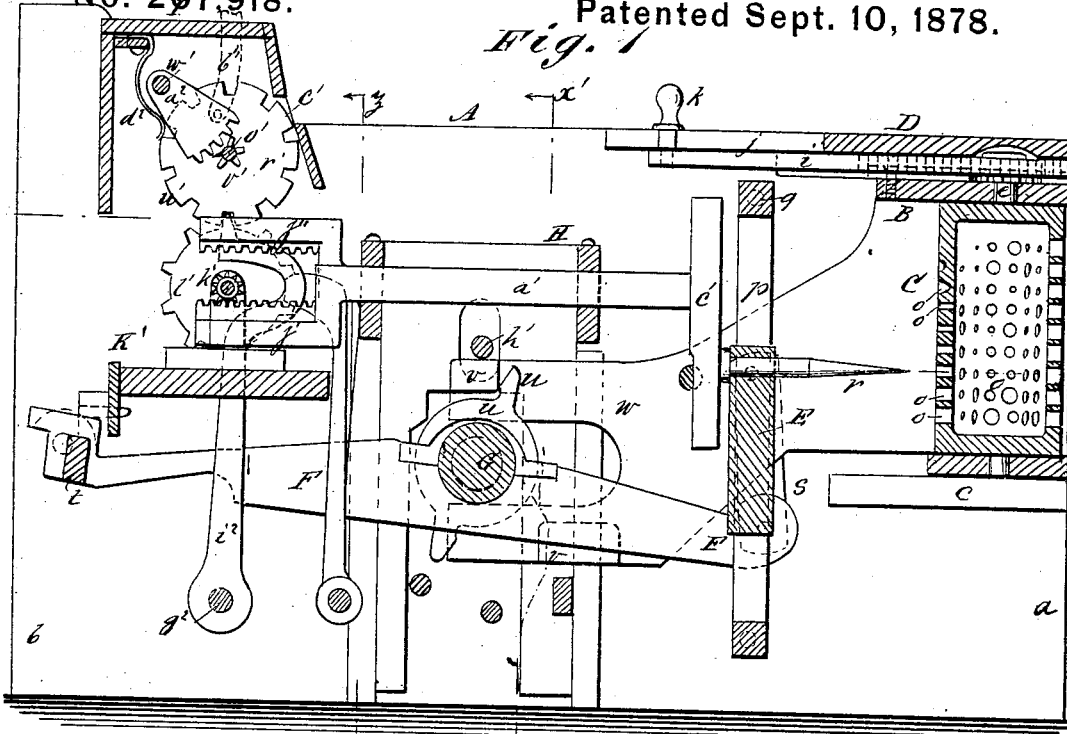
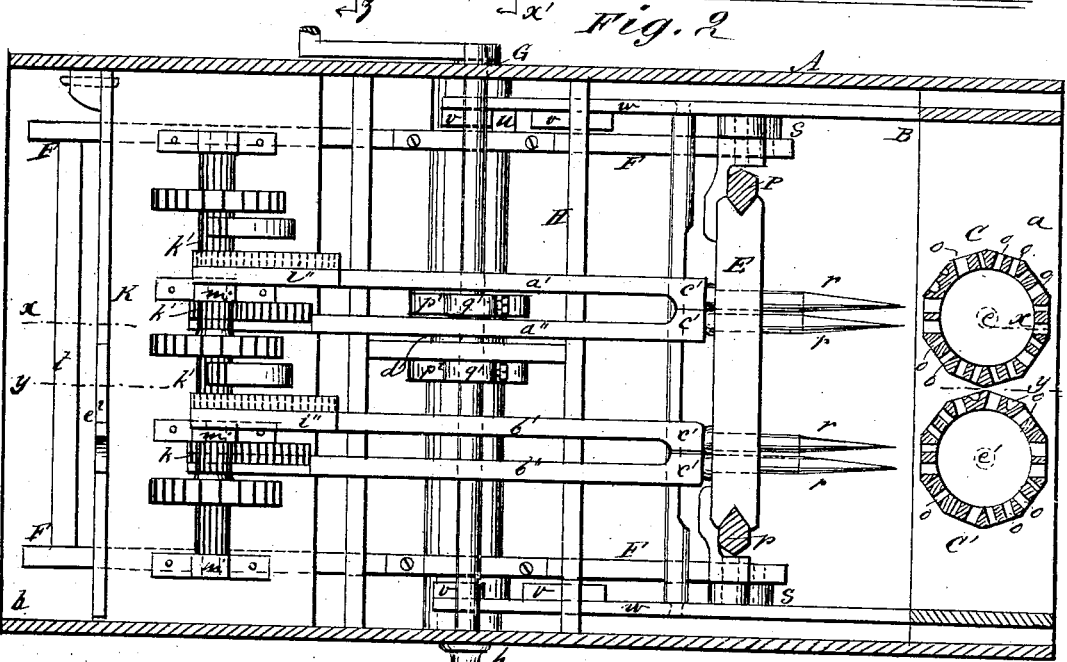

Fig. 2



WITNESSES:

C. Verrea
A. Sedgwick

INVENTOR:

R. Verrea

BY *Munn & Co.*

ATTORNEYS.

R. VEEA.
Calculating-Machine.

No. 207,918.

Patented Sept. 10, 1878.

Fig. 5.

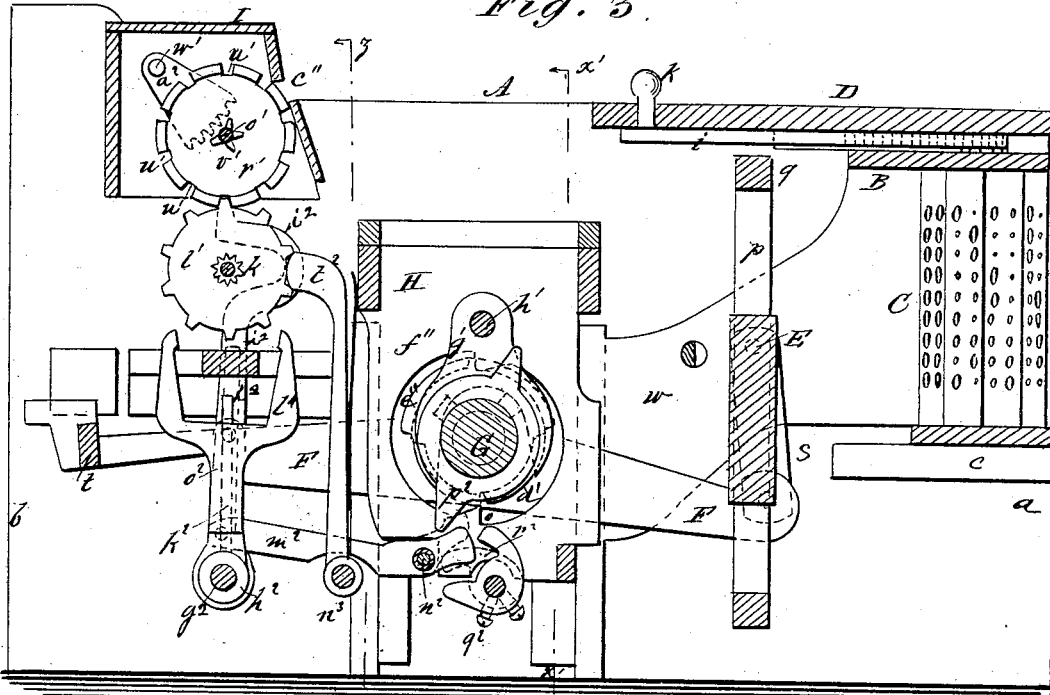
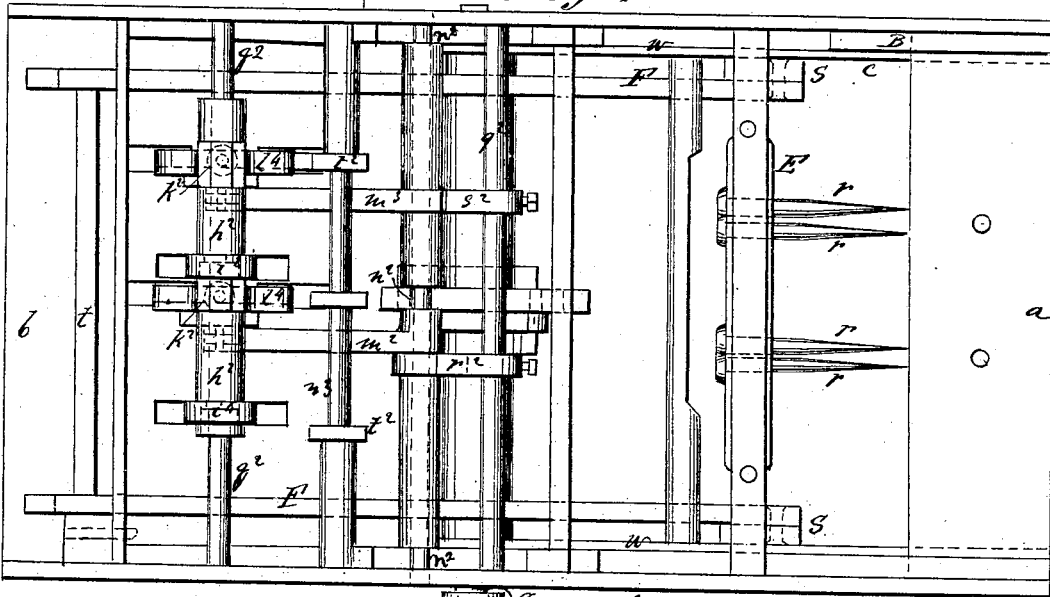

Fig. 4.



WITNESSES:

C. Newell
C. Sedgwick

INVENTOR:

R. Verea
BY *Munn & Co*

ATTORNEYS.

R. VEREA. Calculating-Machine.

No. 207,918. *Fig. 5* Patented Sept. 10, 1878.

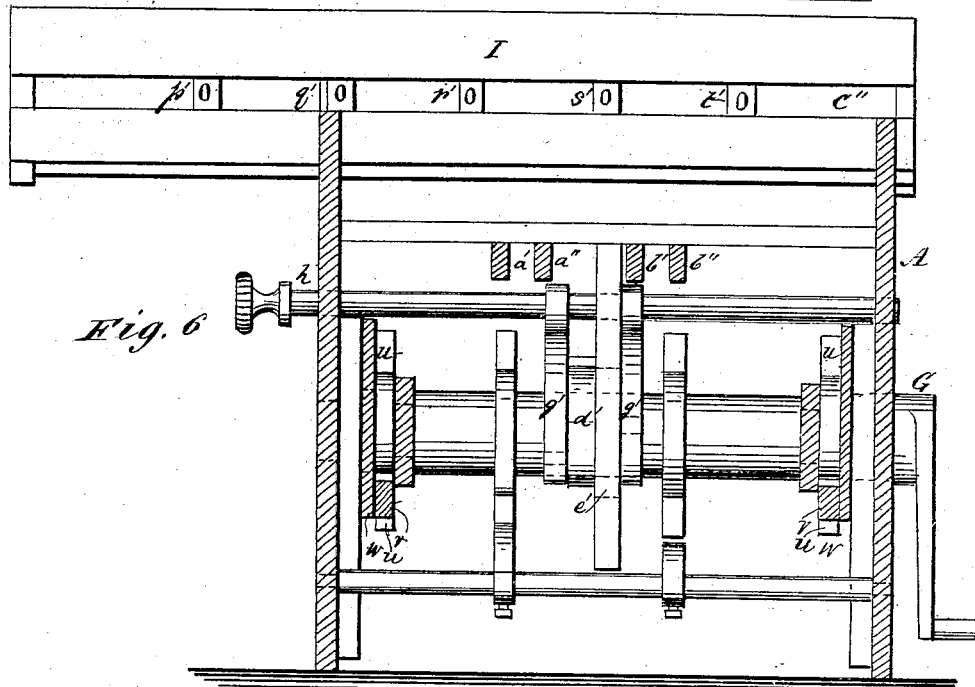
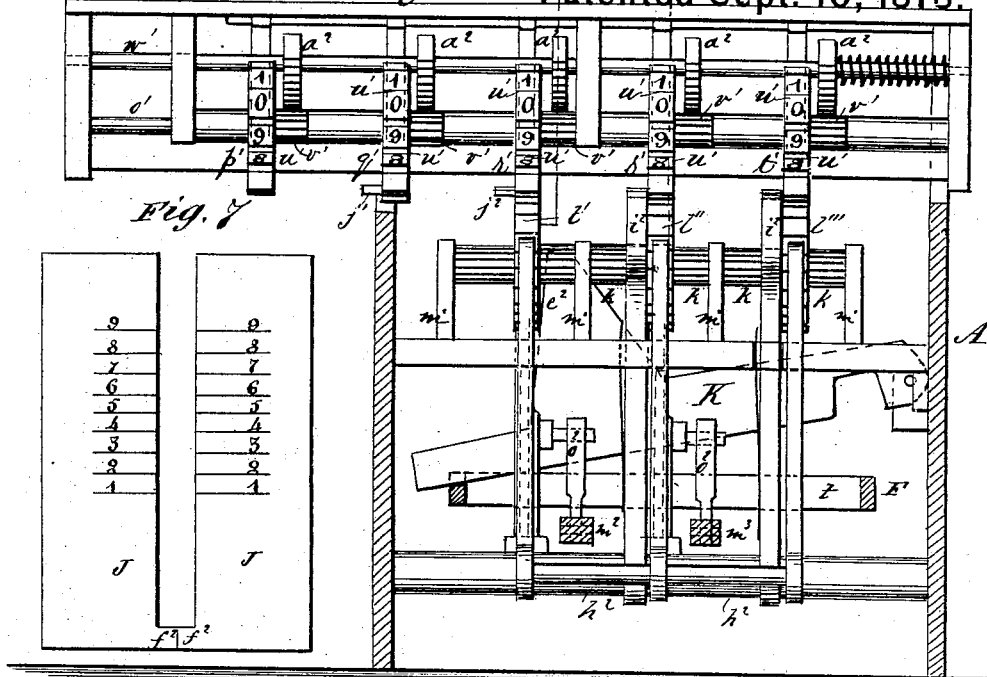

WITNESSES:
C. Vereux
G. Sedgwick

INVENTOR:
R. Vereux
 BY *Munn & Co*
 ATTORNEYS.

R. VERA.
Calculating-Machine.

No. 207,918.

Patented Sept. 10, 1878.

Fig. 8

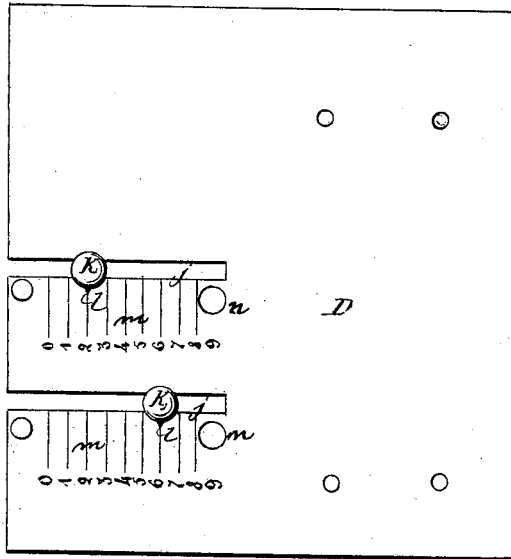

Fig. 9

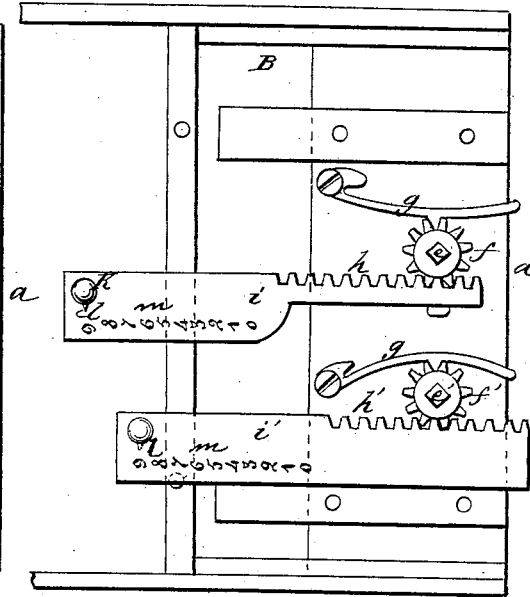

Fig. 10

9	8	7	6	5	4	3	2	1	0	
81	72	63	54	45	36	27	18	09	99	9
72	53	34	15	95	76	57	38	19	99	8
63	34	05	75	46	17	87	58	99	99	7
54	15	75	36	96	57	18	78	39	99	6
45	96	46	96	47	97	48	98	49	99	5
36	76	17	57	97	38	78	19	59	99	4
27	57	87	18	48	78	09	39	69	99	3
18	38	58	78	98	19	39	59	79	99	2
09	19	29	39	49	59	69	79	89	99	1

WITNESSES:

C. Veroux
C. Sedgwick

INVENTOR:

R. Vera
BY *Mum* *Co*

ATTORNEYS.

R. VEEA.
Calculating-Machine.

No. 207,918.

Patented Sept. 10, 1878.

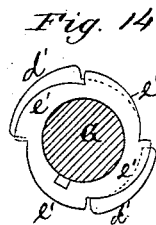
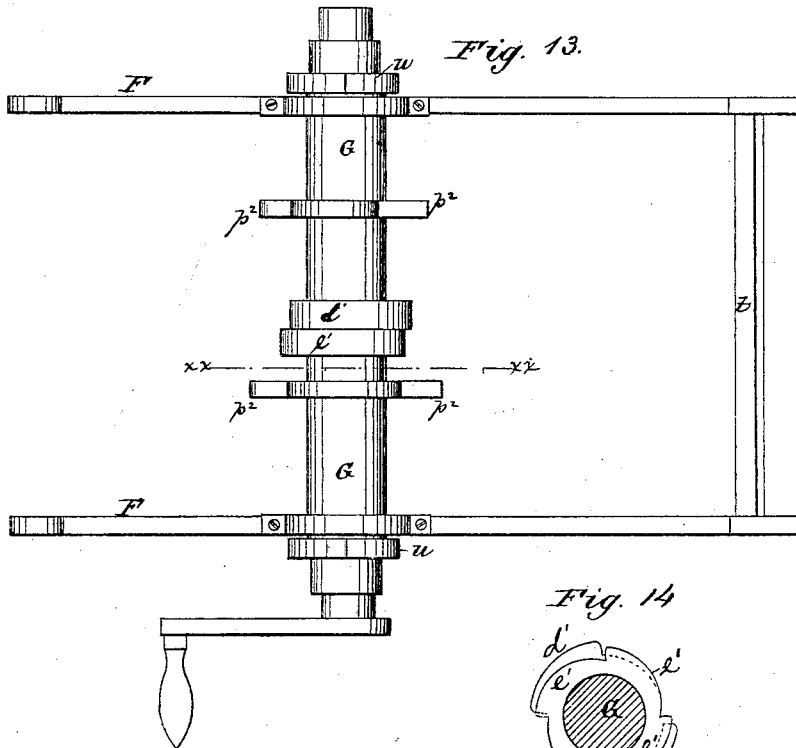
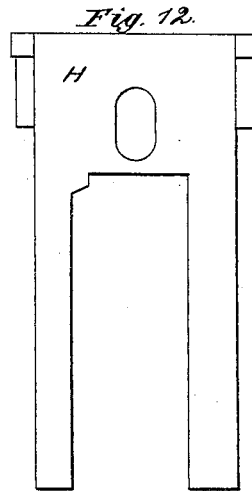
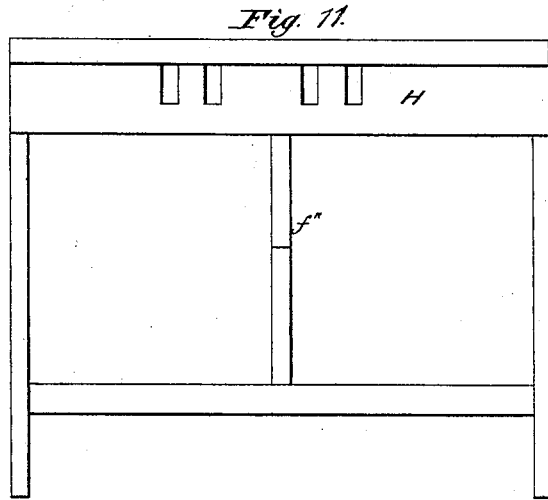

WITNESSES:

W. W. Hollingsworth
J. Kemon

INVENTOR:

R. Verea
BY *Rum*
ATTORNEYS.

UNITED STATES PATENT OFFICE.

RAMON VEREA, OF NEW YORK, N. Y.

IMPROVEMENT IN CALCULATING-MACHINES.

Specification forming part of Letters Patent No. **207,918**, dated September 10, 1878; application filed July 5, 1878.

To all whom it may concern:

Be it known that I, RAMON VEREA, of the city, county, and State of New York, have invented a new and Improved Calculating-Machine, of which the following is a specification:

Figure 1 is a longitudinal section taken on line $x x$ in Fig. 2. Fig. 2 is a sectional plan view. Fig. 3 is a longitudinal section taken on line $y y$ in Fig. 2. Fig. 4 is an inverted plan view. Fig. 5 is a vertical transverse section taken on line $z z$ in Fig. 1. Fig. 6 is a vertical transverse section taken on line $x' x'$ in Fig. 1. Fig. 7 is a detail view of the index-plate. Fig. 8 is a detail view of the sliding table. Fig. 9 is a detail view of the adjusting mechanism. Fig. 10 is a table accompanying the machine. Figs. 11 and 12 are side and end views, respectively, of the vertically-moving frame. Fig. 13 is a plan view of the central or motor shaft and the levers for adjusting the slide which carries the pins. Fig. 14 is a cross section of the shaft on line $x x$, Fig. 13.

Similar letters of reference indicate corresponding parts.

Referring to the drawing, A is the frame of the machine, which contains all of the working parts. For the purposes of this description I have called the end marked a the "front end" of the machine, and the end marked b the "rear end."

In the front end of the frame A there are ways e , in which is placed a sliding frame, B, in which are journaled two hollow decagonal prisms, C C', whose shafts $e e'$ project through the upper bar of the frame, and are provided with pinions $f f'$, which are engaged by detent-springs g , which are secured to the upper bar of the frame B. These pinions are engaged by racks $h h'$, formed on the edges of the plates $i i'$. These plates are both numbered from 0 to 9, the 0 being nearest the prisms C C'.

A table, D, having slots $j j$, is placed above the frame B, and secured to it, so as to confine the plates $i i'$ to their places. Knobs k project from the plates $i i'$ through the slots j in the table D, and are provided with indicator-points l , Figs. 8 and 9, which move along scales m on the table D, at the side of the slots j . These scales are each numbered from 0 to 9.

There are holes n , Fig. 8, through the table

at the inner end of the slots j , through which the figures on the plates $i i'$ may be seen.

In each face of each decagonal prism there are nine holes, o , disposed in two vertical rows. These holes are of different diameters, and the smaller ones vary in depth.

A slide, E, is placed upon vertical guides p , which are supported in the frame A by cross-bars q . The slide E carries two pairs of tapering pins, r , which, when the prisms C C' are thrown backward by the movement of the frame B, enter the holes o , until they strike the bottom or sides of the holes, when the pins are carried along with the prisms. By means of this device the operations of the other parts of the machine are controlled.

The slide E is moved up or down, so as to bring the pins r opposite any of the holes o by means of the levers F, which are fulcrumed on the shaft G and connected with the slide by means of links s . The levers F extend to the extreme rear end of the machine, where they are connected together by a cross-bar, t . The shaft G, which is journaled near the middle of the frame, has, near each end, cams u , which engage lugs v on the arms w , that extend rearwardly from the frame B.

A transverse frame, H, is placed in vertical guides in the middle of the frame A, and in it are placed four horizontal bars, $a' a'' b' b''$, to the forward end of each of which is attached a vertical bar, c' , which corresponds in position to one of the pins r .

The frame H is moved up and down alternately by two cams, $d e'$. These cams are secured together, and are oppositely disposed in respect to each other. They are capable of sliding upon the shaft G, but are prevented from turning independently thereof by a feather on the shaft. These cams are shifted so as to bring either of them into engagement with an apertured plate, f'' , Figs. 3 and 11, secured to the frame H by means of two arms, g^1 , which project downward from a sliding bar, h^1 , that extends longitudinally through the frame H, and is supported by guides formed in the sides of the frame A. Two lugs, Fig. 3, project from the edge of the opening in the plate f'' , and are engaged by one or the other of the cams $d^1 e^1$ when the frame H is raised or lowered.

The rear ends of the bars $a' a'' b' b''$, Fig. 1,

are offset and provided with racks $j' j''$, which may be brought into engagement with pinions k^1 on the shafts of the wheels $U' U''$, which shafts are journaled in standards m^1 , Fig. 2, that project from a cross-bar of the frame A. Adjoining the wheel U' there is a wheel, U''' , which is placed axially in line with the wheels $U' U''$. Above the wheels $U' U'' U'''$ there is a frame, I, which is parallel to the axis of the said wheels, and is supported in guides formed in the frame A. In the frame I there is a rod, o^1 , upon which are placed five wheels, $p^1 q^1 r^1 s^1 t^1$. In the present machine but three of these wheels, $r^1 s^1 t^1$, are required; but the number may be varied to suit the capacity of the machine.

The wheels $r^1 s^1 t^1$ have notches w' , for receiving the teeth of the wheels $U' U'' U'''$. Between these notches there are ten plain surfaces, upon which are placed the figures from 1 to 9; also the cipher. To each of the wheels $p^1 q^1 r^1 s^1 t^1$ a mutilated pinion, v' , is attached, and upon a shaft, w' , are secured as many toothed sectors a^2 as there are pinions v' on the rod o^1 . To one of the toothed sectors, at or near the middle of the machine, is jointed a bar, b^2 , which extends through the top of the frame I, and serves as a handle for moving the sectors a^2 when it is desired to return the wheels $p^1 q^1 r^1 s^1 t^1$ to zero.

The sectors, when moved, carry the pinions v' until a blank space is reached on the pinion, when the cipher will come opposite a slot, c^2 , in the front side of the frame I. The sectors a^2 are returned to their original position, out of the way of the pinions v' , by a spring, d^2 . The rotation of the shaft G moves the frame B rearward, so that the prisms C are brought into engagement with the tapering pins r . When the said pins strike the bottom or sides of the holes o they are carried forward by the prisms C against the vertical bars c' on the ends of the bars a' . When they come into contact with these bars they push them toward the rear of the machine, and thus cause the pinions k and wheels $U' U'''$ to rotate a sufficient distance to bring the proper numbers opposite the slot c^2 .

The distance through which the wheels are rotated depends entirely upon the distance through which the prisms C move before engaging the tapering pins r . The holes o in the prisms C vary from the top to the bottom on each face, and no two faces are alike.

The tapering pins r are moved up and down by the levers F, so that they may be placed opposite any of the holes in the rear face of the prisms, and the position of the prisms, as before observed, is regulated by moving the plates $i' u'$ out or in, according to the scale on the table D.

The height of the pins r is regulated by one of two sliding scales, J, which engage a lever, K, that is pivoted at one side of the frame A, and has a triangular projection, e^2 , which extends nearly to the frame I. The scales J are placed in guide-slots in the rear of the frame I, and are each provided with a projection, f^2 ,

Fig. 7, which extends to the center-line of the machine. One or the other of these scales is used in determining the position of the tapering pins r by engagement with the triangular projection e^2 of the lever K¹, the said lever being arranged to rest on the rear end of the lever F, so that when either of the scales is moved up or down the rear ends of the levers F move with it.

The prisms govern the operations of the machine. They are alike, and the holes in their several faces are made according to the table shown in Fig. 10. The figures in each division of the table represent certain parts of the diameter of the largest hole in the cylinder, 9 representing the largest holes, which are capable of receiving the pins without moving them.

0 is a mere indentation, and from 1 to 9 the holes vary regularly in size, each figure smaller than 9 representing a certain part of 9.

The taper and length of the pins r , as will be noticed, are also proportionate to the diameter of the holes, so that when a pin strikes in a 9-hole it is not moved forward at all. When it strikes in an 8-hole the pin r is moved forward, so as to turn the wheel w' one-tenth of a revolution. When the pin strikes in a 7-hole it moves the wheel w' through two-tenths of a revolution, and so on throughout the entire table; and when the end of the pin strikes in the indentation marked 0 it is carried forward, so as to cause the wheel w' to make nine-tenths of a revolution.

The table is constructed especially for this machine, and is made from the ordinary multiplication-table in the following manner:

Take, for example, $5 \times 5 = 25$. The figures 25 are transposed, making 52. This taken from 99 leaves 47, ($99 - 52 = 47$) the number required for the place of the product of 5×5 in the ordinary multiplication-table. These figures represent holes in the prism, which are of such size as to engage the pins r , so as to move the wheels w' and expose the number 25 through the slot c' .

Directly under the wheels $U' U'' U'''$ there is a rod, g^2 , upon which are placed two sleeves, h^2 . To one end of each sleeve is secured an arm, i^4 , that extends upward in position to be engaged by a pin, j^2 , projecting from the number-wheel w' . Near the other end of the sleeve h^2 there are arms k^2 , upon which are placed sliding forks l^4 . These forks extend upward in position to engage the teeth of the wheels $U' U''$, when the said forks are moved forward or backward by the arms i^4 , and raised by the levers $m^2 m^3$. The levers $m^2 m^3$ are fulcrumed on the rod n^2 , and are connected with the forks by means of links o^2 , Fig. 5. The shorter arm of the lever m^2 is engaged twice during every revolution of the shaft G by the cam p^2 , placed on the said shaft. In front of the rod n^2 , and a little below it, a rock-shaft, q^2 , is journaled in the frame A. Upon this shaft is secured a short arm, r^2 , which engages the shorter arm of the lever m^2 . A short forked

arm, s^2 , is also secured to the rock-shaft q^2 , and is designed to engage the shorter end of the lever m^3 , and to be engaged by the cam p^2 on the shaft G to return the lever m^3 to its normal position after it has been moved so as to raise the fork l^4 . There are three spring-detents, t^2 , secured to a rock-shaft, n^2 , and arranged to strike between the teeth of the wheels $l' l'' l'''$ to cause them to register correctly.

The operation of the machine is as follows: Before beginning any operation take care that all indexes, wheels, and sliding tables mark zero. To write any number, the button h , Fig. 6, ought to be pulled out. If it is desired to multiply a number of units, the index l , that is connected with the prism C, is moved to the multiplier on the table D, and one of the scales J is moved downward until the multiplicand is even with the top of the frame I. The shaft G is now turned in a right-hand direction, carrying the frame B forward until the prisms C engage the tapering pins r and carry them backward against the vertical bars e' , when the bars a' and their racks are carried backward until the wheels $l' l'' l'''$ are rotated so as to show in the slot e'' the product. Should tens enter into the calculation the prism C is brought into use, and the index l , connected therewith, is moved to the proper number, and the operation is performed as before. Should the units-wheel make one revolution it will be registered on the tens-wheel by the action of the fork l^4 , it being thrown into position to engage the tens-wheel by the lever p^2 when the latter is engaged by the pin j^2 on the units-wheel. The hundreds-wheel is turned from the tens-wheel in precisely the same manner.

The reverse motion of the wheels w is secured by shifting the cams d' by means of the rod h^1 , by which the relation of the racks v'' to the pinions k is changed.

To subtract, the indexes l are adjusted to figures on the plate D which represent the subtrahend. The shaft G is then turned until the subtrahend appears in the slot e'' . The slides i are again moved until the indexes l are opposite the numbers representing the minuend. The rod h^1 is then moved so as to reverse the motion of the frame H, and bring the other set of racks, v' , into engagement with the pinions K. The shaft G is now turned, and the racks are carried forward, so as to take the minuend from the subtrahend and have the numbers representing the remainder exposed through the slot e'' .

It is obvious that holes of different depths may be made in the prisms, and that the pins r may be of one diameter throughout. Therefore I do not confine myself to the exact form herein described.

The following are practical examples in addition, subtraction, multiplication, and division:

Addition.—Example: $96+34+27$. Push the second index l till it marks or points 9, and figure 9 will appear in the lateral hole n . Push

the index l till the number 6 will appear in the hole n , making together 96. Give a turn to the main shaft G, and 96 will appear on the wheels in the product-box. For the second amount, 34, push the left index l to 3 and the other to 4, and 34 will appear in the lateral holes n . With another turn to the main shaft 130 will appear in the product-box. To add, now, 27, we have to do the same. Write the numbers in the indexes l , turn the shaft G, and 157 will appear in the product-box, which is the sum of $96+34+27$.

Subtraction.—To subtract, we write the minuend in the index l , as 96, and turn the main shaft. Then we write the subtrahend, say 34, just as we did in the addition; but before turning the shaft we pull out the button h^1 , Fig. 6; 62 will appear in the product-box.

Multiplication.—Example: 86×97 . We write one of these factors on the indexes l , as for adding, and the other on the sliding tables J in the back of the product-box. We move this box as many places to the right as there are numbers in the multiplier, less one. Having written 86 in the indexes and 97 on the sliding tables, and with the product-box in position, we turn once the main shaft G, and the product-case will mark 774, which is the product of 86×9 . Now we move the product-box one place to the left and turn the shaft again, and the product-box will mark 8342, which is the product of 86×97 .

Division.—Example: $8342 \div 86$. We write the dividend in the product-box by transferring from the indexes, and push the to the right, the same as for multiplication. Then we write 86 in the indexes, and pull out the button h^1 , Fig. 6. 83 can hold 8 about nine times, and so we mark 9 in the sliding table J in the back of the box, and give a turn to the shaft; 602 will appear or be left. We move the box one place to the left, and, supposing that 60 will hold 8 seven times, we push down the slide-table on the right to 7, and turn the shaft. Nothing will appear in the product-box. $8342 \div 86 = 97$.

Having thus described my invention, I claim as new and desire to secure by Letters Patent—

1. The combination, in a calculating-machine, of one or more perforated prisms or cylinders, C, and tapered pins r , substantially as and for the purpose herein shown and described.

2. The sliding bars a' , carrying racks i'' , the wheels $u l$, tapering pins r , and perforated prisms C, in combination, substantially as herein shown and described.

3. The combination of the scales J, lever K, levers F, slide E, and tapering pins r , substantially as herein shown and described.

4. The combination of the lever i^4 , the arm l^2 , fork l^4 , and mechanism for operating the same, the wheels r^1 , having the pins j^2 , and the wheels l' , substantially as herein shown and described.

5. The bars a' , frame H, having the plate

f'' , and the cams $d^1 e^1$, in combination, substantially as herein shown and described.

6. The graduated plates i , carrying racks h and indexes l , the graduated table D, and the prisms C C', having pinions $f f'$, in combination, substantially as herein shown and described.

7. The combination of the toothed sectors

a^2 and the mutilated pinions v' with the wheels r^1 , substantially as herein shown and described.

RAMON VERA.

Witnesses:

GEO. M. HOPKINS,
C. SEDGWICK.