

R. G. WOOD.  
Sewing-Machine.

No. 207,928.

Patented Sept. 10, 1878.

FIG. 1.

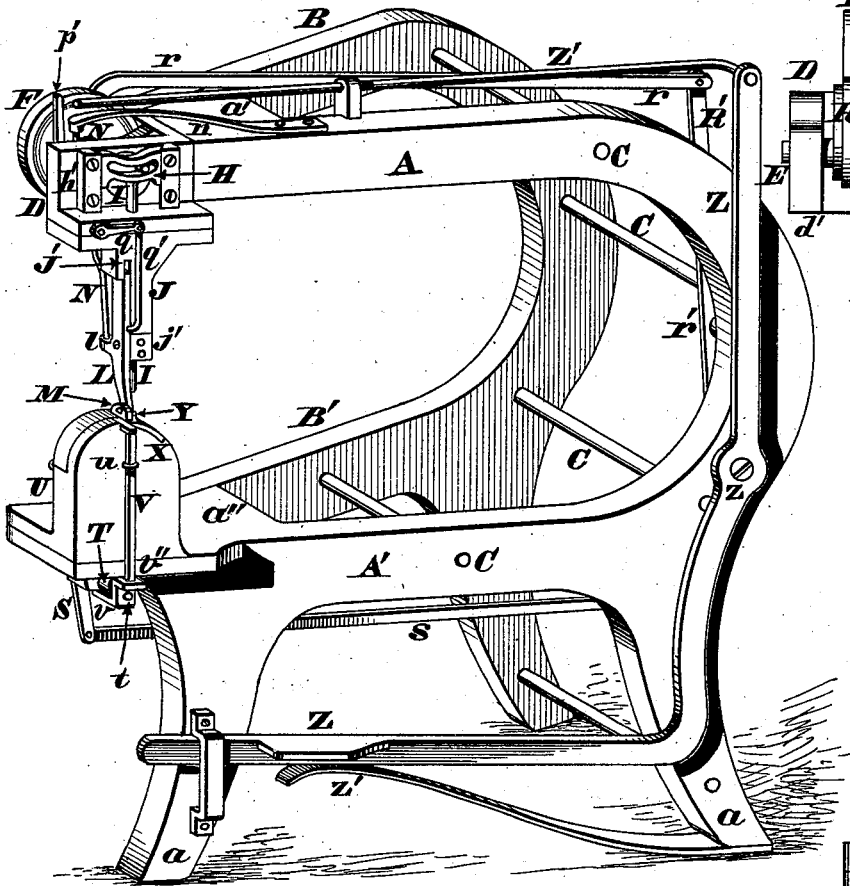

FIG. 3.

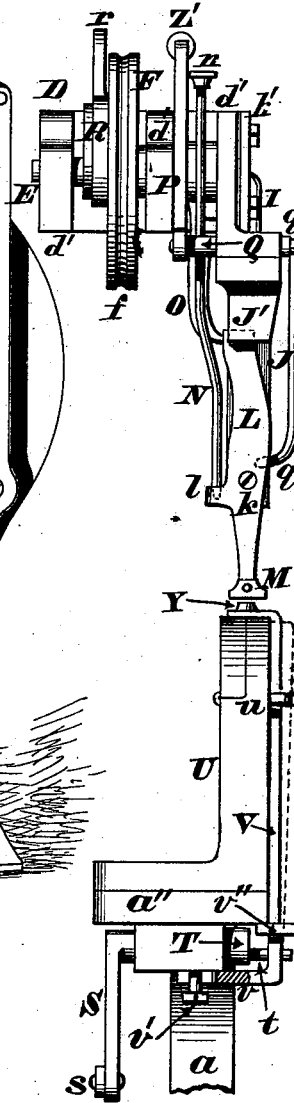

FIG. 11.

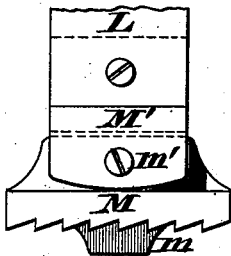
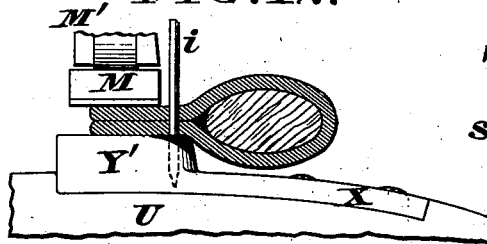

FIG. 12.



Attest.  
C. W. Layman  
Esq.

Inventor.  
Richard G. Wood  
By James H. Layman  
His Attorney

R. G. WOOD.  
Sewing-Machine.

No. 207,928.

Patented Sept. 10, 1878.

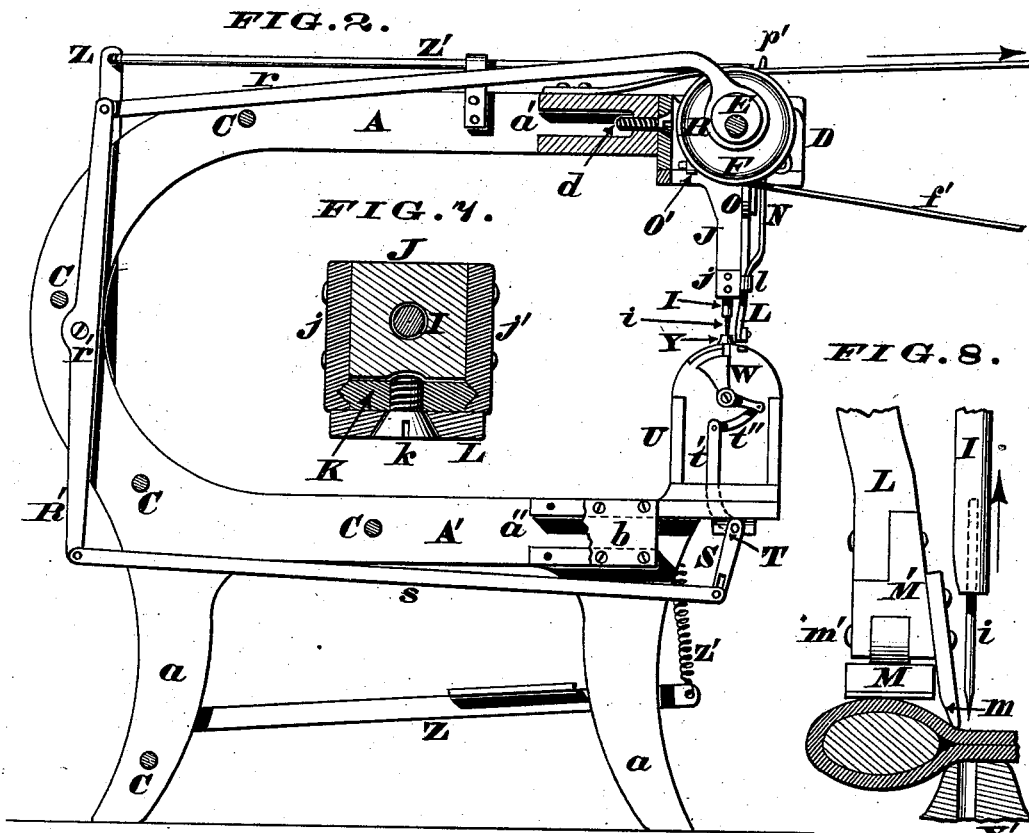

FIG. 4.

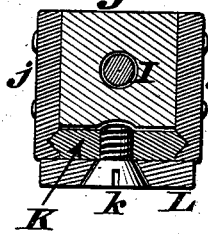

FIG. 8.

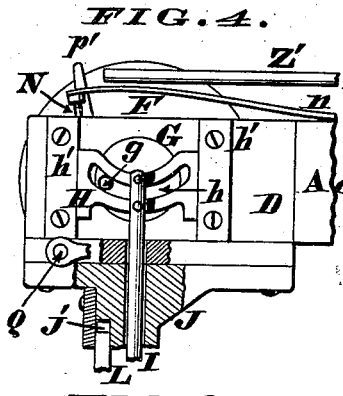
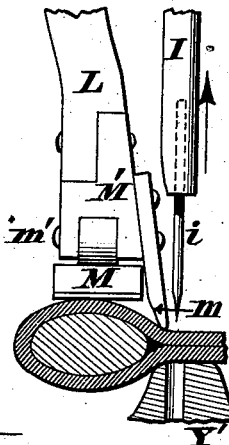

FIG. 9.

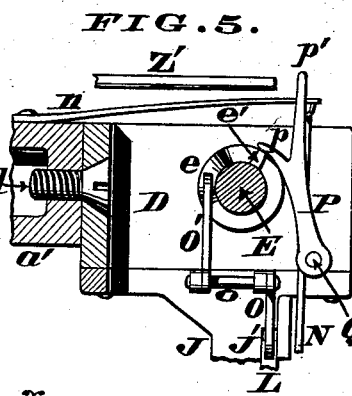
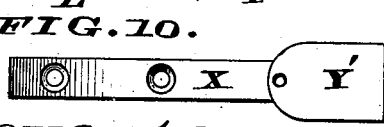
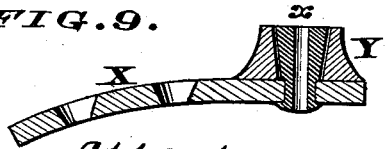
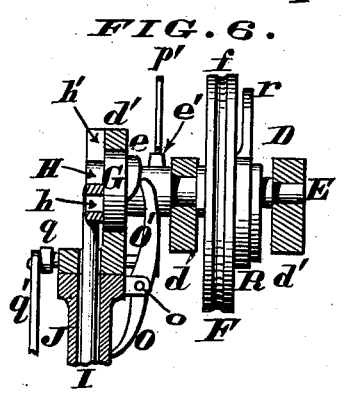

FIG. 10.



Attest.  
J. W. Layman,  
S. M. Bond

Inventor.  
Richard G. Wood  
by James W. Layman,  
his Attorney.

# UNITED STATES PATENT OFFICE.

RICHARD G. WOOD, OF CINCINNATI, OHIO.

## IMPROVEMENT IN SEWING-MACHINES.

Specification forming part of Letters Patent No. **207,928**, dated September 10, 1878; application filed May 14, 1878.

*To all whom it may concern:*

Be it known that I, RICHARD G. WOOD, of Cincinnati, Hamilton county, Ohio, have invented certain new and useful Improvements in Sewing-Machines, of which the following is a specification:

This invention relates to that class of sewing-machines which are employed for stitching the customary leather coverings on carriage dashes, bows, fenders, guards, &c.; and the first part of my improvements comprises a novel construction of the main frame of the machine. This frame consists, essentially, of two stout  $\text{D}$ -shaped castings, disposed vertically, and united by a system of ties or braces, so as to afford a structure of about thirty degrees divergence, the head which carries the needle-driving mechanism being situated at the junction of the upper limbs of said frame, while the work-supporting pedestal is located at the junction of the lower limbs of the frame, as hereinafter more fully described, and pointed out in the claims. This arrangement affords an unusually stiff or rigid frame, which is perfectly free from any injurious lateral vibration, no matter at what speed the machine may be driven. By thus avoiding lateral vibration the operative parts of the machine are caused to act with the utmost accuracy, as hereinafter more fully explained.

The second part of my invention consists in providing this head with a downwardly-projecting neck, to which neck is fitted the needle-bar, feeding device, &c. The object of this neck is to afford sufficient clearance between the needle-plate and the elevated portion of the main frame to permit the convenient handling of dashes with their projecting foot-irons, as hereinafter explained.

The third part of my invention consists in applying to the pedestal of the machine a lifting-bar, which is operated by suitable devices so as to coact with the feed-lever in moving the work the required distance for a single stitch, as hereinafter more fully described, and pointed out in the claims. This feed-lever oscillates and plays vertically on a bearing or fulcrum-block applied to the depending neck, and has pivoted to its lower end a serrated foot, which foot is provided with a lip that presses down against the material being

stitched, and thereby prevents the latter being lifted by the friction of the ascending needle with said material. By this arrangement is prevented the derangement of the loop of the thread through which the shuttle is to be driven.

The fourth part of my invention comprises a novel combination of spring and lifter with the aforesaid feed bar or lever, whereby the latter is caused to assume its normal position as soon as it is liberated from the pressure of the operating cam or eccentric, as more fully described hereinafter.

The fifth part of my invention consists in applying to sewing-machines a treadle, whose depression by the attendant will at once elevate the feed-bar, and thereby render the feed inoperative for the time being.

In the annexed drawings, Figure 1 is a perspective view of my improved sewing-machine. Fig. 2 is a vertical section of the same, taken in the plane of the devices that operate the shuttle-carrier. Fig. 3 is an elevation of the principal operative parts of the machine on an enlarged scale. Fig. 4 is a front elevation of the needle-bar cam, the upper portion of the neck of the machine being shown in section. Fig. 5 is a section of the head of the machine, taken transversely of the driving-shaft. Fig. 6 is another section of said head, but taken longitudinally of the shaft, which shaft and its accessories are shown in elevation. Fig. 7 is a horizontal section of the neck, taken in the plane of the feed-bar pivot. Fig. 8 represents the manner in which the lip of the feed-foot retains the work down upon the raised needle-plate while the needle ascends. Fig. 9 is a vertical section through the preferred form of my needle-plate. Fig. 10 is a plan of a modified form of needle-plate more especially adapted for use in stitching coverings on carriage-bows. Fig. 11 is an elevation of the feed-foot; and Fig. 12 shows the manner of using the needle-plate seen in Fig. 10.

A represents the upper, and A' the lower, limb of one portion of the main frame, said limbs being preferably cast in one piece, and having the represented  $\text{D}$  shape. *a* are the legs or feet or other supports of this part of the frame. Furthermore, these limbs are provided with horizontal flanges *a'*, to receive

screws or bolts *b*, wherewith the limbs B B' are rigidly united to the ones A A'. These two members, A A' and B B', of the frame are essentially the same, with the exception of the omission of the left leg from the limb B'.

C represents a system of tie rods or braces, wherewith the two portions A A' and B B' are bound together, said rods and the flanges *a' a''* being so arranged as to impart a triangular shape to the horizontal section of the main frame, as clearly shown in Fig. 1. These members A A' and B B' diverge at an angle of about thirty degrees; but this divergence may be varied without impairing the efficiency of the machine, as the object of the angular frame is to afford an extended base without unduly increasing the weight of said frame. This extended base insures the utmost stability of the machine and effectually prevents lateral vibration of the same.

Secured to the upper flanges, *a'*, by means of bolts *d*, is a heavy cast-iron head, D, whose vertical webs *d'* afford journal-bearings for a driving-shaft, E, that carries a pulley, F, which pulley F serves also as a balance-wheel for the machine. This pulley may be grooved at *f* to receive the driving-band *f'*, (see Figs. 2 and 3,) or shaft E may be driven by any other instrumentality. One end of said shaft carries a cam-wheel, G, whose cam-roller and stud *g* traverses the eccentric-slot *h* of a vertically-reciprocating cam, H, which latter is confined to a proper path by guides *h'*, bolted to the head D. Secured rigidly to this cam H is a bar, I, to whose lower end a needle, *i*, is attached, said bar being adapted to reciprocate within a suitable channel in neck J, which latter depends from the head D. This neck may be cast in one piece with said head; but I prefer making it separate and bolting it thereto, as seen in Fig. 4. Attached to the lower end of this neck are two cheeks, *j j'*, whose inner faces are provided with V-shaped grooves, which guide a vertically-reciprocating fulcrum-block, K, to which is coupled by pivot *k* an oscillating or vibrating feed-bar, L, as seen in Fig. 7. The extreme lower end of this bar has screwed to it a bearing, M', whose extremity is crowning, as seen in Fig. 11, and said bearing has pivoted to it at *m'* a serrated foot, M.

*m* is a lip or stop, for a purpose that will presently appear.

Projecting laterally from bar L is a lug, *l*, that receives the stress of a rod, N, against whose upper end the spring *n* bears, said spring being secured to the limb A of the main frame. The upper end of this feed-bar L is adapted to play within a slot, J', of neck J, and is vibrated toward the front of said neck by a finger, O, secured to one end of a rock-shaft, *o*, whose other end has an arm, O', that is operated at the proper moment by a cam, *e*, of cam-wheel H. Furthermore, this driving-shaft has a raising-cam, *e'*, adapted to strike the spur *p* of an arm, P, that is attached to one end of another rock-shaft, Q, which shaft is journaled transversely of the head D, as

seen in Fig. 6. The other end of this shaft Q has an arm, *q*, from which depends a rod, *q'*, that serves to lift the feed-bar L and its foot M. Arm P has an upward prolongation, *p'*, whose duty will presently appear.

Keyed to driving-shaft E is an eccentric, R, having a connecting-rod, *r*, that oscillates the rocker R', which latter is pivoted at *r'* to the bend of frame A A', as seen in Fig. 2. Pivoted to the lower end of this rocker is another rod, *s*, that operates the arm S of a rock-shaft, T, located beneath the pedestal U, which latter is securely bolted to the flange *a''* of the main frame; or this pedestal may be otherwise attached to said frame.

This rock-shaft has a wrist, *t*, adapted to elevate a raising-bar, V, which is confined to pedestal U, with staple *u*, the lower end of said bar being furnished with a slotted foot, *v*, to receive a screw, *v'*, as seen in Fig. 3.

*v''* is a stop that limits the upward motion of said bar V. Furthermore, this rock-shaft T has attached to it an arm, *t'*, whose link *t''* communicates motion to an oscillating carrier, W, which carrier may be provided with a suitable shuttle. Fitted to the upper or crowning end of pedestal U is a tongue, X, having a conical tubular pivot, *x*, or the rotary needle-plate Y, as seen in Fig. 9; or this raised needle-plate may be immovable with reference to the tongue, as represented at Y' in Figs. 8, 10, and 12; but when this needle-plate is immovable it must be perforated to permit the passage of the needle. It is preferred, however, to employ the needle-plate Y, because it is rotated by the advancing dash, or other work, and consequently there is but little friction generated by its use. Z is a treadle, pivoted to frame A A' at *z*, and carrying a rod, Z', that is adapted to impinge against the prolongation *p'* of arm P as soon as said treadle is depressed by the attendant's foot. *z'* is a suitable spring, that maintains rod Z' out of contact with said prolongation; but, if preferred, a weight or counter-balance may be substituted for this spring. Finally, the machine may be provided with any approved take-up motion and stitch-setter; but, as such devices are old and well-known, further description of them is unnecessary in this specification.

The operation of my machine is as follows: The needle *i* and the shuttle applied to carrier W, are provided, respectively, with the upper and lower threads in the usual manner; and the attendant then stations himself so as to face the frame A A', the pedestal U being near his left hand, while treadle Z is convenient for his right foot.

In applying the work to the machine, said treadle is first depressed, which act brings the left or free end of rod Z' in contact with prolongation *p'* of arm P, thereby rocking shaft Q in its bearings and causing lifter *q'* to elevate feed-bar L and foot M a sufficient distance above the end of pedestal U to permit the insertion of the dash or other frame to which the covering is to be stitched. The

margin of the dash-frame is then brought up snugly against needle-plate Y, and the pressure is then removed from treadle Z, thus leaving the spring *n* at liberty to exert its normal or downward stress against the lug *l* of feed-bar L. Now, by referring more particularly to Fig. 3 it will be noticed that this lug is located at the rear side of bar L, and below its pivot *k*, and, consequently, the pressure of said spring coacts with the upward pull of lifter *q'*, and thereby simultaneously elevates and swings the lower end of said bar to the front, or toward the operator; but as soon as cam *e* comes in contact with arm O' the finger O is forced against the upper end of said bar, thus shifting it to the front of slot *j'*, and throwing the foot M rearwardly with reference to the attendant.

As the dash-frame with its attached foot-irons and coverings is quite heavy, it is evident considerable labor would be imposed upon the bar L and foot M in feeding the work along upon the pedestal U unless some expedient were adopted to overcome the friction. But this difficulty is obviated by the provision of the lifting-bar V, which is elevated by the wrist *t* just before the feed-movement of foot M is initiated, and the dash is thus caused to clear the pedestal for the time being, and rests solely upon the upper end or lateral extension of said lifting device V. As bar V is now supported by wrist *t*, said wrist serves as a pivot upon which the work is balanced, and, therefore, no labor is imposed upon the device M as it feeds the work. This feeding-motion of my machine is effected by the work being gripped between foot M and the lateral projection of lifting-bar V, and as the former swings rearwardly, bar V vibrates or oscillates accordingly upon its pivot or suspension point *t*, which vibration of the bar will evidently be exactly proportioned to the stroke of said foot M; or, in other words, it will advance the work the required distance for a single stitch.

It will thus be seen that said bar has no positive lateral motion of its own, but is actuated solely by the feed-foot, and, consequently, the action of these two members, M and V, are in perfect unison with each other.

Furthermore, by thus actuating said bar by the motion of the feed-foot, I avoid the complexity of parts and the liability of derangement that would occur in case a cam or other special appliance were provided to operate said bar. While this bar is being lifted, spring *n* yields sufficiently to allow a corresponding elevation of the feed-bar L and its attachments.

As soon, however, as the foot has completed its feeding-stroke said bar V is dropped, and its weight causes it to assume the position indicated by dotted lines in Fig. 3, from which position it is again elevated and thrown rearwardly in unison with the movement of foot M, as just described. The moment foot M has finished its feeding-stroke, raising-cam *e'* comes in contact with spur *p*, thereby rocking

shaft Q, so as to raise the bar L and foot M far enough to throw the latter out of contact with the work. As the elevation of lifter *q'* occurs while spring *n* is exerting its full force against the lug *l*, and as the latter is located below pivot *k*, the feed device M at once swings toward the operator, and is in position for the next stroke.

While needle *i* is being withdrawn from the work the lip *m* presses firmly, but not injuriously, upon the upper covering of the dash, as seen in Fig. 8, which precaution prevents the previously-made loop being drawn out by the springing of the coverings incidental to the retraction of the needle, and, therefore, none of the stitches are missed, but they are all completed in the most regular and perfect manner. As soon as the stitching has been completed as far as one of the cross-bars that constitute the panels of the dash-frame, said cross-bar comes in contact with lip *m*, and the latter thus serves as a stop or guard, which indicates to the attendant the exact moment when the machine is to be stopped, or when the dash is to be turned on the needle preparatory to sewing along the edge of said cross-bar.

The length of the downwardly-projecting neck J enables my machine to perform work that has heretofore been considered impossible—that is to say, it allows the expeditious covering of such dash-frames as have their foot-irons attached, as the distance between needle-plate Y and head D is so great as to afford the most ample clearance for said foot-irons or any other projecting members of such frames or fenders, &c. Furthermore, this clearance afforded by neck J allows curved dash-frames, or any other bent or irregular shaped frames, to be stitched with the utmost facility.

Another advantage is obtained by journaling the principal operative parts in the removable head D, which latter is bolted to the main frame in such a manner as to be readily detached in case the shaft E or any of its accessories should be rendered inoperative from any cause whatever. In this event a new head with its attachments can be applied to the machine in a few minutes, and the injured parts can be repaired at leisure.

Another advantage is obtained by locating the head D and pedestal U at the apex of the angular frame A A' B B' C, as this arrangement preserves the bar I accurately in line with the aperture of needle-plate Y or Y', although the machine may be driven at the very highest speed and may be stitching work of an unusual thickness.

In case it should be desired to stitch coverings on carriage-bows and other tapering frames, &c., the lip *m* is unscrewed from its bearing M', and the stationary needle-plate Y' is used, as seen in Fig. 12. By referring to this illustration it will be noticed that the feed-foot M now acts on the projecting edge of the coverings, and not directly on the bow,

and consequently the tapering form of said bow does not in the least interfere with the proper working of the machine.

Needle-plate Y, instead of being journaled upon the stud *x*, may rotate within a ring applied to the tongue X, or within a suitable recess in said tongue.

I claim as my invention—

1. The combination of the two  $\cap$ -shaped castings A A' B B', united by ties, as described, the head D, located at the junction of the upper limbs, A B, and the work-supporting pedestal, located at the junction of the lower limbs, A' B', substantially as and for the purposes set forth.

2. The combination of the lifting-bar V and mechanism, substantially as described, for actuating the same, and the feed-lever L and mechanism, substantially as described, for operating it, whereby as the feed-lever is lowered to move the material the said lifting-bar is operated to raise said material from the needle-plate against the feed-foot, and move therewith the required distance for a single stitch, as set forth.

3. The vertically-reciprocating and laterally-vibrating feed-bar L, provided with lug *l* and projecting lip *m*, in combination with rod N, spring *n*, lifter *q'*, and mechanism, substantially as herein described, for actuating said rod N and lifter *q'*, for the purposes described and set forth.

4. The vertically-reciprocating and laterally-vibrating feed-bar L, provided with lug *l*, in combination with rod N, spring *n*, finger O, rock-shaft *o*, arm O', driving-shaft E, cam *e*, tappet *e'*, arm P, spur *p*, rock-shaft Q, lever *q*, and lifter *q'*, substantially as herein described, and for the purpose set forth.

5. The combination of head D, provided with the neck J, grooved cheeks *j j'*, reciprocating fulcrum-block K, pivot *k*, feed-bar L, and mechanism, substantially as described, for actuating said feed-bar, for the purposes set forth.

6. The combination of driving-shaft E, eccentric R, rod *r*, pivoted rocker R' *r'*, connection *s*, arm S, rock-shaft T, wrist *t*, and raising-bar V, substantially as herein described, and for the purpose set forth.

7. The combination of treadle Z, pivoted at *z*, rod Z', spring *z'*, arm P *p'*, rock-shaft Q, lever *q*, lifter *q'*, and feed-bar L, substantially as herein described, and for the purpose set forth.

In testimony of which invention I hereunto set my hand.

RICHARD G. WOOD.

Witnesses:

JAMES H. LAYMAN,  
D. A. SOUTHWORTH.