

W. E. SHERRIFFS.
Combined Overflow and Outlet Connection for Bowls, &c.
No. 208,044. Patented Sept. 17, 1878.

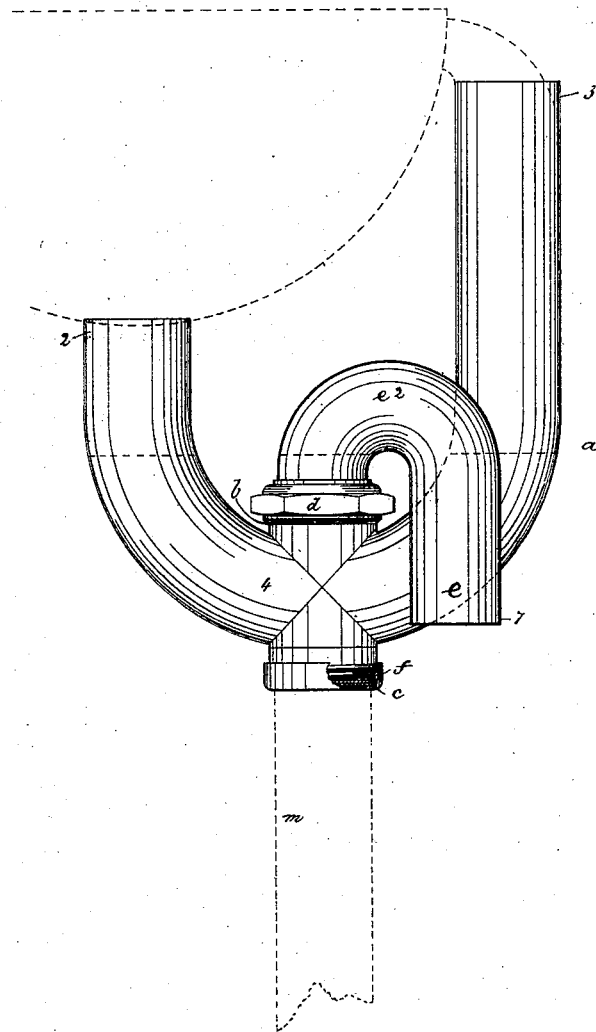

Witnesses.

W. J. Pratt.
L. A. Foster

Inventor.

William E. Sherriffs
by Crosby & Gregory Attys

UNITED STATES PATENT OFFICE

WILLIAM E. SHERRIFFS, OF BOSTON, MASSACHUSETTS.

IMPROVEMENT IN COMBINED OVERFLOW AND OUTLET CONNECTIONS FOR BOWLS, &c.

Specification forming part of Letters Patent No. 208,044, dated September 17, 1878; application filed March 8, 1878.

To all whom it may concern:

Be it known that I, WILLIAM E. SHERRIFFS, of Boston, county of Suffolk, State of Massachusetts, have invented an Improvement in Combined Overflow and Outlet Connections for Bowls, Sinks, &c., of which the following is a specification:

This invention relates to improvements in combined overflow and outlet connections to be used with lavatory or wash-bowls, sinks, &c.

The invention consists, primarily, in a compound pipe which connects the overflow with the outlet at the base of the bowl, such pipe being joined with a waste-pipe; also, in the combination, with a compound pipe connected at its ends with the overflow and outlet, of a waste-pipe having a return-bend to form a water-trap, substantially as hereinafter described.

The drawing, in full lines, shows the compound pipe and waste-pipe with return-bend connected to form a trap.

The compound pipe *a*, shaped preferably as shown in the drawing, and made preferably of cast-lead or other lead compound, is adapted to be connected at its end 2 with the usual coupling-pipe at the outlet or waste opening at the bottom of a bowl or sink, in the usual way, and the end 3 will be joined in any suitable way with the usual overflow.

The dotted lines above the ends of the compound pipe represent a bowl.

At the curved portion 4 of the pipe *a* are added at top and bottom, and firmly secured, sleeves *b* *c*, each provided with screw-threaded portions.

The sleeve *b* receives, as in full lines, a loose coupling-nut, *d*, which surrounds the return-bend *e* at the end of the waste-pipe *e*, and, cooperating with a flange at the end of *e* within the nut *d*, holds the end of the waste-pipe and sleeve *b* closely together, a suitable packing between them preventing leakage of water.

Upon the sleeve *c* is placed a cap, *f*, to cover it water-tight.

The end 7 of the waste-pipe will be continued downward, or joined in any usual way with a pipe, to carry the water discharged from the bowl to a closet or other suitable place.

It is obvious, with the parts constructed and connected as so far described, that the water

passing through the usual plugged outlet at the bottom of the bowl, or from the usual overflow-openings at the top of the bowl, will be obliged to flow upward and away through the return-bend and waste-pipe, and that a certain portion of such water will always remain in the curved lower portion of the compound pipe, and will act as a trap to thereby prevent sewer-gas coming into the room through either the unplugged opening at the base of the bowl or the overflow-openings.

If it is desired to remove sediment or other matter from the compound pipe *a*, the cap *f* may be removed, giving free access to the trap.

In cases where the waste from the bowl passes to a good and efficient trap located in the closet, then, if desired, the cap *f* may be applied upon the sleeve *b*, closing it, and a pipe (designated by dotted lines *m*) or a tail-piece may, by a loose nut, like *d*, be connected with the sleeve *c*, and lead the waste-water directly to the closet.

Instead of the particular return-bend described, I may use any other equivalent connection with the bent portion 4 of the compound pipe which will maintain the water sufficiently high in the legs of pipe *a* to prevent the passage of air or gas.

I claim—

1. The compound pipe adapted to be connected with the outlet at the bottom of a bowl or sink and the overflow-opening, as described.

2. The compound pipe adapted to be connected with the outlet at the bottom of a bowl or sink and the overflow-opening, as described, in combination with a return-bend to maintain the water in the compound pipe at the proper level to form a trap, substantially as described.

3. The compound pipe, bent as described, and the threaded sleeves *b* *c*, combined with a waste-pipe and a cap, to operate substantially as described.

In testimony whereof I have signed my name to this specification in the presence of two subscribing witnesses.

WILLIAM E. SHERRIFFS.

Witnesses:

G. W. GREGORY,
L. A. BAXTER.