

S. H. BRADFORD.
Tin-Can.

No. 208,065.

Patented Sept. 17, 1878.

Fig. 1.

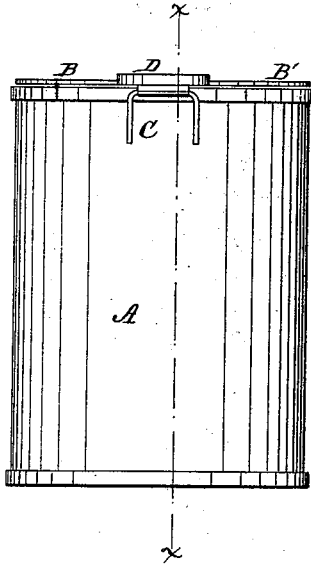

Fig. 2.

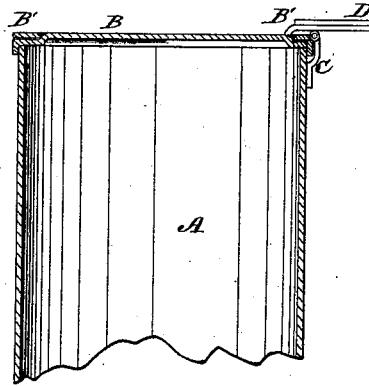
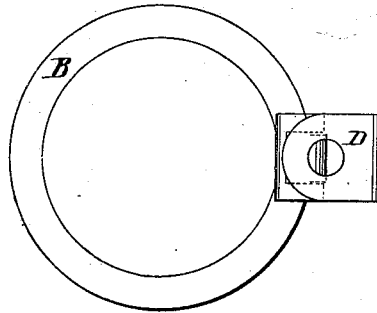

Fig. 3.



WITNESSES:

W. W. Hollingsworth
John O. Kemon

INVENTOR:

S. H. Bradford

BY

Wm. O. C.

ATTORNEYS.

UNITED STATES PATENT OFFICE.

S. HINCKSON BRADFORD, OF NEW YORK, N. Y.

IMPROVEMENT IN TIN CANS.

Specification forming part of Letters Patent No. 208,065, dated September 17, 1878; application filed January 30, 1878.

To all whom it may concern:

Be it known that I, S. HINCKSON BRADFORD, of the city, county, and State of New York, have invented a new and Improved Tin Can, of which the following is a specification:

In the accompanying drawings, Figure 1 represents a side elevation of my improved tin can for condensed milk and other articles. Fig. 2 is a vertical section; and Fig. 3, a top view of ring.

Similar letters of reference indicate corresponding parts.

This invention is designed to furnish for condensed milk, paints, and other articles an improved can, which has the advantage of being provided with a hinged lid, so that the lid may be raised or lowered with great facility and the contents of the can protected effectively against dust and flies.

One of the objections to the present cans for condensed milk, paints, &c., is that the contents, when the cans are opened, are exposed to the entrance of dust, flies, &c., so as to be deteriorated and rendered useless in a comparatively shorter time than when properly covered.

My invention has for its object to provide the cans with a hinge attachment that furnishes a nicely closing and hinged lid when the top is cut open.

A represents a tin can as used for condensed milk, paints, and articles of similar nature, which are intended to be kept for some time in the can for use. The top B of the can is made of lighter material than the body, such as tin-foil, and soldered to a stationary and grooved ring, B', and to the rim of the can, so

as to be readily cut by inserting the knife between ring and rim of can.

To the top and body of the can is soldered, either at the inside or outside, a hinge device, C, of wire or other suitable material, so that when the top is cut by a knife it may be swung into open position by means of the hinge-connection.

A finger-rest, D, is attached to the ring and folded down over the top of the lid, so as to admit of the convenient raising or lowering of the lid either by pressing with the finger on the outwardly-extending finger-rest D or releasing the finger from the same. The lid has to be cut close to the rim of the can-body, and will then nicely close afterward, so as to protect the contents of the can.

Having thus described my invention, I claim as new and desire to secure by Letters Patent—

1. A sealed tin can for condensed milk, paints, &c., having the top and can-body connected by a hinge device, substantially as and for the purpose described.

2. A sealed tin can having a top with stationary ring, connected to the body by a hinge device, and provided with a finger-rest, attached to the top and folded back over the same or down alongside the can-body, so that by cutting the top and raising the finger-rest a hinged lid with thumb-piece is obtained, substantially as specified.

S. HINCKSON BRADFORD.

Witnesses:

PAUL GOEPEL,
C. SEDGWICK.