

C. HEINEN.  
Brake-Shoe Clamp.

No. 208,092.

Patented Sept. 17, 1878.

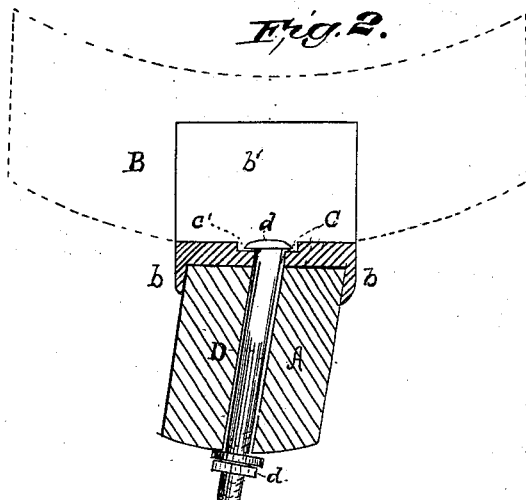
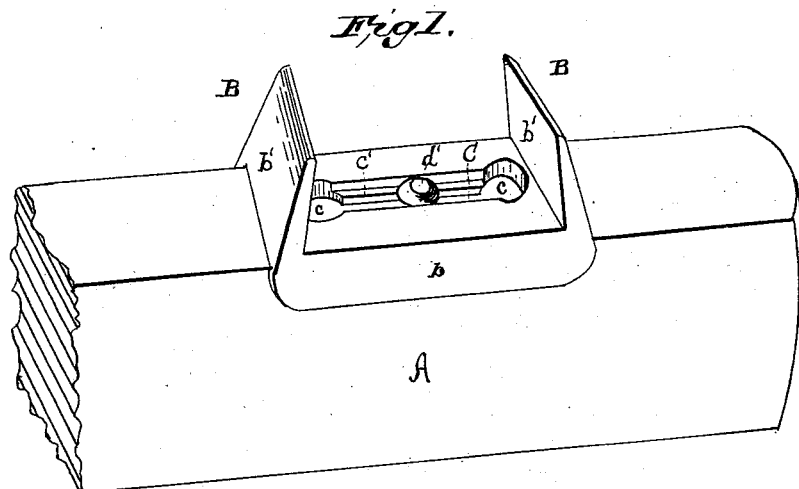

WITNESSES.

*A. Rerthrong.*  
*James H. Lange.*

INVENTOR.

*Christopher Heinen.*  
*per Adam P. Pro's,*  
*Attorneys.*

# UNITED STATES PATENT OFFICE.

CHRISTOPHER HEINEN, OF LEAVENWORTH, KANSAS.

## IMPROVEMENT IN BRAKE-SHOE CLAMPS.

Specification forming part of Letters Patent No. 208,092, dated September 17, 1878; application filed March 15, 1878.

*To all whom it may concern:*

Be it known that I, CHRISTOPHER HEINEN, of Leavenworth, in the county of Leavenworth and State of Kansas, have invented certain new and useful Improvements in Brake-Shoe Clamps; and I do hereby declare that the following is a full, clear, and exact description thereof, which will enable others skilled in the art to which it appertains to make and use the same, reference being had to the accompanying drawings, and to letters of reference marked thereon, which form a part of this specification, and in which—

Figure 1 is a perspective view of my improved brake-shoe clamp, and Fig. 2 is a vertical transverse section thereof, representing the shoe in dotted lines.

Corresponding parts in the two figures are denoted by like letters.

This invention appertains to certain improvements upon my wagon-brake covered by Letters Patent dated September 18, 1877, No. 195,275, and refers particularly to the clamping device for holding the brake-shoe.

The nature of the present invention consists in constructing the shoe-clamps with longitudinal slots and recesses, which receive a nutted and headed bolt, substantially as hereinafter more fully set forth.

In the annexed drawing, A marks the ordinary brake-bar, in practice adjusted upon extensions of the rear hounds of the vehicle, and connected, by rods or otherwise, to the brake-operating mechanism. B is a clamp, of which two are used in connection with the bar A, one attached to each end of the latter to connect the shoes or rub-blocks thereto. The clamp B is provided with longitudinal flanges *b b*, which embrace the bar A and assist in holding the clamp or clamps in position thereon. The clamp B is also provided with convergent jaws *b' b'*, to enable the shoe or rub-block to be clamped between the same.

Thus far what has been described is com-

mon with my invention as set forth in the Letters Patent above mentioned.

The description of the improvement is as follows: The clamp is provided in the direction of its length with a slot, C, terminating into apertures *c c*, and upon each side of this slot is a recess, *c'*, which recesses form shelves or flanges for the heads of the bolts to rest against, as seen in Fig. 2. Through the slot C passes the bolt D, for securing the clamp and its shoe or rub-block to the brake-bar A, the said bolt also passing through said bar, and nutted or pinned thereto, as at *d*. The bolt D is introduced into the slot C through one of the apertures *c*, they being sufficiently large to permit of the reception of its head *d'*. When the bolt D is in position in its slot the flanges of its head *d'* will rest in the recesses *c' c'*, and when tightened be firmly clamped in position.

By this construction and combination of parts the clamp and its shoe or rub-block are rendered readily and easily detachable, and the shoe or block can be adjusted with reference to the wheel so as to also present the unworn surface thereof to the wheel. A further advantage consists in having to use but a single bolt for each clamp.

Having thus described my invention, what I claim, and desire to secure by Letters Patent, is—

The brake-shoe clamp B, provided with the longitudinal slot C, and upon each side of said slot with a recess, *c'*, in combination with a headed and nutted bolt, D, and bar A, substantially as and for the purpose set forth.

In testimony that I claim the foregoing as my own I hereunto affix my signature in the presence of two witnesses.

CHRISTOPHER HEINEN.

Witnesses:

JOSEPH DREES,  
ED. RUPPERT.