

H. G. THOMPSON.
 Lasting Mechanism for Boots and Shoes.
 No. 208,127. Patented Sept. 17, 1878.

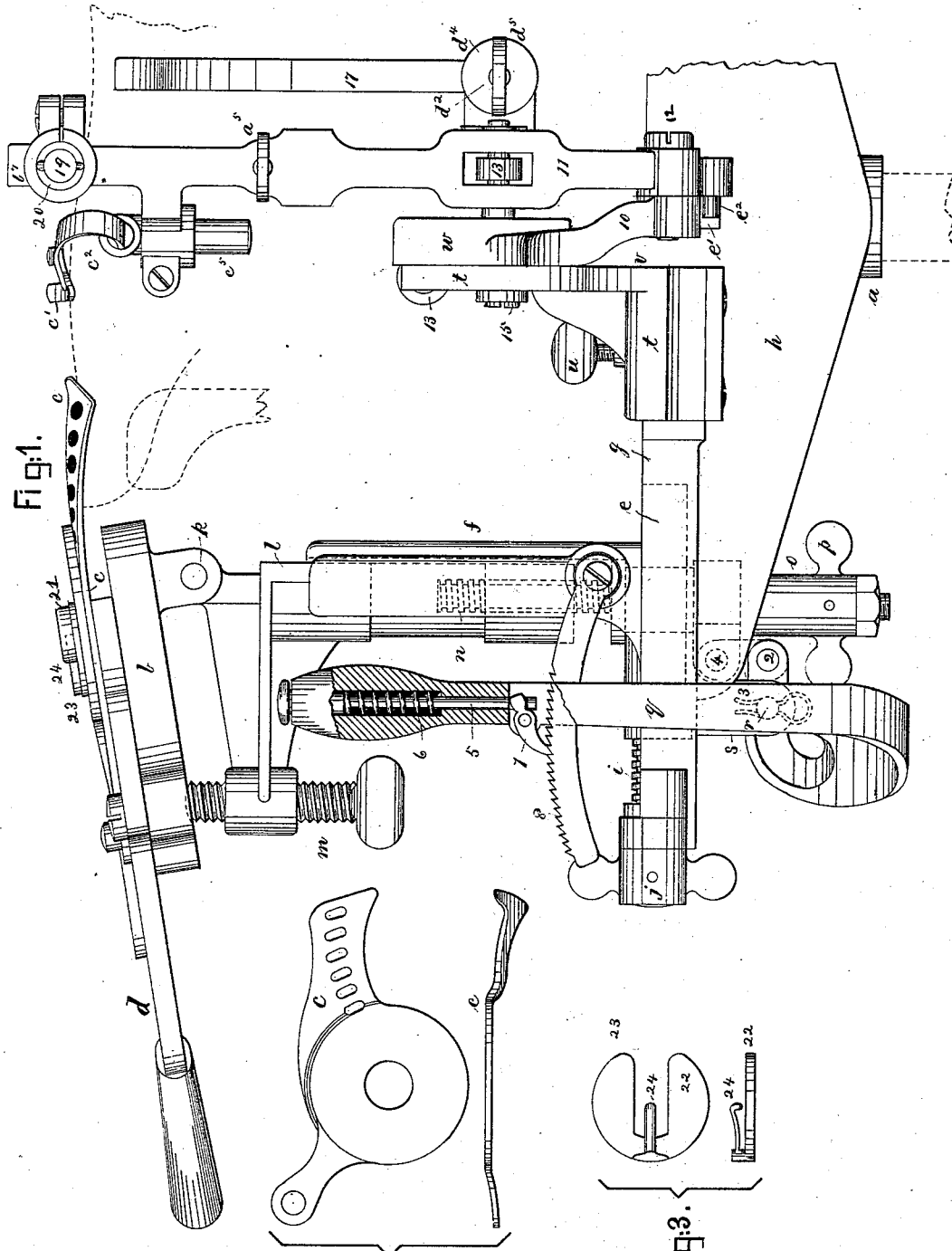

Witnesses.
N. E. Whitney
L. J. Connor

Fig 2.

Fig. 3.
 Inventor.
Henry G. Thompson
 by *Looby & Gregory* Attys

H. G. THOMPSON.
Lasting Mechanism for Boots and Shoes.
No. 208,127. Patented Sept. 17, 1878.

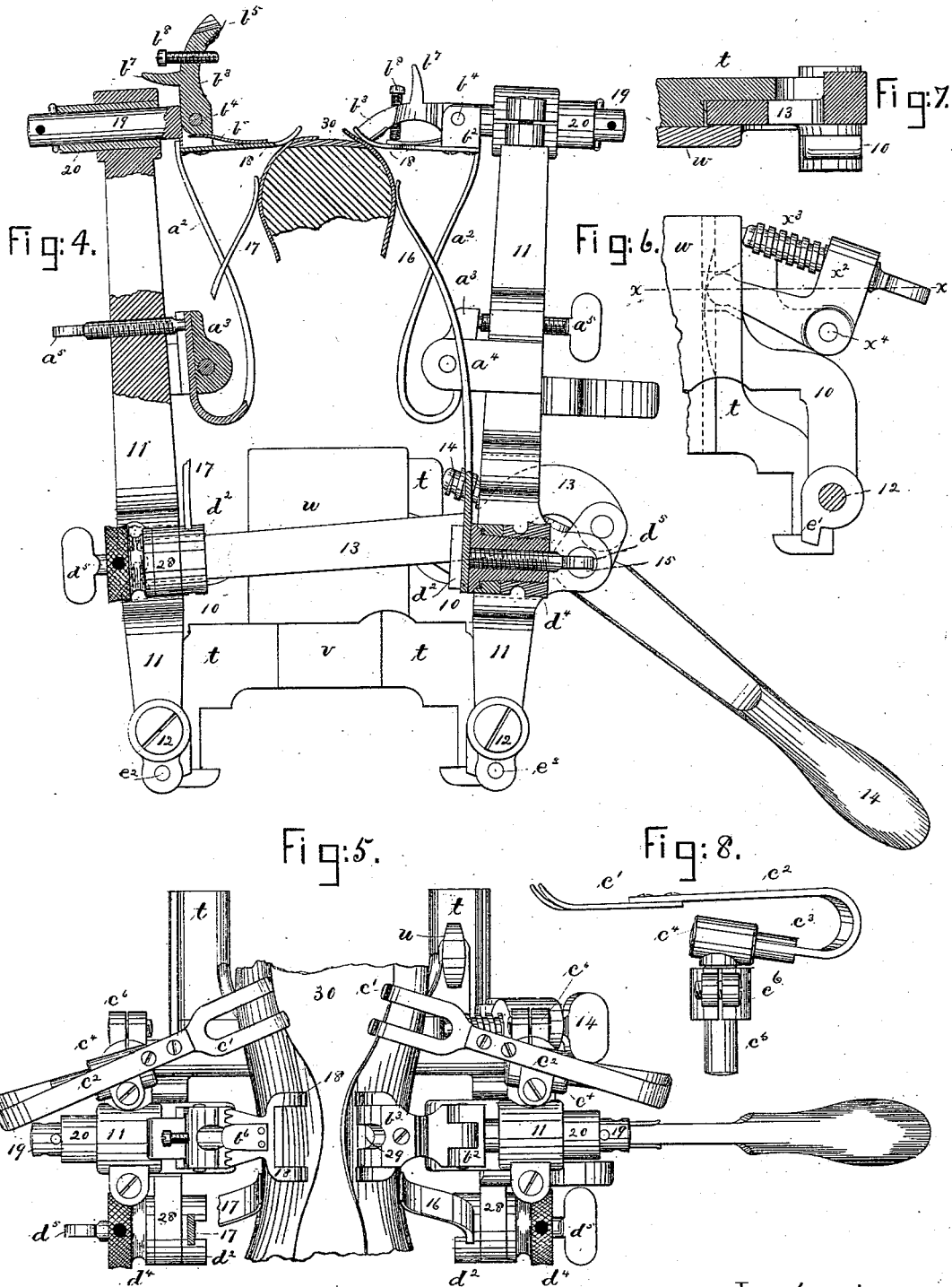

Witnesses.
N. E. Whitney
L. C. Cannon

Inventor.
Henry G. Thompson
by Crosby & Gregory Attys.

UNITED STATES PATENT OFFICE.

HENRY G. THOMPSON, OF MILFORD, CONNECTICUT, ASSIGNOR TO HIMSELF,
AS TRUSTEE FOR THE MAGNETIC LASTING MACHINE ASSOCIATION.

IMPROVEMENT IN LASTING MECHANISMS FOR BOOTS AND SHOES.

Specification forming part of Letters Patent No. 208,127, dated September 17, 1878; application filed April 15, 1878.

To all whom it may concern:

Be it known that I, HENRY G. THOMPSON, of Milford, county of New Haven, State of Connecticut, have invented an Improvement in Lasting Mechanisms for Boots and Shoes, of which the following is a specification:

This invention relates to mechanism for lasting boots and shoes.

In another application for patent for lasting-machine filed by me in the United States Patent Office November 6, 1877, and allowed, I have shown lasting mechanism upon which this is intended as an improvement. That application shows pivoted arms, made vertically and horizontally adjustable upon the head which carries the toe and heel lasting devices employing crimping-jaws or pullers to close the upper over the inner sole at the toe and heel of the shoe, such head being adapted to be supported at the upper end of a jack-rod properly counterbalanced, as represented in United States Letters Patent No. 193,446 and No. 193,445. These pivoted arms referred to in the application before cited carry fingers, which act to press the upper over the inner sole at the shank of the shoe.

In this my present application such fingers are dispensed with, and shank-pullers having teeth are employed to enter the edges of the upper, and positively pull and draw the upper at the shank about the last. These pullers are pivoted upon vibrating arms, which are moved by suitable levers toward and from the last, pressers also moving with them, crowding the upper over upon the edge of the inner sole before the pullers are thrown down, so that their teeth engage the upper, and then as the arms are further closed the pullers and arms rise somewhat, owing to the curved forward ends of the pressers, thereby exerting a combined upward and horizontal pull on the upper, which draws it snugly about the last.

Other specific features of invention will be hereinafter set forth in the claims.

Figure 1 represents a side elevation of the improved shank-lasting devices mounted upon the head, and also toe-lasting devices; Figs. 2 and 3, detail of the crimping-jaws and the device which holds them in place. Fig. 4 repre-

sents, in side elevation and partly in section, the arms, their carrying-frame, and shank-pullers and presser removed from the head; Fig. 5, a top view thereof; Figs. 6 and 7, details of the adjusting devices for setting the shank-pullers at the proper level; and Fig. 8, one of the auxiliary pressers detached.

The drawings, Fig. 1, show one-half the lasting-head and the toe-lasting devices, the crimping-jaws to operate upon the heel of the shoe being omitted as unnecessary to be shown, because they are in construction and operation like the toe-lasting devices.

The socket *a*, the pivoted supporting-plate *b*, the crimping-jaws *c*, and the lever *d*, and its connections to move the jaws forward and open and close them are as in United States Patent No. 193,446.

The carriage *e* (shown in dotted lines) is provided with a post, *f*, fitted to slide in ways *g* formed in the head *h*, and is made longitudinally adjustable in the head by means of a screw, *i*, provided with a thumb-nut, *j*, in order to adapt the jaws to shoes of different lengths.

The supporting-plate *b*, instead of being pivoted at its rear end, as in the patent cited, is pivoted at or near its forward end at *k* to the vertically-adjustable plate-carrying slide *l*, fitted to be raised and lowered with reference to the post *f*, by which it is guided.

The screw *m*, operating upon the rear end of the plate *b*, places the under sides of the crimping-jaws *c* at the proper inclination with reference to the toe or heel of the last, according to its curvature.

The plate-carrying slide *l* is provided with screw-threads to receive a screw, *n*, held in a sleeve, *o*, provided with a thumb-nut, *p*, by which the supporting-plate *b* and jaws may be quickly adjusted in height to place the jaws on the proper level with relation to the bottom of the last.

The slide-adjusting lever *q*—a crooked lever pivoted at *r*—has its short arm 2 connected by a small link, 3, with the slide at 4, so as to move it and the jaws vertically, to lift them above or force them down upon the shoe being lasted with more or less force. The handle or long

end of this lever g is provided with part of the locking device. This locking device, in this instance, is composed of a rod, 5, a spring, 6, to lift the rod, a pawl, 7, arranged to have its operating end lifted by depressing the rod, and a rack, 8, having teeth to be engaged by the pawl to lock and hold the handle and the slide and jaws in position.

The shank-lasting devices are carried by the frame t , made movable laterally on the guideway g of the head h , a set-screw, u , fastening the same. The vertical portion of the frame t is provided with a guiding-ledge, v , to which is fitted the finger-carrying slide w , having ears 10, to which are pivoted the arms 11, which carry the shank-lasting devices, such arms being pivoted to ears 10 by bolts 12, such arms being adapted to be passed from the outside of the last horizontally, or nearly so, across the edge of the last, toward the central line of the last's bottom.

One arm, 11, has pivoted to it one end of a link, 13, and the opposite end of such link is connected with the short end of a hand-lever, 14, pivoted at 15. The arms 11 are also provided with upper-pressing springs 16 17, to meet the side of the upper, press it firmly against the side of the last, and place the upper in proper condition to be operated upon by the shank-lasting devices, which crowd the upper over the last as the arms are closed.

An adjusting device, shown in this instance as composed of an elbow-lever, x^2 , and a thumb-screw, x^3 , is pivoted at x^4 to the frame t . The long end of such adjusting-lever enters a notch at one edge of the slide w , (see dotted lines, Fig. 6,) and as the screw x^3 is turned into the lever, its end, acting against the fixed part t , causes its other end to lift the slide w and its attached arms 11 to place the main pressers 18 in such position with reference to the bottom of the last that they, when closed toward the shoe, will meet the upper at the edge of the last and crowd the upper at the shank over upon the last.

The ends of the pressers are rounded, so that as they are closed upon the upper and passed beyond the last's edges they will be lifted, carrying with them the arms, slide w , and pressers.

These main pressers, located at the narrowest portion of the shank, are attached to slides 19, fitted in sleeves 20, adjustably held at the upper ends of arms 11. Springs a^2 , attached to blocks a^3 , pivoted upon lugs a^4 of arms 11, bear against the shoulders b^2 of the main pressers to hold them forward in the sleeves, the force with which they are held forward being regulated by the screws a^5 . The stress of the springs a^2 is made adjustable in this way to regulate the amount of strain to be put upon the upper as it is drawn over and about the last by the shank-pullers b^3 , pivoted at b^4 , and provided with teeth b^5 , to penetrate the upper when the pullers are turned down, as at the right of Fig. 4, to engage the upper,

which is done each time that the main pressers close upon the last far enough for their rounded ends to get a start over the last's edge.

The puller at the left of Fig. 4 is shown elevated and in section to illustrate the action of the spring b^6 , which holds the puller up out of operation, or down, so as to engage the upper.

Just before presser 18 arrives at the position indicated at the right of Fig. 4 the pullers are thrown down so that their teeth penetrate the upper between the points of the presser; (see Fig. 5,) and thereafter further inward movement of the arms 11 by the handle 14 causes the arms 11 and slide w to rise as the pressers pass over upon the inner sole; and as such arms, pressers, and pullers so rise, the last being held down at the toe and heel by the crimping-jaws, the upper, engaged by the teeth of the pullers, is pulled by an upward strain closely about the last, and the edge of the upper is carried positively over upon the inner sole, to be secured by suitable nails or fastenings driven in any usual way.

The screw x^3 of the adjusting-lever x^2 is made to bear loosely against t , so that the arms 11 and slide w may be free to be lifted, as just described. This positive upward pull or strain of the pullers exerted upon the upper at the shank is a most important feature of this invention, for, by reason thereof, the shank may be lasted perfectly tight, the action being substantially that of a workman with pinchers.

It will be obvious, by drawing the upper upward about the last by a puller having a combined vertical and horizontal movement, that the principal portion of the strain upon the upper will be exerted to stretch it by a direct pull from the top of the instep of the last to the edge of the sole; whereas, if the puller had only a horizontal movement, much of the strain would be lost in friction of the upper against the sides and corners of the last. At the time that these jaws are being closed and raised the operator is pressing downward upon the lever-handle 14; and it will be noticed that such downward force exerted by him is made to exert additional upward strain on the pressers, for, the last being fixed, the pullers, pressers, and arms are raised by the downward thrust on the handle 14.

The finger-pieces b^7 permit the pullers to be easily lifted, and the screws b^8 regulate the distance at which the teeth shall penetrate the upper.

The slides 19 of the pressers are free to oscillate in the sockets at the tops of arms 11. The auxiliary pressers c^1 , placed at the sides of the main pressers, are attached to springs c^2 , held securely to stems c^3 , fitted into the tubular adjustable heads c^4 at the upper ends of pins c^5 , held in sockets c^6 , projecting from arms 11.

The upper-pressing springs 16 17 are fitted into grooves in the heads of spring-holders d^2 ,

made as tubular bolts, externally screw-threaded, (see sectional view, Fig. 4,) extended through ears 28 of arms 11, where they receive milled nuts d^4 , which confine the holders d^2 in such adjustable position that the springs may project upward with the desired inclination toward the toe or heel of the last.

Bolts d^5 , extended through the holders d^2 , bear upon the faces of the lower ends of the springs and hold them in adjusted position vertically.

The ears 10 are provided with stops e^1 , (see Fig. 6,) against which pins e^2 at the lower ends of arms 11 strike when the arms are thrown fully apart.

The pullers are provided each with an opening, 29, for the passage of a tack or nail into the upper and inner sole, 30, while the upper is held by pullers.

The distance that the puller b^3 may move forward from the arms 11 may be controlled by adjusting the sleeves 20 horizontally.

A patent granted to me, No. 193,466, July 24, 1877, shows and describes a shank-lasting device adapted to be connected with the upright frame of a tack-driving machine, and it has a presser and pins to enter the upper. In that patent the pins were thrown down to engage the upper by the backward movement of a slide-rod.

In this my present invention the shank-laster is to be carried on a jack pivoted as in the United Patent No. 193,446.

In Patent No. 193,466 the shoe was pressed backward against the shank-lasting device; but in this invention the shank-lasting devices are moved horizontally toward the fixed shoe at each side thereof. These pullers are thrown down into engagement with the upper by hand, and their time of engagement is thus controlled according to the requirements of the shoe being lasted.

The devices shown in top and side view, Fig. 3, hold the crimping-jaws c upon their sliding fulcrum-pin 21, the pin 24 entering a slot therein, as described in my other application.

The pulling device and presser may be used to advantage by moving them by means of a sliding or reciprocating carrier, rather than by a vibrating arm; but the latter is preferable.

I claim—

1. In a lasting-machine for boots and shoes, the main presser and toothed puller to engage the upper, combined with an arm to move the puller toward the center of the last, substantially as described.

2. The puller-carrying arm and toothed puller to engage the upper, combined with a spring to press the puller forward, in order that the puller may yield backward as the arm moves the puller toward the center of the last, substantially as described.

3. The toothed puller, its carrying-arm, and spring to hold the puller forward with a yield-

ing pressure, combined with mechanism to adjust the force of the spring to regulate the amount of strain upon the upper, substantially as described.

4. In a lasting-machine, the toothed upper engaging device, its rod, and carrying-arm, combined with the adjustable sleeve to govern the forward position of the puller, substantially as described.

5. The main presser and toothed puller pivoted thereon to engage the upper, combined with a spring to hold the puller in elevated position until thrown down by hand to engage the upper, substantially as described.

6. The carrying-arm and main presser, combined with the pivoted puller and its adjusting-screw, to regulate the distance to which the teeth of the puller may descend below the presser, substantially as described.

7. The movable arms 11 and the main pressers and pullers, combined with the auxiliary pressers having spring-shanks.

8. The side-pressing spring, combined with the arm, by means of the holder and bolt, to permit the vertical and horizontal adjustment of the acting end of the spring.

9. The frame t , provided with a guideway for the slide w , and the adjusting device pivoted thereon, combined with the slide w , arms and toothed pullers, and main pressers, the adjusting device being adapted to place the pressers at the desired level with reference to the last, and to permit the arms, pressers, and slide to rise as the pressers pass upon the last, substantially as described.

10. In a lasting-machine, the arms, main pressers, rounded at their forward ends, and toothed pullers located at each side the last opposite the shank of the shoe, combined with mechanism to support the pressers at the proper level with reference to the edge of the stationary last and inner sole, as described, and devices to move the main pressers and toothed pullers toward the center of the last, whereby the pulleys and arms during such movement are also moved vertically with reference to the last, to stretch and fit the upper about the last, substantially as described.

11. In a lasting-machine having adjustable toe and heel crimping jaws to press the edges of the upper horizontally over upon the last-bottom, shank-lasting mechanism, composed of arms provided with main pressers, toothed pullers, and springs to hold the pressers and pullers forward, such pressers, pullers, and arms being constructed and operated to engage the upper, and while engaged therewith move upward and horizontally with reference to the bottom of the last, substantially as described.

12. The frame t and slide w , carrying the shank-lasting devices, combined with an adjusting device to regulate the level of the main pressers as they commence to move forward, the connection between the adjusting device, frame, and slide being adapted to permit free

vertical movement of the slide and pressers as the latter are closed over the last-bottom, substantially as described.

13. The toothed puller, hinged at the rear end, and provided with a thumb-piece to lift it and a screw to regulate its descent, combined with the presser provided at its front end with an open space for the puller-teeth to enter the upper, substantially as described.

In testimony whereof I have signed my name to this specification in the presence of two subscribing witnesses.

HENRY G. THOMPSON.

Witnesses:

H. GRANT THOMPSON,
SAML. E. MOWER.