

W. W. KRUTSCH.
Stirrup Planing-Machine.

No. 208,183.

Patented Sept. 17, 1878.

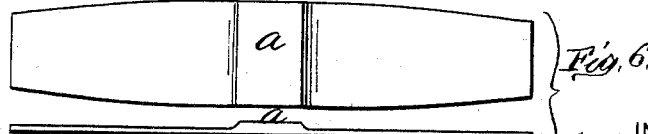
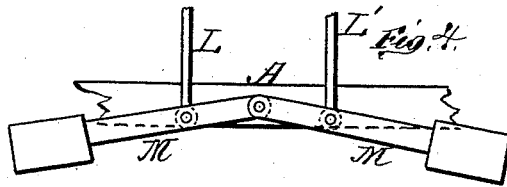
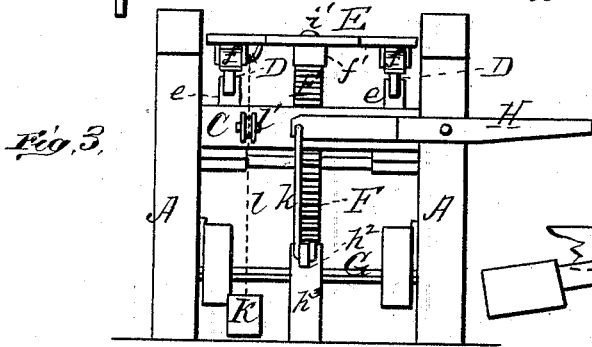
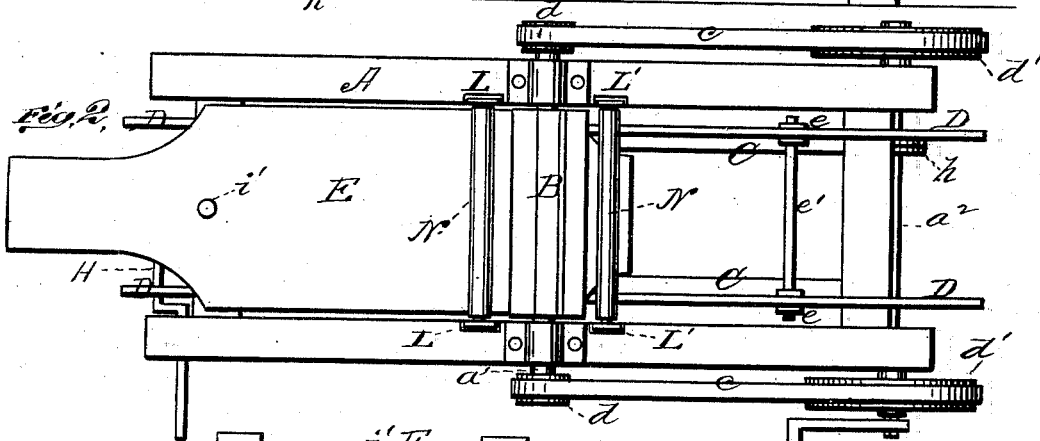
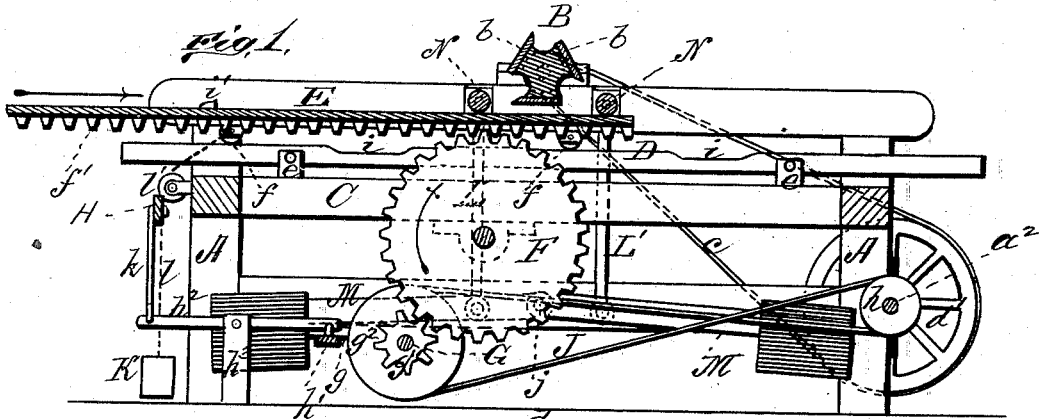

WITNESSES
E. H. Bates
J. J. Masi

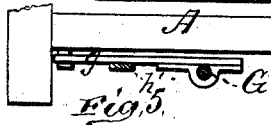

INVENTOR
W. W. Krutsch,
By E. W. Anderson.

ATTORNEY

UNITED STATES PATENT OFFICE.

WILLIS W. KRUTSCH, OF DELPHOS, OHIO.

IMPROVEMENT IN STIRRUP-PLANING MACHINES.

Specification forming part of Letters Patent No. **208,183**, dated September 17, 1878; application filed March 2, 1878.

To all whom it may concern:

Be it known that I, WILLIS W. KRUTSCH, of Delphos, in the county of Van Wert and State of Ohio, have invented a new and valuable Improvement in Stirrup-Planing Machines; and I do hereby declare that the following is a full, clear, and exact description of the construction and operation of the same, reference being had to the annexed drawings, making a part of this specification, and to the letters and figures of reference marked thereon.

Figure 1 of the drawings is a representation of a longitudinal vertical section of my invention. Fig. 2 is a top view thereof. Fig. 3 is an end view of the same; and Figs. 4, 5, and 6 are details.

This invention has relation to improvements in machines for planing wooden stirrup-blanks and putting them into shape for bending.

The nature of the invention will be fully understood from the following description:

In Fig. 6 of the drawings is shown the stirrup-blank, having at its central part a raised portion, *a*, upon which the ball of the foot rests when the stirrup is in use.

The object of my invention is to produce a planing-machine which will accurately produce this shape of stirrup-blank.

In the annexed drawings, the letter A designates an upright frame, affording bearings at its upper edge to a rotary cutter, B, having suitable blades *b*. The cutter B is driven by means of endless belts *c* passing around pulleys *d* *d'*, respectively, on the ends of the cutter-shaft *a*¹ and the main driving-shaft *a*² at the end of the frame.

C represents a strong horizontally-arranged frame, secured to the main frame A, and provided with upright forked standards *e* at suitable distances apart, to which are removably secured, by means of tie-rods *e'* or their equivalents, the track-rails D, having upon their upper edges, inside of the standards *e*, the depressions *i*. Upon these rails is mounted a table, E, having grooved traveler-wheels *f*, and provided upon its under side with a longitudinal rack, *f'*, that engages a large gear-wheel, F, having its bearings upon the under side of the frame C. The table has free end-

wise motion under the cutter between the sides of the frame.

G represents a shaft having its bearings in the vertically-vibrating arms *g* upon the under side of the frame, and provided with a gear, *g*¹, and a pulley, *g*², in line with a pulley, *h*, upon the main driving-shaft aforesaid. The arms *g* are supported by a transverse bar, *h*¹, suspended from the weight end of a lever, *h*², having its bearings in an upright, *h*³, and operated to raise the arms *g* and engage the gear *g*¹ with the large gear F by means of a lever, H, and a connecting-rod, *k*, connecting it with the lever *h*². The pulleys *g*² and *h* are connected by an endless belt, J. By throwing up the power end of the lever H the gears *g*¹ and F are engaged and the table moved endwise under the cutter.

The stirrup-strip is a plane piece of wood, and is placed upon the table with its end against a stop, *i'*, which may be adjustable to or from the cutter. The gears *g*¹ and F are engaged, and the table is moved under the cutter, which then planes off the strip upon a level until the wheels drop simultaneously into the depressions of the rails D, which lowers the strip to such an extent that its upper surface is barely touched by the plane-bits. The movement of the carriage continuing, it rises out of the depressions *i*, and the remaining end of the strip is cut out, thereby forming a blank with a raised central platform or bearing-surface, *a*, as shown in Fig. 6.

The blank being removed at the rear of the cutter-table, the lever H is thrust down, thereby disengaging the gears *g*¹ and F, and the table is run back by a weight, K, suspended from its under side by a cord, *l*, working over pulleys *l'*.

L L' represent vertical rods arranged in guides upon the insides of the sides of the frame, and connected at their lower ends to vertically-vibrating weighted levers M, having their fulcrums on the frame at *j*. These rods afford bearings at their upper ends to the rollers N, below which the stirrup-strip on the carriage passes, and by means of which it is held thereon with sufficient force to prevent slipping. One of these rollers is at each side of the cutter, and the rear one readily rises

horizontally to permit the passage of the part *a* of the blank, and, after its passage, adjusts itself to the conformation of the said blank automatically.

The standards *e*, which support the rails, are readily adjustable with reference to the frame C, so as to raise or lower the table according to the thickness of the stirrup-blank sought to be produced.

What I claim as new, and desire to secure by Letters Patent, is—

1. In a machine for cutting wooden stirrup-blanks, the combination, with a rotary cutter and a table moving under the same and provided with transporting-wheels, of a track, D D, having the depressions *i*, as and for the purpose specified.

2. The combination, with a rotary cutter, B, and endwise-movable table E, having a rack, *f'*, upon its under side and a suspended weight, K, and a gear-wheel, F, engaging said rack, of a gear, *g'*, adapted to be disengaged from the said gear F by means of a lever, H, substantially as specified.

In testimony that I claim the above I have hereunto subscribed my name in the presence of two witnesses.

WILLIS W. KRUTSCH.

Witnesses:

B. J. BROTHERTON,
M. V. LONGSWORTH.