

G. S. ROBERTS.
Molding-Machine and Wood Molding.

No. 208,202.

Patented Sept. 17, 1878.

Fig. 1.

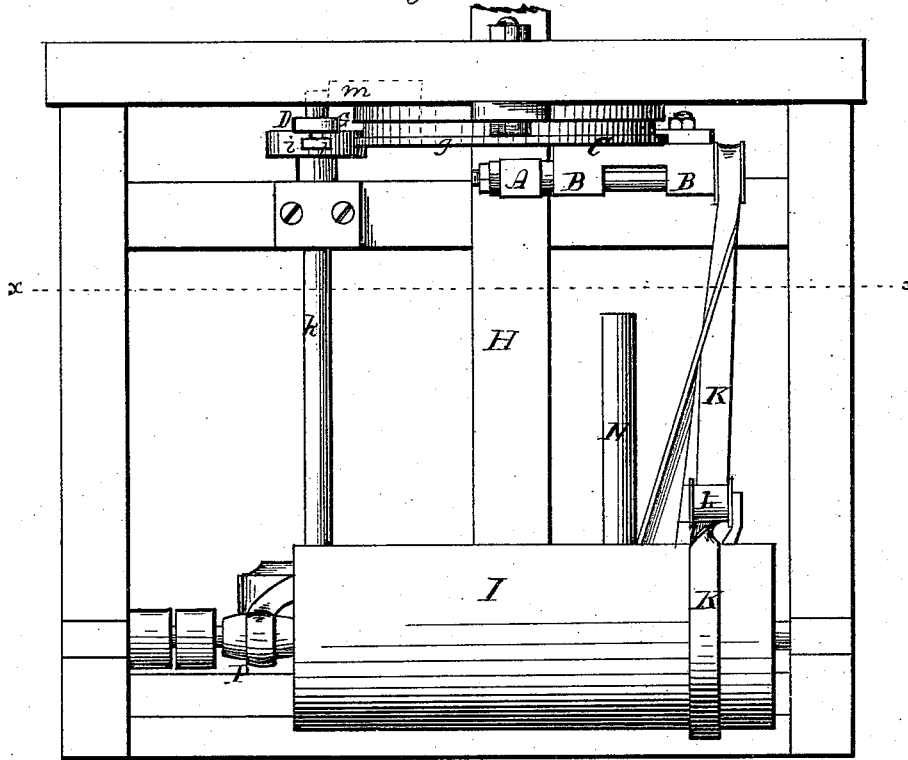
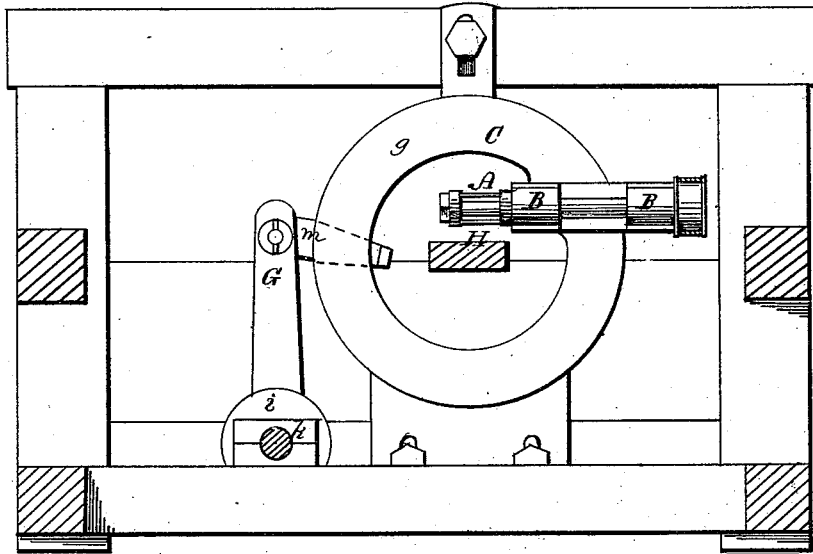

Fig. 2.



WITNESSES

E. W. Sallaber,
D. Plow

INVENTOR,

George S. Roberts,
By J. S. Brown,
his ATTORNEY.

G. S. ROBERTS.
Molding-Machine and Wood Molding.

No. 208,202.

Fig. Patented Sept. 17, 1878.

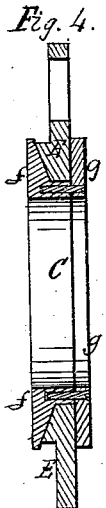
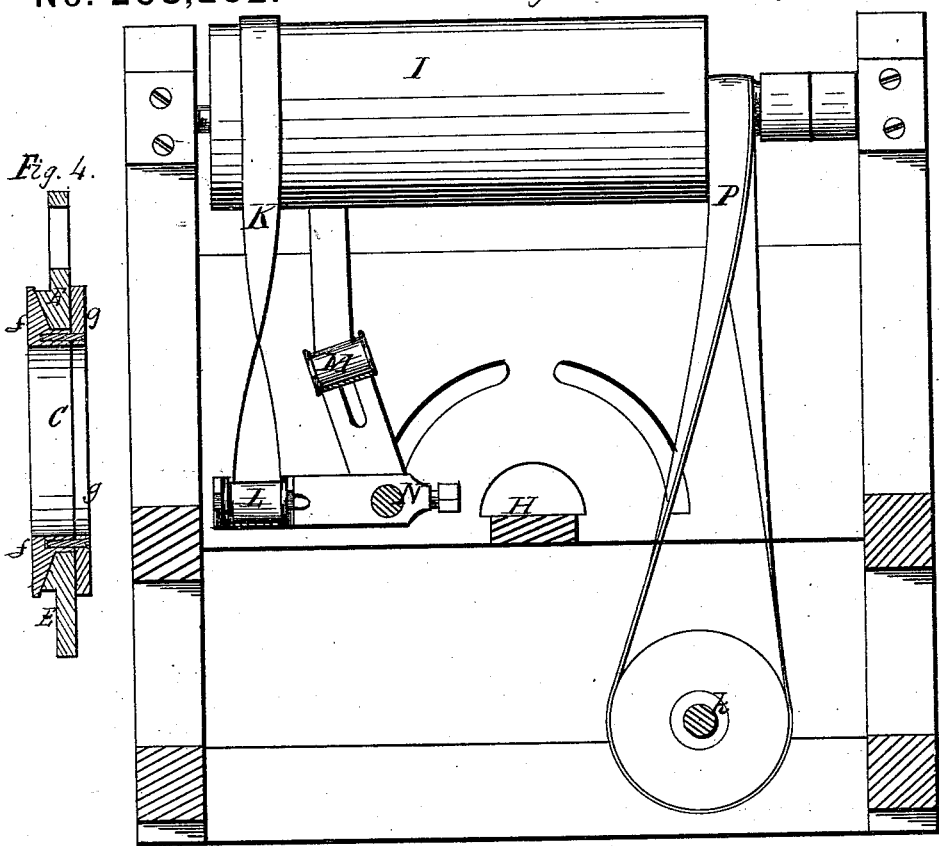
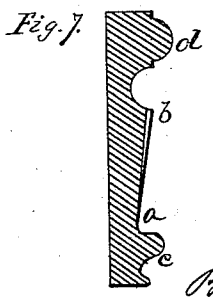
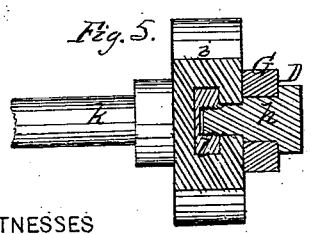
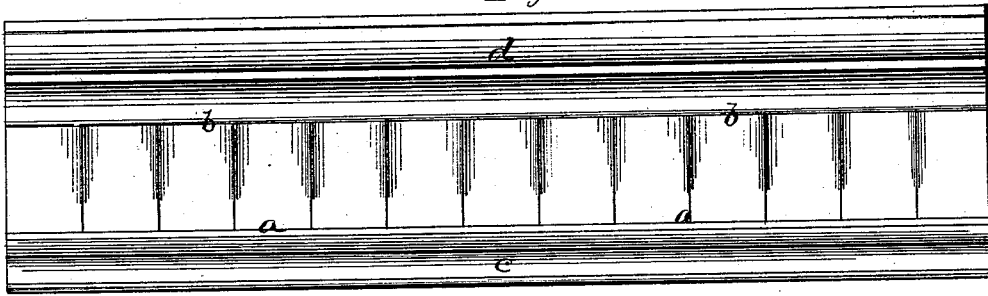

Fig. 6.



WITNESSES
C. McCallahan,
D. P. Rowl.

INVENTOR,
George S. Roberts,
By J. S. Brown,
his ATTORNEY.

UNITED STATES PATENT OFFICE.

GEORGE S. ROBERTS, OF MEREDITH, NEW HAMPSHIRE.

IMPROVEMENT IN MOLDING-MACHINES AND WOOD MOLDINGS.

Specification forming part of Letters Patent No. 208,202, dated September 17, 1878; application filed July 21, 1877.

To all whom it may concern:

Be it known that I, GEORGE S. ROBERTS, of Meredith, in the county of Belknap and State of New Hampshire, have invented an Improved Wood Molding and Machine for Manufacturing the same and other Moldings; and I do hereby declare that the following is a full and exact description thereof, reference being had to the accompanying drawings, making part of this specification—

Figure 1 being a top view of the machine for manufacturing the improved molding; Fig. 2, a vertical section thereof in a plane indicated by the line *xx*, Fig. 1, looking toward the front of the machine; Fig. 3, a vertical section in the same plane, looking toward the rear of the machine; Fig. 4, a central section of one of the parts of the machine; Fig. 5, a view of another part detached; Figs. 6 and 7, views of one style of the improved molding.

Like letters designate corresponding parts in all of the figures.

My improvement in the molding consists in forming a wave thereon, the undulations of which are deeper at one side of the molding or edge of the part so ornamented than at the other edge, generally the undulations running out, or nearly so, into a plane, as at *a*, Figs. 6 and 7, while at the opposite edge, *b*, of the band on which the wave is cut the undulations are cut deepest. This wave may extend the whole width of the molding, but preferably and generally it covers only the middle portion or frieze thereof, as shown, while there are straight portions *c d* at the two edges, forming, respectively, the architrave and cornice of a complete order; also, the line of the wave may be straight, as shown, or of any figured outline, so as to produce a great variety of form to suit various tastes or effect varied designs; and the molding itself may be straight or curved, as may be required.

For the production especially of this class of peculiar wave-molding I have invented an improved mechanism, which is embodied in the machine represented in the accompanying drawings and constructed and operating substantially as follows: The essential feature of this machine consists in a revolving cutter, the bearings of which have a vibratory motion, one

greater than the other, while the cutter is acting on the molding. To produce this vibratory motion of the cutter, I attach its bearings to a ring or circular rim, which has a regular vibratory motion around its axis communicated to it by means of a crank or its equivalent.

In the drawings, the cutter *A* is represented as mounted in bearings *BB*, which are attached to a ring, *C*, having a vibratory motion communicated to it, around its center or axis, by means of a crank, *D*. To adjust this vibratory ring to have the proper movement without introducing a hub or spokes, so that the central part may be free for the passage of the molding to be cut, I mount it on another ring, *E*, which is attached to the frame, as shown in the drawings.

For convenience of manufacture and accuracy of movement I construct the movable ring *C* in two parts, *f g*, one fitting the front and the other the back of the stationary ring, which is preferably chamfered toward the center, so that the two parts *f g* may meet inside thereof and be bolted together as one, all as shown in Fig. 4.

The crank or eccentric *D* consists of a crank-pin, *h*, secured in a cross-groove of a disk, *i*, on a revolving shaft, *k*, as shown in Fig. 5, the crank-pin being adjustable to any desired distance from the center of motion, and held in position by a set-screw, *l*, whereby any desired extent of motion may be given to the connecting-rod *G*, which connects the crank with the vibratory ring, there being a suitable eye or projection, *m*, on the ring to which the connecting-rod is jointed.

The cutter *A* is arranged so that its inner extremity reaches just to the center of the ring when the wave is desired to run out or not be formed at one edge of the molding, whereby, obviously, no vibration takes place there, while the other extremity of the cutter, being nearest to the periphery of the ring, has the greatest movement and cuts the wave the deepest. The bearings of the cutter being adjustable toward and from the center of the ring, any desired depth of wave at either edge is thereby enabled to be cut.

The molding or strip to be finished with the wave or figure is fed along through the ring

under the cutter, being so gaged as to bring one edge or any line thereof at the center of the ring, where the vibration is nothing. The molding-piece may be run under the cutter near the periphery of the vibratory ring only, in which case, instead of a simple wave molding, the molding will be cut into at intervals, producing a variety of forms, according to adjustment and shape of cutter. Thus the machine is capable of various effects.

The strip may be fed along by hand; but for greater accuracy and ease it may be fed along automatically by any of the well-known means, such as feed-rollers or a feed-cylinder or endless apron with holding-points. It is moved upon a suitable way or bed, H, which may be adjustable up and down to accommodate different thicknesses of molding; but I provide for the same purpose by adjusting the stationary ring E up and down on the frame.

Motion is communicated to the revolving cutter from a suitable drum or pulley, I, on the driving-shaft by a belt, K, which passes around two binder-pulleys, L M, so situated that they guide the belt in the right direction and allow the cutter-pulley to move up and down by the vibrations of the cutter-shaft. Both of these binder-pulleys are adjustable by their bearings longitudinally and radially on a stationary shaft or rod, N, which also is adjustable laterally in position in a curved or other slot, *p*, of the frame, as shown, or otherwise. Suitable motion also is communicated to the crank-shaft *k* from the driving-shaft by a belt, P.

What I claim as my invention, and desire to secure by Letters Patent, is—

1. A wave wood molding having its undulations deeper at one edge than at the other, substantially as and for the purpose herein specified.

2. In a wood molding, the combination of a waved frieze with a straight architrave and cornice completing the order, substantially as and for the purpose herein specified.

3. In a machine for cutting moldings, the combination of a vibratory ring, C, bearing a rotating cutter, and constructed in parts *f g*, as described, with a stationary ring, E, substantially as and for the purpose herein specified.

4. In a machine for cutting moldings, a rotating cutter, A, mounted on a ring, C, which has a vibratory motion around its axis or center, substantially as and for the purpose herein specified.

5. In a machine for cutting moldings, the combination of a vibratory ring, C, bearing a cutter, A, with a crank, D, and connecting-rod G, substantially as and for the purpose herein specified.

6. In a machine for cutting moldings, the combination of a vibratory cutter, A, driving-belt K, and adjustable binder-pulleys L M, substantially as and for the purpose herein specified.

GEO. S. ROBERTS.

Witnesses:

J. P. MILLER,
D. S. STIMSON.