

F. S. SHIRLEY.  
Tempering Glass.

No. 208,207.

Patented Sept. 17, 1878.

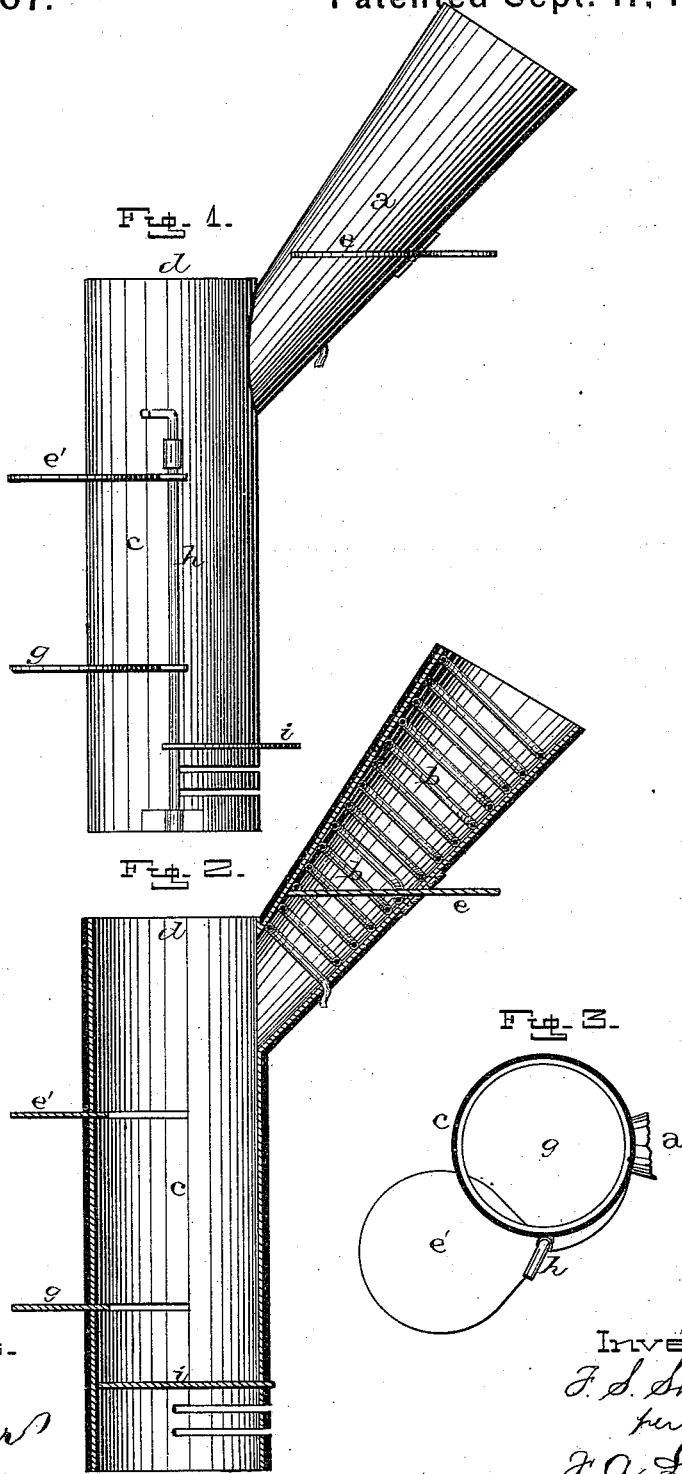

Witnesses.

*J. W. Garner*  
*W. S. D. Haines*

Inventor  
*F. S. Shirley*  
per  
*J. A. Lehmann*  
att'y

F. S. SHIRLEY.  
Tempering Glass.

No. 208,207.

Patented Sept. 17, 1878.

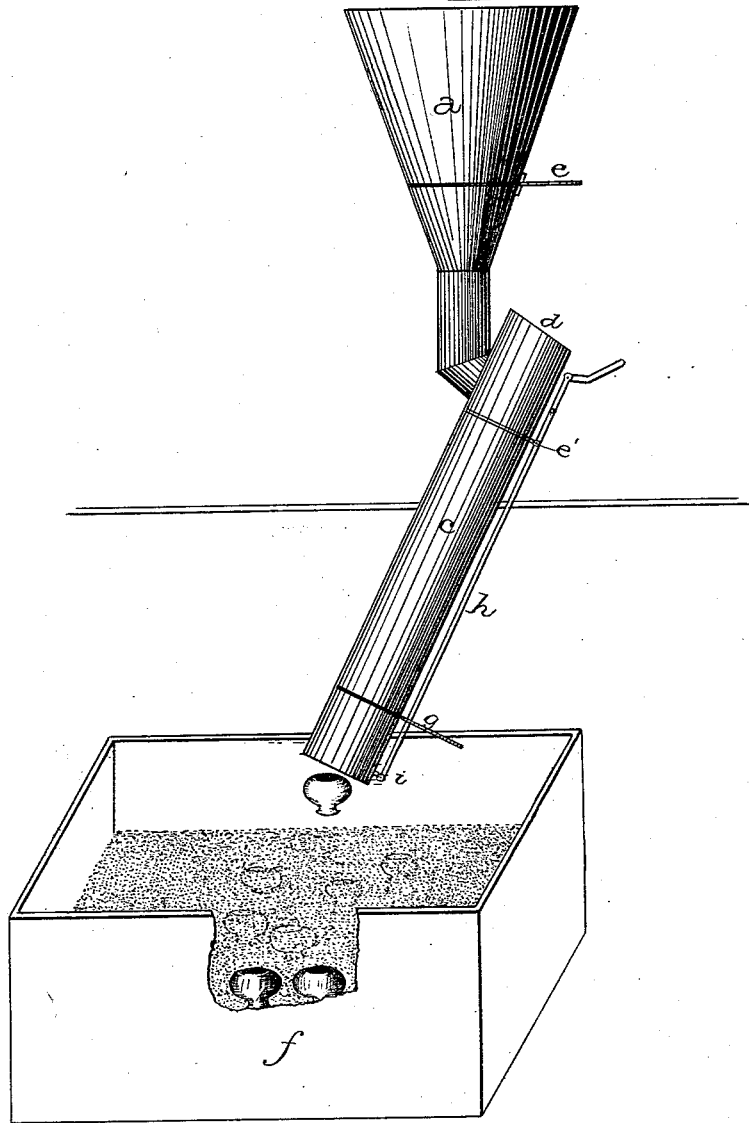

Witnesses:

*J. W. Garner*  
*W. S. D. Garner*

Inventor:

*F. S. Shirley*  
per  
*F. A. Lehmann,*  
Atty.

# UNITED STATES PATENT OFFICE.

FREDERICK S. SHIRLEY, OF NEW BEDFORD, MASSACHUSETTS.

## IMPROVEMENT IN TEMPERING GLASS.

Specification forming part of Letters Patent No. 208,207, dated September 17, 1878; application filed May 29, 1878.

*To all whom it may concern:*

Be it known that I, FREDERICK S. SHIRLEY, of New Bedford, in the county of Bristol and State of Massachusetts, have invented certain new and useful Improvements in Tempering Glass; and I do hereby declare the following to be a full, clear, and exact description of the invention, such as will enable others skilled in the art to which it pertains to make and use it, reference being had to the accompanying drawings, which form part of this specification.

My invention relates to an improvement in tempering glassware; and it consists, first, in enveloping articles of glassware, while still hot from the furnace, in tempering compounds, which will temporarily retain the heat, prevent irregular contraction, and thus effect a great gain in strength and evenness of temper at a great reduction of cost over the old annealing process; second, in the construction of simple and inexpensive mechanism for the use and operation of my process, as will be more fully described hereinafter.

Figure 1 is a side elevation of the mechanism used by me in carrying out my process. Fig. 2 is a vertical section of the same. Fig. 3 is a detail view; and Fig. 4 is also a vertical section, showing the chute placed at an angle.

*a* represents the hopper, which is to receive the tempering compound and which has a coil of steam-pipe, *b*, arranged around its interior to heat the compound, and is incased in felt or any non-conducting material, so as to prevent the radiation of heat. Moving in and out through a slot in the side of the hopper is a valve, *e*, which serves to control the flow of the tempering compound from the hopper into the chute. This valve may either be operated by hand or may be connected to the other valves by means of any suitable mechanism, so as to move at the same time they do.

This hopper opens into the chute *c* at any suitable distance below its mouth *d*, which chute may extend vertically through the floor or at any suitable angle, so that its lower end will open just over the top of a box or receptacle placed there to receive the contents of the chute. This chute may also be incased in any non-conducting material, if so desired, but this is not necessary. Pivoted

upon the side of the chute is the lever *h*, which has the three valves *e' g i* secured to it, so as to move with it. The upper valve, *e'*, is placed at a suitable distance below the mouth of the hopper, so as to receive the articles of glassware, while still glowing hot, from the end of the "post."

The second valve, *g*, is placed lower down in the chute, moves at the same time with the valve *e'*, and in the same direction. This valve serves to prevent the articles from dropping down too far when the upper valve is operated.

The third valve, *i*, is secured to the lever *h* at a slight distance below the one *g*, and moves in an opposite direction from the two upper ones, though it moves at the same time with them. When the two upper ones open this one closes, and vice versa.

The valve *i* is adjustably connected to the lever, so that it can be adjusted up and down thereon to fit in the slots made in the lower end of the chute for that purpose, so as to increase or decrease the distance between it and the valve *g*, according to the size of the articles passing through the chute.

This apparatus should preferably be located near the "gaffer," or glass-finisher, and any number of them may be used suited to the size of the glass-works in which they are situated.

The method of operating this device may be described as follows: The chute *c* having been filled with the tempering material hereinafter described, the operator places quickly in its mouth the glass article, still glowing hot, and just detached from the iron tube or "post." Lever *h* is then pulled out, whereupon valve *e* opens, discharging a quantity of the heated compound on and around the said article. As it sinks below valves *e' g*, after the lever has been operated a number of times, valve *i* opens and lets out into chamber *f* the lowermost article in the chute with its surrounding compound, while valves *e' g* close, to prevent more than one article passing at a time.

Any necessary number of these machines may be used to accommodate the needs of the workmen; and the chutes may be of any desired size suited to the size of the articles to pass through them. They may also be so arranged that additional sections may be added

to them. A secondary chamber or receiver may also be added to continue the process after the goods have been discharged at the bottom of the first, this being a necessity in the case of heavy articles, which require to be cooled very slowly. The tempering material from the lower chamber can be elevated by proper machinery and thrown back into the hopper, as it can be used over again any number of times.

This apparatus may be varied, and so arranged as to adapt it thoroughly to each variety of glass manufacture.

The materials which I use for the tempering compound vary, and are used according to the character of the article to be tempered and the intensity of the heat to which the compound is to be subjected. Bran, meal, or sawdust, when rendered fire-proof by the action of tungstate of soda or other chemicals, asbestos, and other such materials as will form an air-tight packing around each article, and thus protect it from the air, will answer my purposes.

Each article of glassware should be removed as quickly as possible, while hot, from contact with the air, and the finely-powdered tempering compound is allowed to flow all over and around each one as soon as it is placed in the tube, so as to form a seal around it and retain its heat as long as possible.

The powdered compound should be of such a nature, if possible, that it can be used over and over again, and not be consumed by heat.

Either the end of the chute may be made to move back and forth over the box or chamber in which the articles of glassware are deposited or the box may be connected to a suitable mechanism, so that the box may be moved along a slight distance each time the valves are operated.

Having thus described my invention, I claim—

1. The process herein described of tempering and strengthening glassware, consisting in packing the articles, while hot, in a suitable material for retaining their heat and protecting them from the air, substantially as described.

2. The combination of a spout or hopper containing the tempering compound or material into which the article of glassware is placed and suitable valves, the parts being arranged to operate substantially as shown.

In testimony that I claim the foregoing I have hereunto set my hand this 4th day of April, 1877.

FRED. S. SHIRLEY.

Witnesses:

R. M. BARR,  
J. W. GARNER.