

H. LOMBARD.  
Whip-Rounding Machine.

No. 208,249.

Patented Sept. 24, 1878.

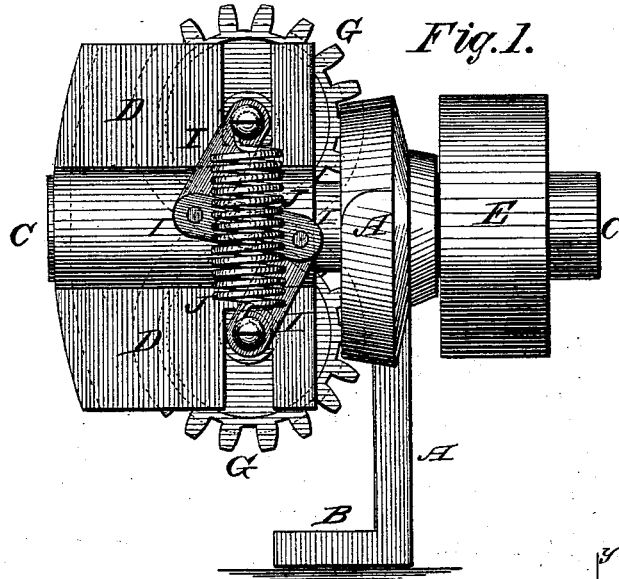

Fig. 1.

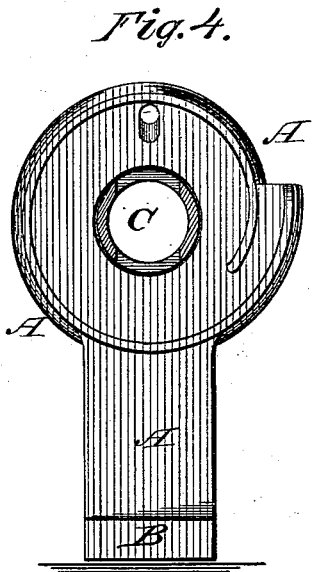

Fig. 4.

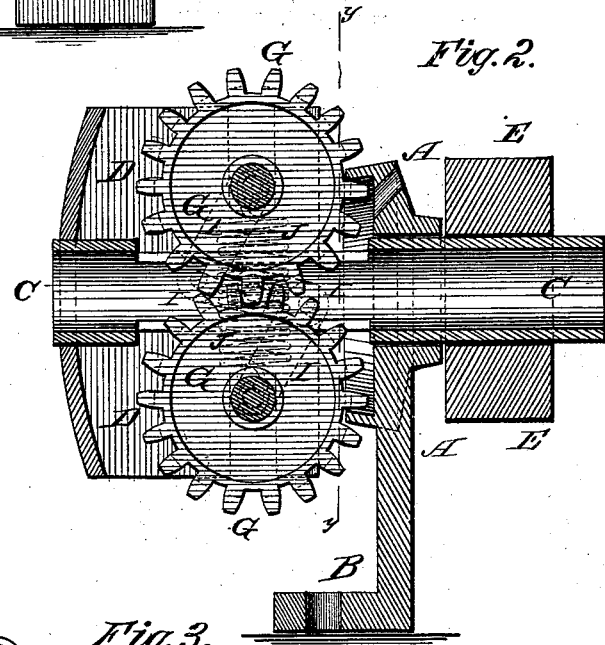

Fig. 2.

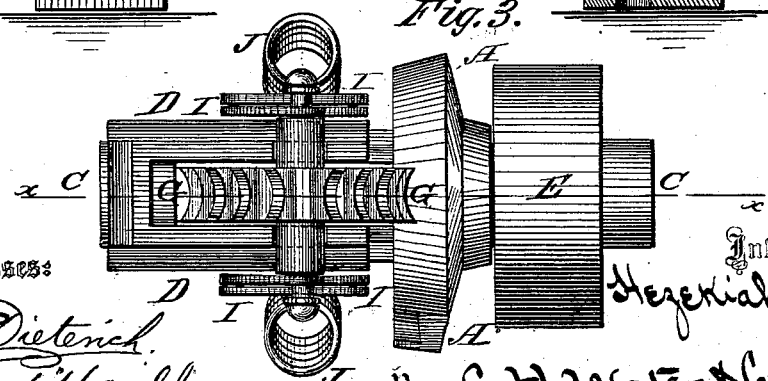

Fig. 3.

Witnesses:  
P. C. Dieterich.  
Frank H. Duffy

Inventor:  
Hezekiah Lombard.

Per: C. H. Watson & Co. Attorneys.

# UNITED STATES PATENT OFFICE.

HEZEKIAH LOMBARD, OF WESTFIELD, MASSACHUSETTS.

## IMPROVEMENT IN WHIP-ROUNDING MACHINES.

Specification forming part of Letters Patent No. **208,249**, dated September 24, 1878; application filed August 6, 1878.

*To all whom it may concern:*

Be it known that I, HEZEKIAH LOMBARD, of Westfield, in the county of Hampden and State of Massachusetts, have invented certain new and useful Improvements in Whip-Rounding Machines; and I do hereby declare that the following is a full, clear, and exact description thereof, which will enable others skilled in the art to which it appertains to make and use the same, reference being had to the accompanying drawings, and to the letters of reference marked thereon, which form a part of this specification.

My invention relates particularly to whip-rounding machines; and it consists in the construction and arrangement of a mechanism for rotating the whip and feeding it in the direction of its length, as will be hereinafter more fully set forth.

In the annexed drawings, Figure 1 is a side elevation. Fig. 2 is a central vertical section on line *x x*, Fig. 3. Fig. 3 is a plan view; and Fig. 4 is a transverse vertical section on line *y y*, Fig. 2.

A represents a scroll-cam, provided with foot B. Through this scroll is passed a hollow mandrel, C, on one end of which is fastened the driving-pulley E, and on the other end the sheath or head D. In this sheath are mounted two toothed rollers, G G, the journals of which pass through slots in the sides of the sheath, and have their bearings in the ends of toggle-levers I I, and the two journals on each side are connected by a spiral spring, J. The teeth of the rollers G' are made concave, as shown.

The foot B of the scroll-cam A is to be attached to the whip-rounding machine in such a manner that the center of the hollow mandrel will come in line with the face of the cutters, when the mandrel is made to revolve by means of the pulley E, carrying the sheath D and toothed wheels G around, and the teeth of the wheels, coming in contact with the scroll

A, causes them to rotate upon their own axis, thus drawing anything along which is placed between them, they being held together by the spiral springs J, and kept at equal distance from the center of rotation by means of the toggle-levers I I.

By placing one or more of these machines before the cutters of the whip-rolling machine to carry the whip up to and push it through between the cutters, and one or more behind or on the other side of the cutters to pull the whip through, I am enabled to round the whip the whole length, and not leave the ends to be finished by hand. This device for rotating and carrying an article in the direction of its length, may be applied to other machines for other purposes than the one for which I principally design using it.

Having thus fully described my invention, what I claim as new, and desire to secure by Letters Patent, is—

1. The combination of a rotating hollow mandrel and two toothed wheels rotating with the mandrel, and also around their axis, for the purposes herein set forth.

2. The combination of the scroll-cam A, hollow mandrel C, sheath D, and toothed wheels G G, substantially as and for the purposes herein set forth.

3. The toggle-levers I and spiral springs J, in combination with the toothed wheels G G, sheath D, hollow mandrel C, and scroll-cam A, substantially as and for the purposes herein set forth.

In testimony that I claim the foregoing as my own I affix my signature in presence of two witnesses.

HEZEKIAH LOMBARD.

Witnesses:

R. B. ROBINSON,  
H. H. SAUNDERS.