

F. A. MEREDITH.
 Bobbin-Winder for Sewing-Machines.

No. 208,410.

Patented Sept. 24, 1878.

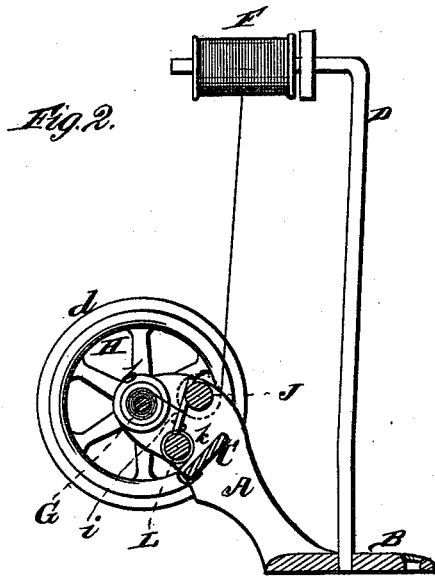
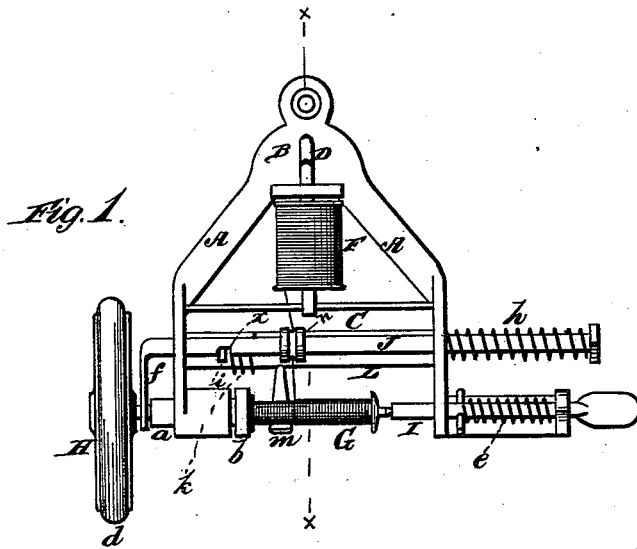

WITNESSES
Robert Everett,
Jos. J. Sheehy.

INVENTOR.
Fenton A. Meredith.
 By *J. S. Smith & Co.*
 ATTORNEYS.

UNITED STATES PATENT OFFICE

FENTON A. MEREDITH, OF HAGERSTOWN, MARYLAND.

IMPROVEMENT IN BOBBIN-WINDERS FOR SEWING-MACHINES.

Specification forming part of Letters Patent No. 208,410, dated September 24, 1878; application filed July 20, 1878.

To all whom it may concern:

Be it known that I, FENTON A. MEREDITH, of Hagerstown, in the county of Washington and State of Maryland, have invented a new and valuable Improvement in Bobbin-Winders; and I do hereby declare that the following is a full, clear, and exact description of the construction and operation of the same, reference being had to the annexed drawings, making a part of this specification, and to the letters and figures of reference marked thereon.

Figure 1 of the drawings is a representation of a plan of my bobbin-winder. Fig. 2 is a side elevation, partly in section, of the same on line *x x*, Fig. 1.

My invention relates to bobbin-winders for sewing-machines; and it consists in the improvements in the construction of the same hereinafter fully described, and particularly pointed out in the claim.

The annexed drawings, to which reference is made, fully illustrate my invention.

The foot or frame of my bobbin-winder is cast in a single piece, with two diverging arms, A A, united at their lower ends to form the foot B, and near their upper ends they are connected by a cross-bar, C. The foot B is to be attached in the usual manner on the bed of the machine, so as to throw the winding-wheel in and out of gear with the fly-wheel of the machine. To the foot B is attached a rod, D, upon the end of which the spool F is placed.

G represents the bobbin, one end of which is placed in a hollow cup, *b*, on the inner end of a shaft, *a*. This shaft has its bearing in the end of one of the arms A, and on its outer end is secured the wheel H, which has the usual rubber ring or band *d* placed around it, so that it will be rotated by frictional contact with the fly-wheel of the machine. The other end of the bobbin is placed in the end of a shaft or bar, I, which has its bearings in the other arm, A, said arm being constructed to form two bearings for the same. This shaft or bar cannot rotate, but is capable of end-wise movement in its bearings, and has a spring, *e*, around it to throw it inward, as shown.

Through the two arms A A passes a shaft, J, one end of which is formed or provided

with an arm, *f*, and the outer end of this arm fits in a groove or between collars on the outer end of the shaft *b*. The opposite end of the shaft J is provided with a spring, *h*, so arranged that its tendency will be to draw the arm *f* against the outside of the main frame. This, of course, also draws the wheel H close to said frame.

On the shaft J is a notch, *x*, as shown, into which drops a pin, *i*, projecting from a shaft, L, having also its bearings in the arms A A. The shaft L has a spring, *k*, coiled around it, and arranged in such a manner as to cause the pin *i* to drop into the notch *x* as soon as the shaft J is moved, so that said parts coincide. From the shaft L projects a flat arm, *m*, at the side of the bobbin.

The thread from the spool F is wound around a roller, *n*, on the shaft J, so as to produce sufficient tension, and is then carried to the bobbin. By now pressing the end of the shaft J the wheel H will be thrown in frictional contact with the wheel of the machine, and is held there by the pin *i* from the shaft L falling into the notch *x* on the shaft J. The arm *m* then stands at such a distance from the bobbin that a suitable quantity of thread can be wound thereon; but as soon as the bobbin is full this arm is pushed outward by the wound thread on the bobbin. This at once raises the pin *i* out of the notch *x*, and the spring *h* throws the winder out of gear.

By this invention the bobbin can be wound without interfering with the sewing, as the winder is thrown out of gear the instant the bobbin is full.

What I claim as new, and desire to secure by Letters Patent, is—

In a bobbin-winder, the combination, with the shaft J, provided with arm *f* and notch *x* and spring *h*, of the shaft L, provided with pin *i* and arm *m*, the spring *k*, wheel H, and shaft *a*, as and for the purpose set forth.

In testimony that I claim the above I have hereunto subscribed my name in the presence of two witnesses.

FENTON A. MEREDITH.

Witnesses:

JAS. J. SHEEHY,
ROBERT EVERETT.