

J. W. POST.
 Gear-Cutting Attachment for Lathes.

No. 208,491.

Patented Oct. 1, 1878.

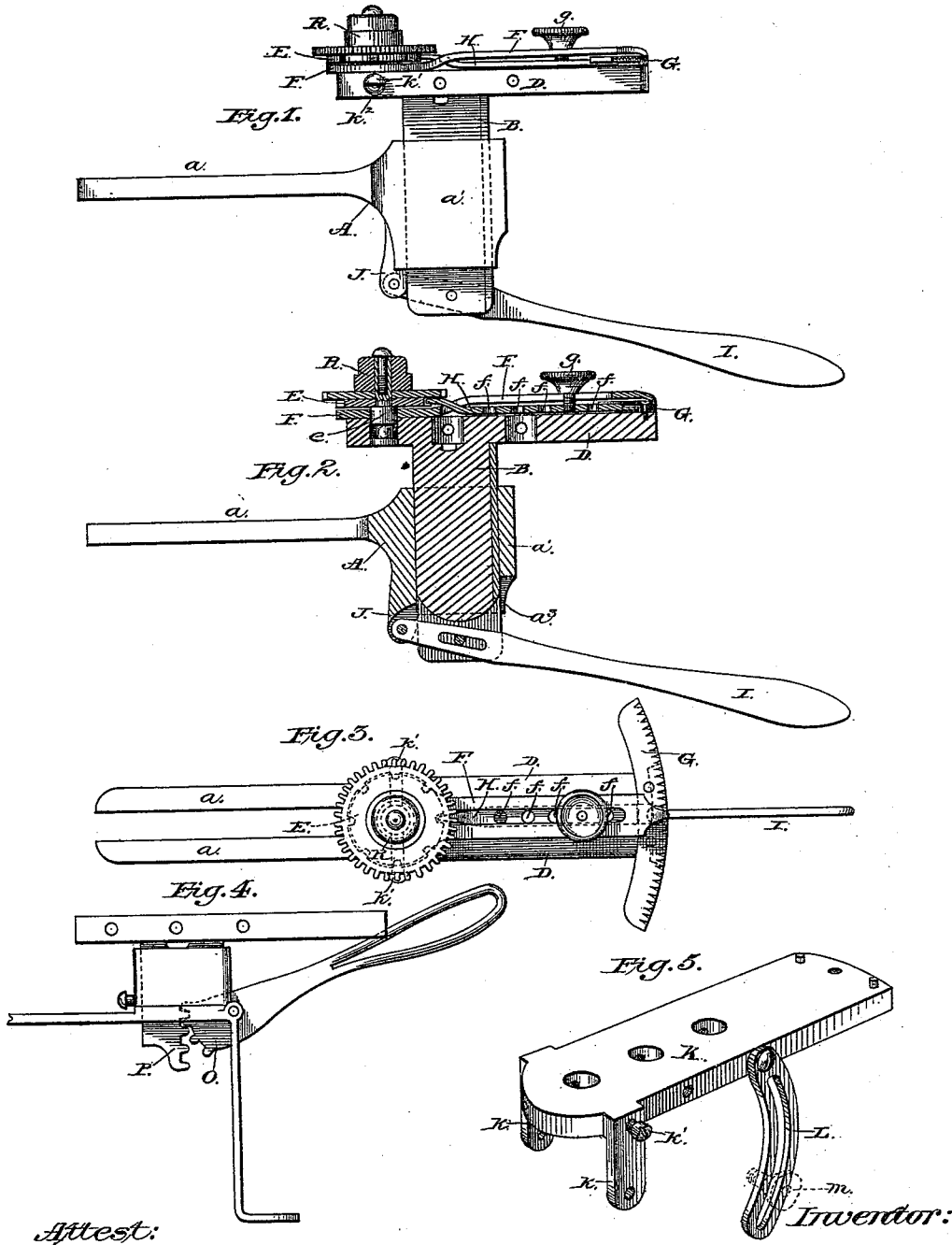

Attest:
 J. H. Nottingham
 D. P. Lovell

Inventor:
 John W. Post

UNITED STATES PATENT OFFICE.

JOHN W. POST, OF NEW YORK, N. Y., ASSIGNOR TO USEFUL MACHINERY COMPANY.

IMPROVEMENT IN GEAR-CUTTING ATTACHMENTS FOR LATHES.

Specification forming part of Letters Patent No. 208,491, dated October 1, 1878; application filed March 11, 1878.

To all whom it may concern:

Be it known that I, JOHN W. POST, of New York, in the county of New York and State of New York, have invented certain new and useful Improvements in Gear-Cutting Attachments for Lathes; and I do hereby declare that the following is a full, clear, and exact description thereof, which will enable others skilled in the art to which it appertains to make and use the same, reference being had to the accompanying drawings, and to letters of reference marked thereon, which form a part of this specification.

This invention relates to an improved gear-cutting attachment for lathes; and it has for its object to provide a device which may be attached to the slide-rest of an ordinary lathe, and by means of which all the varieties of work usually effected by special machinery may be accomplished at a cost infinitely less than where such special machines have heretofore been required.

To this end my invention consists in a peculiarly-constructed wheel or rack-holder, which may be directly attached to the slide-rest of an ordinary lathe, and which may be adjusted thereon so as to present the work in such position as to be either cut into plain, beveled, or scroll gear-wheels and racks, as may be desired.

In the drawings, Figure 1 represents a side elevation of my improved device; Fig. 2, a vertical sectional view thereof; Fig. 3, a top view. Fig. 4 represents a vertical section of a modification of my invention, and Fig. 5 a view of the supplementary table.

The letter A represents a horizontal rest, having a slotted or bifurcated shank, *a*, by means of which it may be secured to the slide-rest of a lathe by an ordinary binding screw or nut. Said rest is provided with a head, *a*¹, having a vertical slot, *a*², formed therein, in which is fitted the vertical shank B of a horizontal table, D. Said horizontal table serves to support and hold the devices for supporting the work to be cut and adjusting the same with respect to the revolving cutter, which is secured to the mandrel of the lathe.

The letter E represents a disk, firmly secured to a journal, *e*, the lower end of which

is provided with an annular groove, into which holding-screws extend, through the table, to keep the plate in position, and also has a bearing in the front end of the table D. Said disk is provided with a series of equidistant slots at its periphery, for the purpose to be hereinafter explained.

Immediately below said disk, and through which the lower portion of the journal thereof revolves, is located a slotted indicator, F, which extends toward the rear of the table D, and is provided with a pointed extremity adapted to swing in the arc of a circle over a graduated sector, G. Directly below said slotted indicator is located a sliding pawl, H, which serves the double purpose of engaging the slots in the disk E and forming a binding in connection with said indicator to secure it in position, the pawl being provided with a series of screw-apertures, *f*, into which a binding-screw, *g*, may be secured, so as to bind the two together and hold the indicator in position.

The sliding shank of the table D is provided at its lower end with a lever, I, fulcrumed to a bracket, J, attached to or forming part of the said head, so that it may be elevated or depressed to properly present the work to the tool.

In order to provide for work of different diameters, the table D is formed with a series of bearings for the reception of the journal of the disk E, and the pawl H is provided with a series of screw-threaded apertures, by means of which it may be regulated to correspond with the changed position of the indicator.

The letter K represents a supplementary table, which is provided with downwardly-depending side lugs, *k k*, which are adapted to embrace the sides of the primary table D and be secured thereto by means of set-screws *k*¹ at various points, as shown at *k*², to adapt the device to work of different diameters, as more fully hereinafter explained. Said supplementary table is provided near its front end with a sector, L, adapted to work in a guide on the table D, or by a set-screw, *m*, by means of which the said supplementary table may be set at any desired angle with respect to the horizontal table. Said supplementary table

in its general arrangements is a counterpart of the horizontal table, and is adapted to support and carry the work, and is provided with an indicator and graduated sector, similar to the indicator and sector of the stationary table. The object of said supplementary table is to provide for presenting the work at an angle to the tool, so as to cut beveled gearing of any pitch, as will be readily perceived.

In the modification shown in Fig. 4 the elevating-lever is shown pivoted in the head of the rest, and provided at one end with a ratcheted segment, O, which is adapted to engage a rack, P, formed on the shank of the horizontal table, whereby said table may be elevated.

The wheel to be cut is clamped upon the journal of the disk (special collars may be fitted on the journal for correctly centering work of different diameters) by means of a binding-nut, R, so as to be held firmly thereto and travel with it when rotated.

The operation of my invention will be readily understood in connection with the above description. The rest A, being secured upon the ordinary slide-rest of a lathe, presents the horizontal table D and its work to the rotating cutter secured to the revolving mandrel of the lathe. The indicator and graduated sector serve to regulate the pitch of the gear-wheel to be cut, and the slotted disk, upon which the work is supported, serves to allow the work to be rotated, so as to allow all portions of its periphery to be cut to be properly presented to the tool, the sliding pawl serving to secure said slotted disk in proper position.

Having thus described my invention, what I claim, and desire to secure by Letters Patent, is—

1. In combination with the horizontal table, the rotating slotted disk for supporting the work, and the indicator and sliding pawl, for adjusting the position of said disk and the work in respect to the cutting-tool, substantially as specified.

2. The combination of the slotted indicator, sliding pawl, and the set-screw for binding the two together, with the graduated sector and work-holding disk, substantially as and for the purposes specified.

3. In combination with the horizontal table provided with a series of bearings, as described, the slotted indicator and pawl, provided with a series of screw-threaded apertures for the reception of a movable binding-screw, substantially as and for the purposes set forth.

4. In combination with the horizontal table, the supplementary table, adapted to be secured thereto at various angles, and provided with work-carrying devices, for the purpose of cutting beveled and scroll gear, substantially as herein set forth.

In testimony that I claim the foregoing as my own I affix my signature in presence of two witnesses.

JOHN W. POST.

Witnesses:

J. R. NOTTINGHAM,
WILLIAM FITCH.