

C. G. BARND. •  
Feather-Renovator.

No. 208,558

Patented Oct. 1, 1878.

Fig. 1.

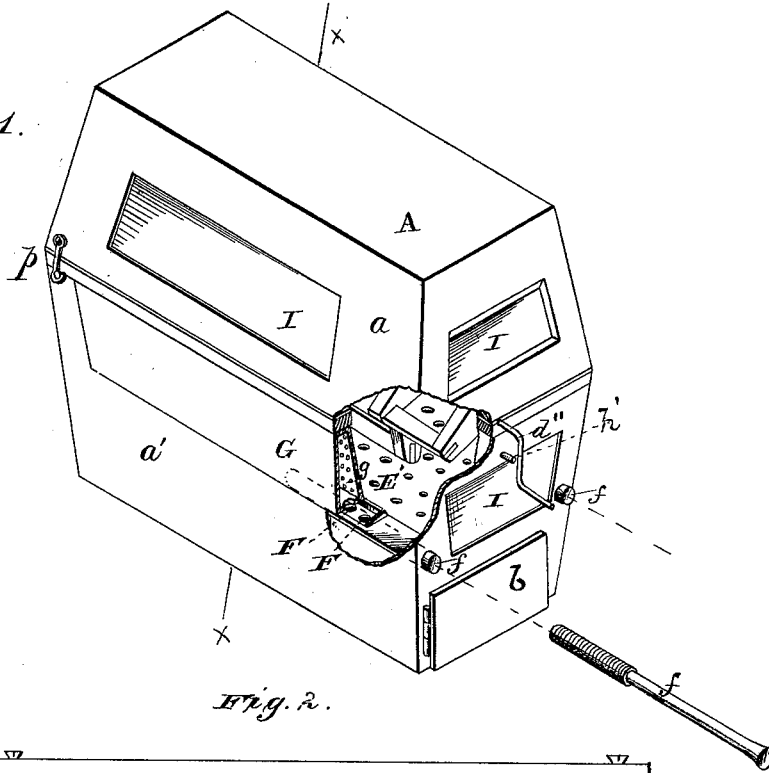

Fig. 2.

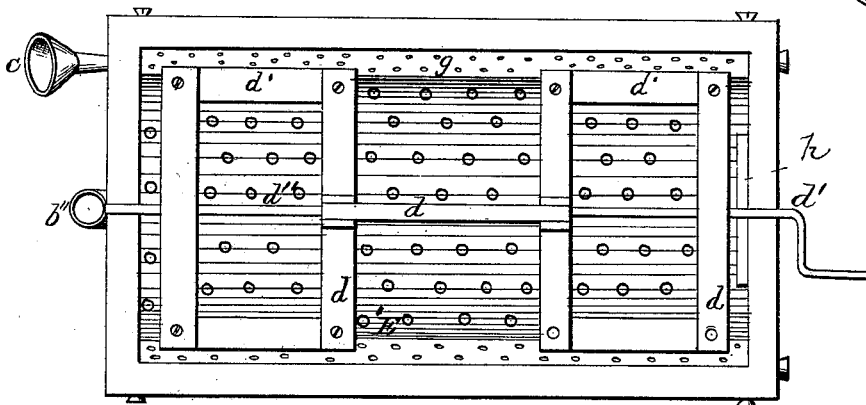
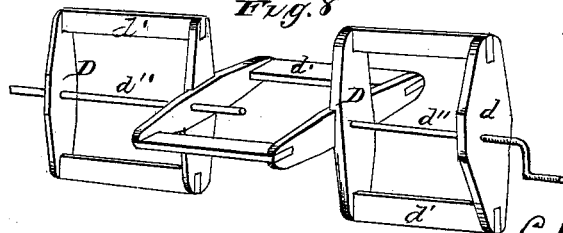

Fig. 3.



WITNESSES  
F. L. Curand  
P. M. Kieble.

By his Attorney

INVENTOR  
Chas. G. Barnd  
L. Deane.

C. G. BARND.  
Feather-Renovator.

No. 208,558.

Patented Oct. 1, 1878.

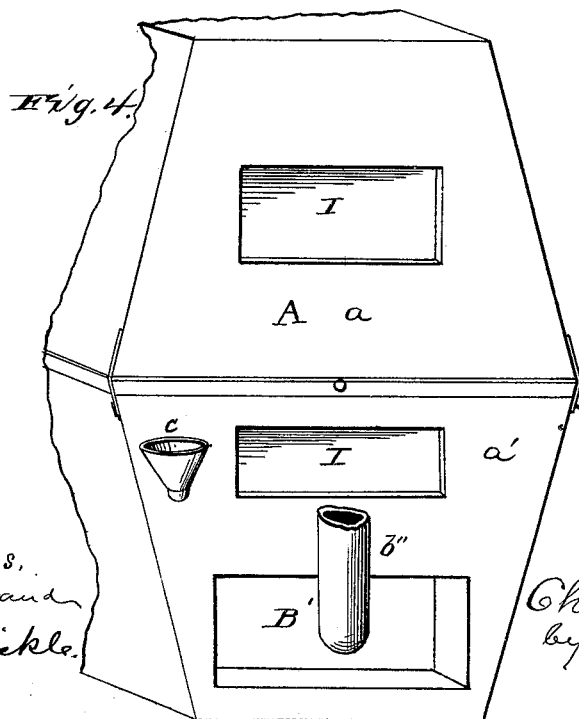
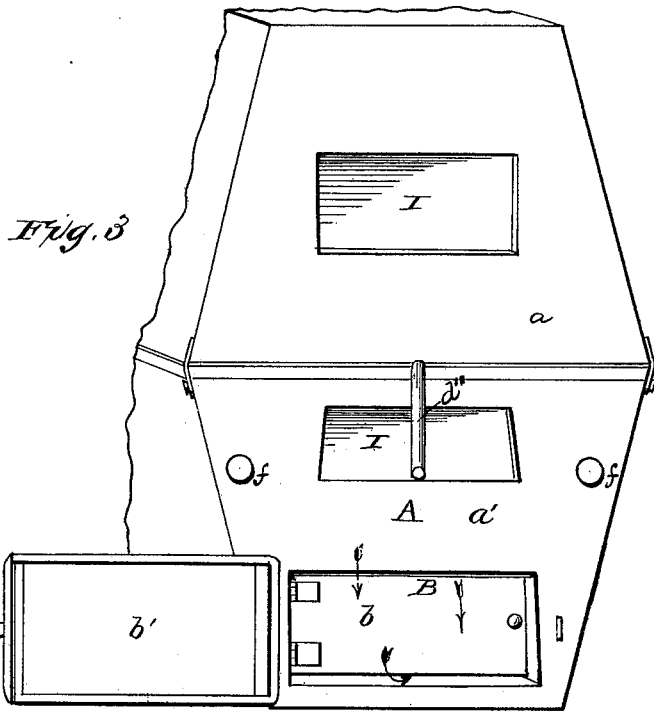

Witnesses,  
A. L. Curran  
P. W. Nickle.

Inventor,  
Charles G. Barnd  
by L. Deane  
Attorney.

C. G. BARND.  
Feather-Renovator.

No. 208,558.

Patented Oct. 1, 1878.

Fig. 5.

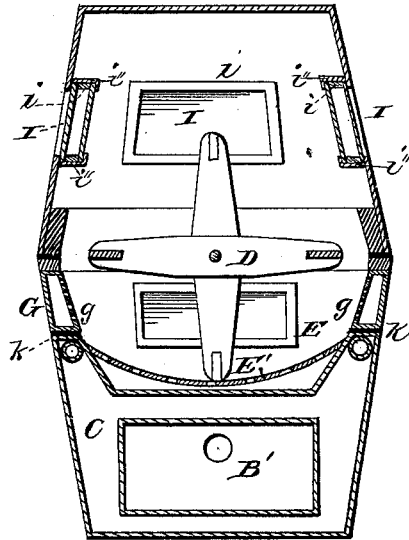

Fig. 6.

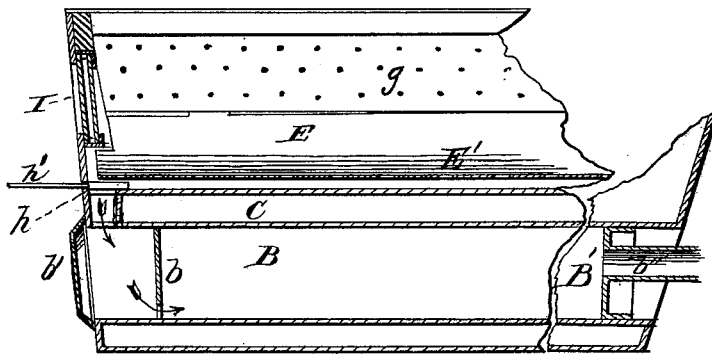
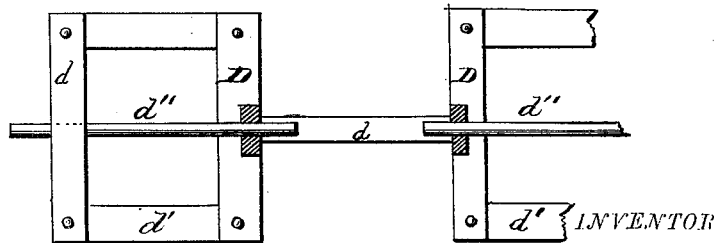

Fig. 7.



WITNESSES  
F. L. Curaud,  
P. M. Hinkle.

By his Attorney

INVENTOR  
Charles G. Barnd  
L. Deane

# UNITED STATES PATENT OFFICE.

CHARLES G. BARND, OF FINDLAY, OHIO.

## IMPROVEMENT IN FEATHER-RENOVATORS.

Specification forming part of Letters Patent No. **208,558**, dated October 1, 1878; application filed August 17, 1878.

*To all whom it may concern:*

Be it known that I, CHARLES G. BARND, of Findlay, in the county of Hancock and State of Ohio, have invented certain new and useful Improvements in Renovators for Feathers, &c., of which the following is a specification:

Figure 1 is a perspective view of the device, with portions of the external walls broken away to disclose the internal construction. Fig. 2 is a top-plan view, with the cover or upper section removed. Fig. 3 is the front, in perspective. Fig. 4 is the rear, in perspective. Fig. 5 is a vertical cross-section on line *x x* of Fig. 1. Fig. 6 is a central longitudinal section. Figs. 7 and 8 are views of the agitator.

The present invention relates to improvements in that class of devices used for renovating and cleaning feathers, wool, hair, and the like articles, substances, or materials; and consists more particularly in the construction and combination of the several parts of the device, whereby in an individual, portable, and compact form are embodied the steam and heat producing apparatus, together with the means or mechanism for renovating; also, in the separable and detachable agitator; also, in combining double windows with a renovator constructed and adapted to operate substantially as hereinafter described; also, in the means provided for introducing steam into the renovating-chamber; also, in the combination of the fire-box, having two doors in front, with the boiler; also, in the renovating-chamber, having a concave bottom formed by the boiler-top, and provided with a removable floor-plate, combined with an exit-passage way to the furnace; also, in the fire-box, having its rear head inside the boiler-walls, all as will be hereinafter more particularly set out in the claims.

In the accompanying drawings, A denotes the feather-renovator, with an upper part or section, *a*, placed upon the base-section *a'*. These two parts may be of nearly equal size, and each may have, in general, the shape of a truncated pyramid, so that when the base and larger part of the upper is placed upon the top and larger part of the lower the whole device is polygonal in shape. The upper part,

*a*, is removable from the base-part *a'*; or it may be secured thereto by means of hasp *p*, or in any convenient way to admit of ready securing or easy removal.

In the bottom of the part *a'* is the fire-box, B, which is surrounded on the top, sides, and bottom by the boiler-space C. The main door *b* of the fire-box is placed a little within the outside wall of the boiler or front of the renovator, while, at a short distance in front of this door *b*, and on the outside of the renovator, is the outer door, *b'*. The top or upper part of the boiler is made dishing or concave, to conform to the path of the agitator D in its revolutions. In this concavity is fitted the grating or perforated plate *E'*, through which the dirt and any foreign matter escaping from the article treated falls. The flue or passage-way *h*, in the front part of the device, between the outer casing and the boiler, gives exit-passage for such refuse to the space between the two furnace-doors. The inner furnace-door, *b*, has apertures, dampered or otherwise, through which said débris will flow into the fire, when it will be consumed, and also may allow vent or escape for useless steam during the steaming and drying processes. A damper, *h'*, moving on the floor of the renovator, will control said passage *h*.

Steam from the boiler finds its way into the renovating-chamber E by the following course—namely, first, through side apertures, F, near the top of the boiler-walls, and then into side chambers, G, which extend lengthwise of the walls from front to rear in the upper part of base-section *a'*, and have perforated inner faces, *g*, affording free escape for steam into all parts of the chamber E. The apertures F can be controlled by cylindrical or piston valves *f*, or in any convenient way. The chambers G may be hinged in the walls of the device, or made so as to be easily put in and taken out, or in any convenient way adapted and applied.

The agitator D is made in sections, as many as may be desired, each made strongly of a rectangular frame, composed of end pieces *d* and longitudinal pins *d'*, forming beaters, and the adjoining sections are matched and fitted each to the other at right angles, and these

placed on shaft *d''*, which is mounted longitudinally in or on the top of the walls, or in any proper way.

The object of this peculiar construction is to provide a sectional agitator, that can be readily taken apart and packed when occasion requires. This construction of the agitator also gives a very irregular outline to it, and will cause it, in action, to thoroughly operate on all portions of the article placed in the renovating-chamber. Motion can be communicated to the agitator by hand or power.

The boiler C can be filled by funnel *c*, or in any suitably and proper way. The pipe attached to this funnel may have a cut-off or cock, and these parts may be constructed so as to operate as a safety-valve. The rear head, B', of the fire-box B is placed at some distance within the walls of the boiler, for the purpose of preventing any dangerous or disagreeable radiation of heat at this point.

By the construction now shown the radiated heat will be spent, in a large degree, on the adjacent walls of the boiler, and such portions as are emitted outside the device cannot do any injury. The exit-pipe *b''* of the fire-box, being placed on the rear head, B', is also so placed and fixed that it cannot harm by being too much heated. Suitable dampers can be placed in the front of the fire-box, or in the two doors *b* and *b'*; also in the exit-pipe *b''*.

In the walls of top section *a* are windows I, of any desired number and size. These are made of glass or mica, or like translucent material. As now shown, each window is formed by two plates of glass, set a little apart from each other in frame *i*, which frame is permanently or detachably secured in the aperture cut for it in the wall, and sustained therein by brackets or supports *i''*. In like manner, in the walls of base *a'* any suitable number of like windows may be placed. By this construction the glass will resist all the influences of the steam or heat, and will allow at all times the interior of the renovator to be inspected.

Packing *k* can be put between the upper and lower sections, *a* and *a'*, if desired, and on the doors.

The operation of the machine is as follows: The upper section, *a*, is taken off and reversed and placed on the floor. Feathers, wool, hair, or the article to be renovated is introduced into it and carefully examined, and this section *a* is then lifted or carried to the lower section, and the feathers or article to be renovated turned into the machine. By drawing the valves *f* steam can be admitted into the chambers G G, and thence into the renovating-chamber; or steam may be admitted directly into the renovator without the use of the inlet-chambers, as may be desired. The agitator is kept constantly in motion and steam kept on until the washing process is finished. The valves *f* are then closed, the valve *h'* and the inlet-chambers G G slightly opened by turning them on their hinges, or in any suitable way,

and the outlet fire-box door *b'* closed. This causes a current of air to pass through the feathers or like articles, which are constantly exposed to the action of the heated surface of the boiler-top by motion of the agitator, and the gas and steam pass through the flue or passage-way *h* into the furnace, where it is consumed. The feathers or articles treated are ejected from the machine by raising one side of top section *a* or removing one of its inlet-chambers G G and turning the agitator.

The construction of the two parts of the case is such that the lower part will nest into the upper, when inverted for that purpose, and thus they can be packed into a close compass. The agitator, also, being taken apart, will pack into the open top or renovating-chamber. These features are of special importance and value in transporting or storing the device and its appurtenances.

I have thus provided a cheap and strong machine of simple construction, durable, and portable. It can be easily handled, and its operations can be readily inspected. In use it can, without any difficulty, be moved from place to place or house to house when it is to be used.

I am aware that heretofore the bottoms of renovating-chambers of like devices have been made concave and heated by steam, and I lay no claim on this feature by itself.

Having thus described my invention, what I claim as new, and desire to secure by Letters Patent, is—

1. The renovator A, composed of sections *a a'*, having fire-box B, with doors *b* and *b'*, rear head, B', boiler C, valves *f*, movable steam-chambers G, and agitator D, the whole constructed and combined in an individual and portable device, substantially as and for the purposes set forth.

2. The separable and detachable agitator D, composed of rectangular sections or frames, each section formed of end pieces *d* and beaters *d'*, and the several sections halved together at right angles, substantially as and for the purposes set forth.

3. The renovator A, made in two parts, *a* and *a'*, having double windows I, and provided with agitator D, steam-chambers G, as described, fire-box B, and boiler C, substantially as and for the purposes set forth.

4. In the renovator A, the hinged or removable steam-chambers G, having perforated face *g*, combined with boiler C and valved apertures F, substantially as and for the purposes set forth.

5. In the section *a'*, the combination of fire-box B, having head B' and doors *b b'*, with boilers C, having a top dishing or concave in its general outline, substantially as and for the purposes set forth.

6. In a renovator, substantially as described, the combination of perforated bottom E' of chamber E with the concave top of the boiler B, and with flue or passage-way *h*, and damper

*b'*, substantially as and for the purposes set forth.

7. In a renovator, A, substantially as described, the rear fire-box head, B', carrying exit-flue *b''*, combined with boiler C, substantially as and for the purposes set forth.

8. The windows I, each composed of double lights set in frame *i*, and combined with brackets *i''* in the wall of the renovator, substantially as and for the purposes set forth.

In testimony that I claim the foregoing as my own I affix my signature in presence of two witnesses.

CHARLES GUSTAVUS BARND.

Witnesses:

JACOB F. BURKET,  
PETER PIFER.