

J. W. HUMPHREYS.
Ditching-Machine.

No. 208,682.

Patented Oct. 8, 1878.

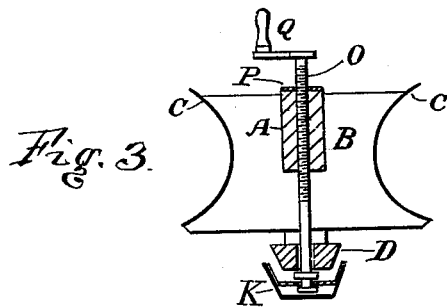
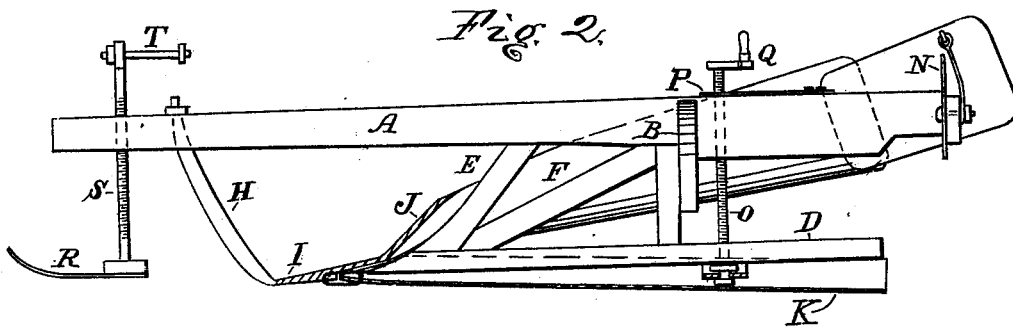
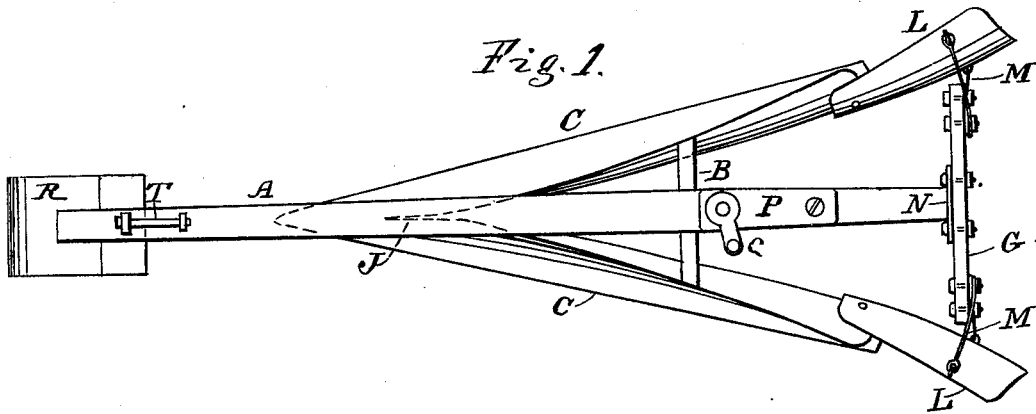

Inventor:

James W. Humphreys,

By Theodore Mungen,

Attorney.

Witnesses:
W. Burris
H. A. Daniels

UNITED STATES PATENT OFFICE.

JAMES W. HUMPHREYS, OF OTTERBEIN, INDIANA.

IMPROVEMENT IN DITCHING-MACHINES.

Specification forming part of Letters Patent No. **208,682**, dated October 8, 1878; application filed June 11, 1878.

To all whom it may concern:

Be it known that I, JAMES WILLIAM HUMPHREYS, of Otterbein, in the county of Benton and State of Indiana, have invented certain new and useful Improvements in Ditching-Machines; and I do hereby declare that the following is a full, clear, and exact description of the same, reference being had to the accompanying drawing, making a part of this specification, in which—

Figure 1 represents a plan of my invention. Fig. 2 represents a side elevation of the same, partially in section. Fig. 3 represents a transverse vertical section.

This invention has relation to that class of ditching-machines commonly called "surface-ditchers," and designed to cut in old ditches, as well as to run a second time in new ones, for the purposes of cutting and removing the earth and depositing it at the sides of the ditch; and it consists of a knife and two concave mold-boards, provided with shear or cutting edges and adjustable wings, and a hinged adjustable sole, for elevating and depressing the rear end of the machine, all of which will be hereinafter more fully described, and particularly pointed out in the claims.

In the accompanying drawing similar letters of reference indicate like parts of the invention.

The frame of the machine is composed of the beam A, the fixed cross-piece B, provided with concave ends, to form the central point of attachment for the concave mold-boards C, the shoe D, braces E F, and the adjustable cross-piece G at the rear end of the beam A. The knife or cutter H inclines forward and upward from the plow-point I to the beam A, and serves as a support for the forward end of said beam. The two concave mold-boards C are united at the point I, their forward edges, above the point I, forming a cutter, J, and their lower straight cutting or shear edges extending backward and upward from the point I—backward at angles of about thirty degrees to the beam A, and upward at angles of about fifteen degrees to the adjustable sole K when in line with the shoe D. The adjustable wings L are removably pivoted to the rear ends of the concave mold-boards C, and are connected, by adjusting-rods M, to the adjustable cross-

piece G, which is rendered vertically adjustable by screw-bolts in the slotted plate N, secured to the rear ends of the beam A. The adjustable sole K is hinged at its forward end to the under side of the point I, incases the bottom and sides of the shoe D, and is connected with an adjusting-screw, O, passing vertically through the beam A and the shoe, and working in a threaded hole in a plate, P, secured to the face of the beam A. A crank or lever, Q, is used to operate the screw O. A vertically-adjustable shoe, R, is secured by a threaded shaft, S, near the front end of the beam A, and a lever, T, is used to operate it. The mold-boards C have their lower or cutting edges straight, and receding backward from the point I at angles of about thirty degrees to the beam A. The faces of the mold-boards C are curved inward and upward, to form the cutter J at their forward ends, and to bend over so that their upper edges will come in the same vertical plane with the lower edges at the rear of the mold-boards. This forms in the faces of each of the mold-boards a screw-curve, which causes the loosened earth to be carried backward and upward, to be deposited upon the surface at the sides of the ditch. The straight or cutting edges of the mold-boards C cut the earth throughout their entire length, and it is carried, by pressure, backward and upward.

It frequently occurs that the surface of the ground through which the ditch is to be dug or cleaned out is uneven; and without some means of elevating and depressing the rear end of the machine the banks at some points would be too high to permit the loosened earth to be deposited upon the surface at the sides of the ditch. By the employment of the hinged adjustable sole K, operated by the vertical screw O, this defect can be overcome at will by elevating or depressing the rear end of the machine to suit the unevenness of the surface. The ditch needs sometimes to be dug so deep that the mold-boards C will not extend sufficiently high to deposit the loosened earth upon the surface, even when the rear end of the machine has been elevated by the screw O to its fullest extent. To overcome this defect the adjustable wings L should be attached to the rear ends of the mold-boards C, and

connected directly to the slotted plate N by the adjusting-rods M. To meet the unevenness in the surface, the rear end of the machine should be elevated and depressed in the same manner as before the adjustable wings L were attached.

The depth to which the machine is to cut is regulated by the vertically-adjustable shoe R, at the front of the beam A.

Having thus described my invention, what I claim as new and useful, and desire to secure by Letters Patent of the United States, is—

In a surface-ditching machine, the hinged adjustable sole K, in combination with the adjusting-screw O and the adjustable shoe R, constructed and operating substantially as and for the purposes set forth.

In testimony that I claim the foregoing improvements as above described I have hereunto set my hand and seal this 29th day of May, 1878.

JAMES W. HUMPHREYS. [L. S.]

Witnesses:

JOHN A. SAVAGE,
GEO. H. BRILLEY.