

G. H. ZSCHECH.
Feed-Water Heater, &c.

No. 208,701.

Patented Oct. 8, 1878.

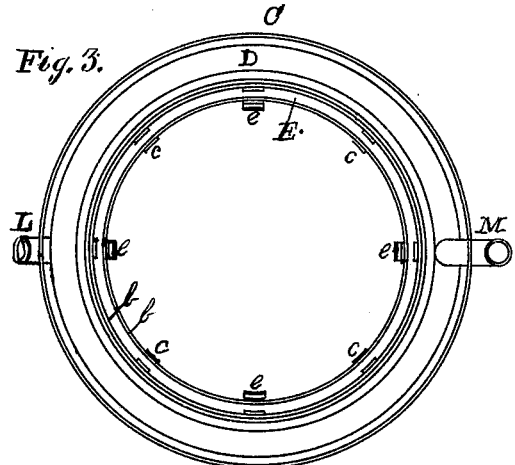
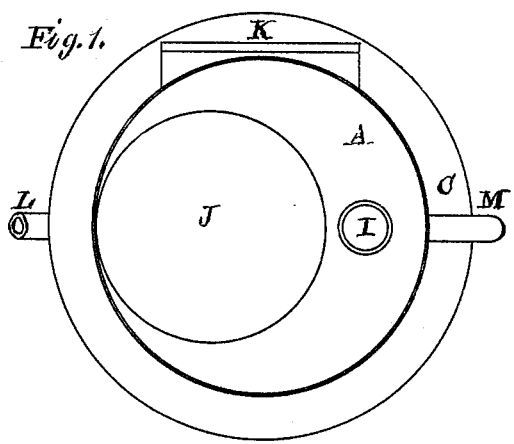
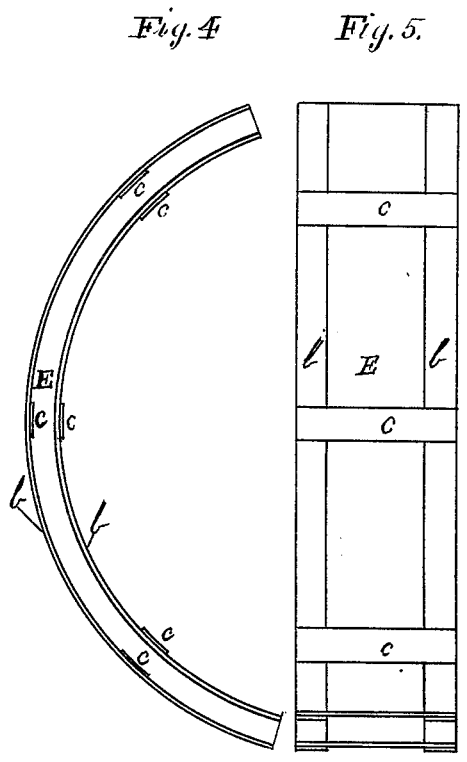
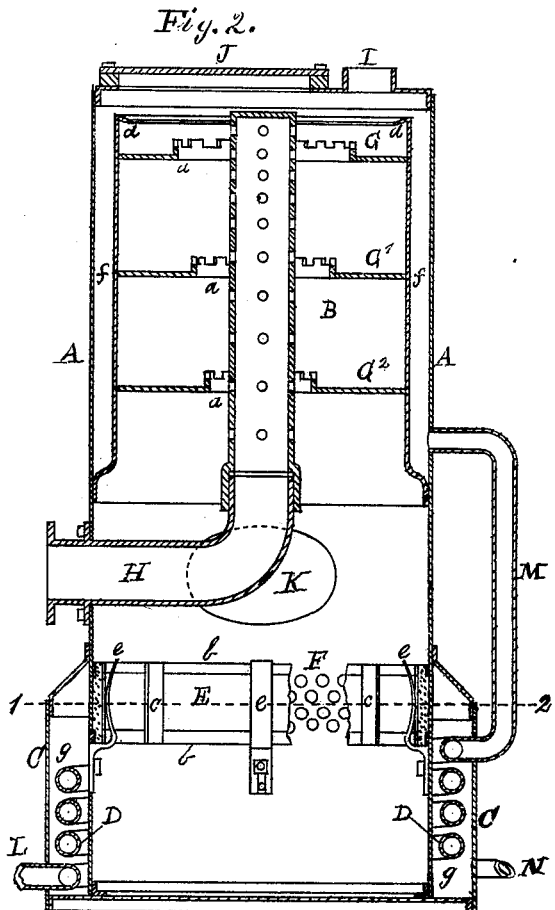

Witnesses:
J. S. Lightford
Jno. S. Johnson.

Inventor:
Gustavus H. Zschech.

UNITED STATES PATENT OFFICE.

GUSTAVUS H. ZSCHECH, OF INDIANAPOLIS, INDIANA.

IMPROVEMENT IN FEED-WATER HEATERS, &c.

Specification forming part of Letters Patent No. 208,701, dated October 8, 1878; application filed July 29, 1878.

To all whom it may concern:

Be it known that I, GUSTAVUS H. ZSCHECH, of Indianapolis, in the county of Marion and State of Indiana, have invented a new and useful Improvement in Feed-Water Heaters and Sediment-Extractors for Steam-Boilers, of which the following is a specification:

This invention has relation to means of heating the feed-water for steam-boilers by the exhaust-steam of the engine to such a degree of temperature as to cause the separation of the impurities from the water and the depositing of the same upon suitable surfaces before it enters the boiler.

My object is to utilize the exhaust-steam of the engine for heating the feed-water, and to conduct this steam into the center of a cylinder by means of a vertical thickly-perforated pipe, the feed-water passing from an annular chamber inside of said cylinder, and falling in showers from salt-arresting pans surrounding the said perforated pipe, as will be hereinafter more fully explained.

Another object is to conduct the feed-water through a pipe-coil located near the bottom of the apparatus, as will be hereinafter explained.

I will now proceed to describe my invention by the assistance of the annexed drawing.

Figure 1 of the drawings is a representation of the plan or top view of my apparatus. Fig. 2 is a vertical section through the center of the same; Fig. 3, a horizontal transverse section at the line 1 2. Fig. 4 is a top view of a segment of the filtering-belt on an enlarged scale; Fig. 5, a side view of the same, also on an enlarged scale.

The same letters of reference apply to the same parts on each of the figures.

A A designate the cylindrical case of the heater, inside of which is another case, B, forming an annular space, *f f*, extending to about half the length of the principal case A downward. From the bottom extends an external case, C, forming the annular space *g*. In this space is placed a pipe-coil, D D, communicating with the supply-pump or water-tank by means of the branch L. The cold water flows through the coil D and branch M to the annular space *f f*, and overflows the case B at the flange *d d*; thence it falls on the

pan G, from which it passes through the notched flanges *a* to the pan G¹, and in the same manner from the pan G¹ to the pan G².

The diameters of the circular openings in the pans are made gradually smaller, according to their distance from the top, so that the water as it flows from the one will fall into the next one immediately below it.

The exhaust-steam from the engine enters the pipe H and ascends, escaping through a number of perforations in the vertical portion of the pipe. It comes in contact with the descending water as it falls in a subdivided condition from the pans G G¹ G², thereby heating it to a high temperature, and causing it to deposit its salts, lime, and other impurities upon the pans. The uncondensed steam escapes by the opening I at the top of the case A.

When the water has passed over the lowest pan it falls into the lower portion of the case A, in which it ascends to the filtering-belt E. The filtering-belt E is composed of strips of felt, cloth, or other suitable material, bound together by the elastic metallic bands *b b* and vertical metallic strips *c c c*, &c., the whole being made flexible and passed into the interior of the case A through the door K, and laid on the supporting-springs *e e e e*. The part of the case A covered by the filtering-belt E is perforated, as shown at F, Fig. 2. The water passes through the filtering-belt E and perforated case A into the annular space *g g*, immersing the coil-pipe D, communicating part of its heat to the cold water in the coil-pipe, thereby heating it to a high temperature before it comes in contact with the steam in the pan-case B. The object is to heat the water gradually by means of the coil-pipe D and annular space *f f*, but not to such a temperature as to cause the separation of its impurities and their consequent deposit in the coil-pipe or annular space *f f*, so as to obstruct the free circulation of the water in these portions of the apparatus, as it is well known from experience that such is the result when the steam acts directly upon the coil-pipe, and thereby rendering the apparatus ineffective from the impossibility of cleaning out such pipes and contracted spaces.

The pans G G¹ G² are made in two pieces, and are taken out for cleaning through the opening or door J on the top of the principal case A. The heated and purified water is supplied to the feed-pump of the engine by means of the pipe N, communicating with the annular space *g*.

What I claim as new, and desire to secure by Letters Patent, is—

1. The combination of the water coil-pipe D and branch pipe M with the annular water-space *f f*, pans G G¹ G², perforated pipe H,

and case A, arranged substantially as shown and described.

2. The filtering-belt E and springs *e*, in combination with the perforated portion of the cylindrical case A and water-space *g*, arranged substantially as shown, and for the purpose set forth.

GUSTAVUS H. ZSCHECH.

Witnesses:

J. G. LIGHTFORD,
JNO. F. JULIAN.