

A. L. ATWOOD.
 Lock Work for Clock Movements.

No. 208,702.

Patented Oct. 8, 1878.

Fig 1

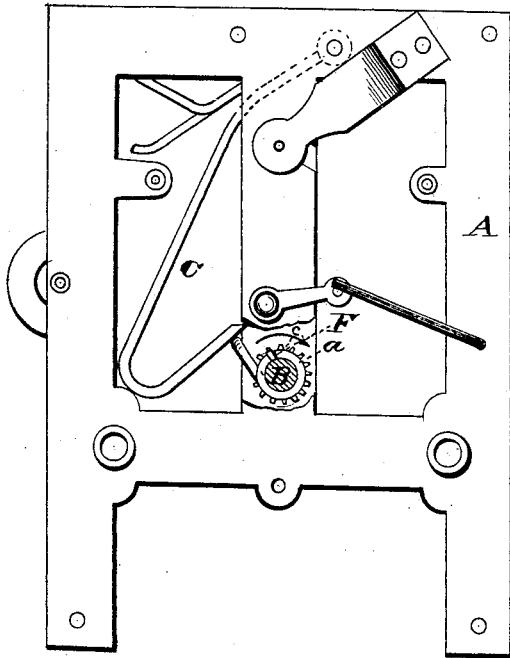

Fig 2

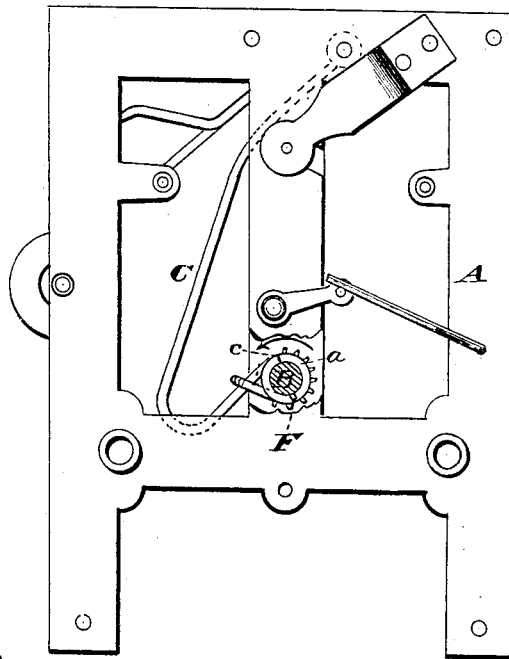

Fig 3

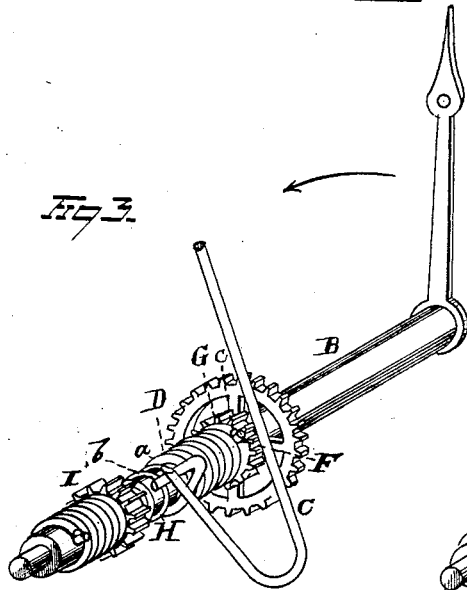
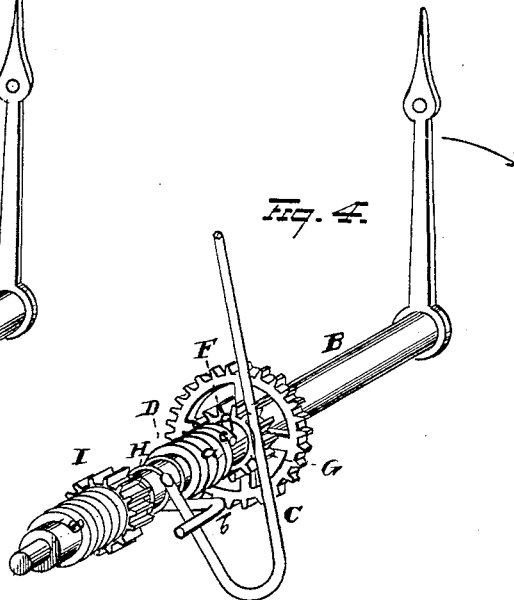

Fig. 4



WITNESSES

Edw. J. Nottingham
A. M. Bright

INVENTOR

A. L. Atwood
 By *H. A. Symmons*
 ATTORNEY

UNITED STATES PATENT OFFICE.

ANSON L. ATWOOD, OF BRISTOL, CONN., ASSIGNOR TO E. INGRAHAM & CO.,
OF SAME PLACE.

IMPROVEMENT IN LOCK-WORK FOR CLOCK-MOVEMENTS.

Specification forming part of Letters Patent No. **208,702**, dated October 8, 1878; application filed
March 16, 1878.

To all whom it may concern:

Be it known that I, ANSON L. ATWOOD, of Bristol, in the county of Hartford and State of Connecticut, have invented certain new and useful Improvements in Lock-Work for Clock-Movements; and I do hereby declare the following to be a full, clear, and exact description of the invention, such as will enable others skilled in the art to which it pertains to make and use it, reference being had to the accompanying drawings, which form part of this specification.

My invention relates to an improvement in lock-work for clock-movements, the object being to provide clocks with lock-work constructed and arranged in such a manner that the strike mechanism will not be actuated or injured when the hands of the clock are backwardly turned; and to that end my invention consists in the combination, with the center arbor and lift-wire of a clock-movement, of a yielding lift, surrounding the arbor, and provided with a cam-faced end, which engages with a stop attached to the center arbor, and is turned thereby when the hands are turned toward the right, while a reverse movement of the hands causes the stop to travel over the cam-faced end of the lift, which yields to the action of the stop and allows the latter to travel past the shoulder of the cam on the lift without rotating the latter.

In the accompanying drawings, Figure 1 is a front view of a clock-movement, with a portion thereof cut away to show the position of the mechanism when the lift-wire is raised by the ordinary operation of the clock. Fig. 2 is a similar view, showing the position of the parts when the hands are turned backward. Fig. 3 is an enlarged view of the attachment, showing the relative position of the several parts when the hands are being turned toward the right in the ordinary manner; and Fig. 4 is a similar view, showing the position of the parts when the hands are turned backward or toward the left.

As my invention only relates to a particular portion of the lock-work of a clock-movement, I will not give a detailed description of any particular clock-movement, since the improvement is adapted and intended for employment with

many of the different styles of ordinary strike-movements, as will be clearly evident to those skilled in the art to which the improvement relates.

A represents the frame, and B the center arbor, of a clock. C is the lift-wire, and forms a part of the lock-work of ordinary clock-movements.

Upon the arbor B is loosely placed a lift, D, which consists of a wire, *a*, coiled any desired number of times around the arbor, one end of the wire being formed in hook or crank form, in order that the outer end, *b*, which is parallel to the arbor, may always strike and raise the lift-wire C at the proper intervals of time when the clock is running, and actuate the strike mechanism of the clock by means of the ordinary and well-known lock-work.

F is a stop-pin, rigidly secured to the arbor in close proximity to the pinion G, against which rests the other end, *c*, of the lift D.

A light spiral spring, H, made of fine wire, is placed around the arbor B, between the pinion I and the rear end of lift D, and serves to hold the latter against the pinion G in a yielding manner.

The operation of my improved strike mechanism is as follows: When the hands are turned toward the right, as illustrated in Figs. 1 and 3, the forward end, *c*, of the lift D is pressed against the side of the pinion G by means of the spiral spring H, and thus when the center arbor is turned toward the right the stop-pin F, rigidly secured to the arbor, strikes the end *c* of the lift D and carries the latter around with the arbor, causing it to raise and actuate the lift-wire C in the ordinary manner, as clearly illustrated in Fig. 1. When the hands are turned toward the left, the outer end of the lift D engages with the hooked end of the lift-wire C, as shown in Fig. 2; and by continuing to turn the hands backward, the fixed stop on the center arbor acts against the end of the lift-coil, (which end, it will be observed, is in reality a face-cam,) and operates to force the lift against the tension of the small spiral spring H, compressing the latter, and thus allowing the stop to travel past the end *c* of the lift-coil without imparting other than a sliding movement to the lift.

Thus the lock-work acts with the same certainty as when the ordinary fixed lift is employed, while all danger of bending, breaking, or disturbing the relative position of the several parts of the lock-work is obviated by arranging the lift in the manner heretofore described, so that the hands can be turned backwardly any number of revolutions without imparting a complete revolution to the lift.

My improved lock-work attachment is simple in construction, of small initial cost, not liable to become deranged when in use, and is adapted to be readily applied to operate in conjunction with the ordinary lock-work now in use.

Instead of forming the lift from a piece of wire coiled around the arbor, it is evident that a sleeve having a cam-faced end, and a hook secured to the opposite end of the sleeve, or formed as a part thereof, would perform the same office as the construction of lift illustrated in the accompanying drawings. Again, instead of securing the stop-pin to the arbor, it may be secured to the side of the pinion against which rests the end of the sleeve or coil of the lift.

The essential feature of my invention consists in a coil or sleeve having a cam-faced end, which will be locked to the center arbor when the latter is revolved in one direction, and disengaged therefrom when the center arbor is turned in the opposite direction. Hence I do not limit myself to the exact construction and arrangement of parts shown and described; but,

Having fully described my invention, what I claim as new, and desire to secure by Letters Patent, is—

1. The combination, with the center arbor of a clock-movement, of a lift provided with a cam-faced sleeve or coil, which is pressed against a stop-pin attached to the arbor or other part moving therewith, whereby the lift is locked to the arbor when the latter is turned in one direction, and released from engagement with the stop-pin when the arbor is turned in the opposite direction, substantially as set forth.

2. The combination, with the center arbor of a clock-movement provided with a stop-piece, of a lift loosely secured upon the arbor, and a spring arranged to force one end of the coil or sleeve of the lift against said stop-pin, substantially as set forth.

3. The combination, with the center arbor of a clock-movement, of a spring-pressed lift which is adapted to be locked to the arbor by a face-cam when the arbor is turned in one direction, and released from the stop-pin when the arbor is turned in the opposite direction, substantially as set forth.

In testimony that I claim the foregoing I have hereunto set my hand this 11th day of March, 1878.

ANSON L. ATWOOD.

Witnesses:

MILES L. PECK,
THEO. B. PECK.