

E. BROWN.
Machine for Turning Needle-Blanks.

No. 208,712.

Patented Oct. 8, 1878.

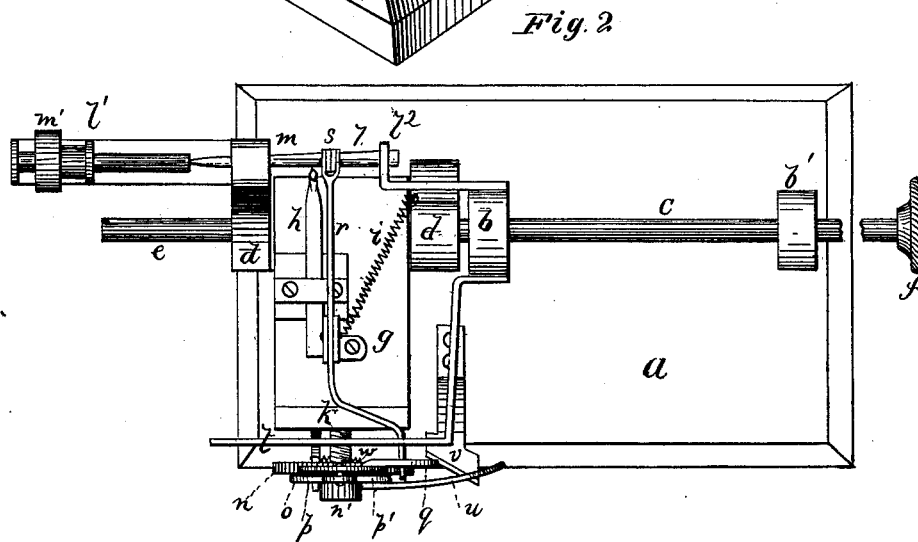
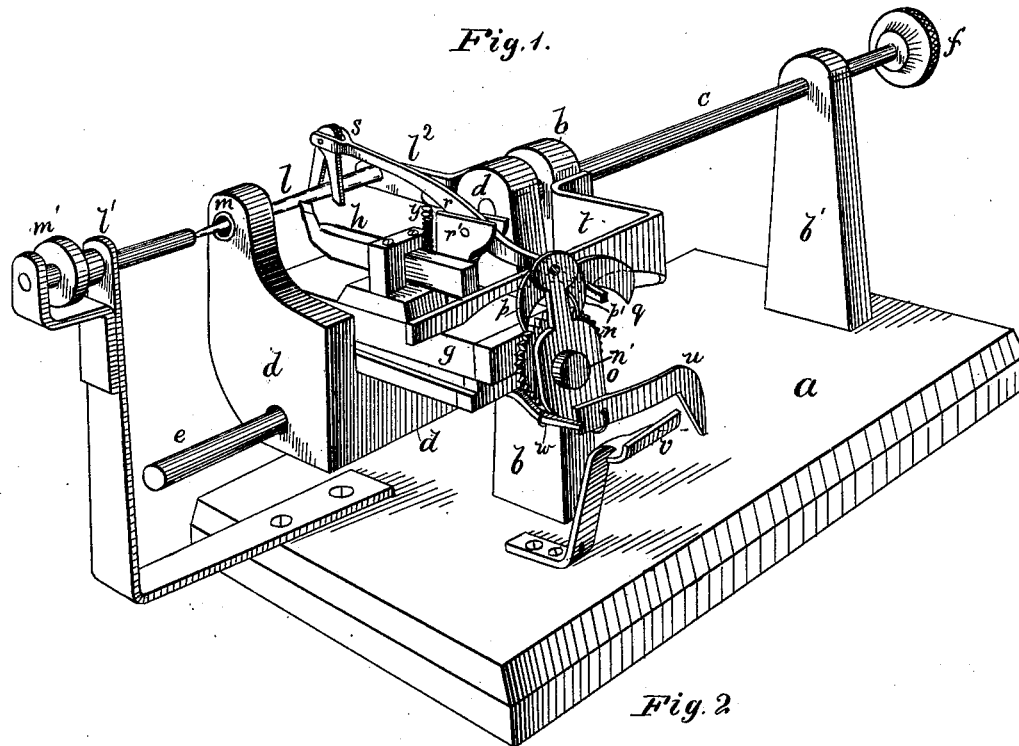

WITNESSES:

Henry N. Miller
C. Sedgwick

INVENTOR:

E. Brown

BY

Munn & Co.

ATTORNEYS.

UNITED STATES PATENT OFFICE.

EBEN BROWN, OF MILFORD, MASSACHUSETTS.

IMPROVEMENT IN MACHINES FOR TURNING NEEDLE-BLANKS.

Specification forming part of Letters Patent No. **208,712**, dated October 8, 1878; application filed June 3, 1878.

To all whom it may concern:

Be it known that I, EBEN BROWN, of Milford, in the county of Worcester and State of Massachusetts, have invented a new and useful Improvement in Turning-Machines, of which the following is a specification:

The object of my invention is to automatically regulate the action of the cutting-tool upon the blank in turning-machines, so that the blank will be cut to the standard gage, and the tendency of the machine to enlarge the needle or other article produced from the blank is corrected by the act of forming such blank.

In the production of sewing-machine needles the blank is turned from wire, the reduction being accomplished by a cutting-tool mounted on a traveling carriage and coming in contact with the revolving wire.

It is of great importance that the blanks turned out by the machine should be strictly uniform in size; but, in consequence of the wear upon the cutting-tool and the devices for holding the wire, there is a constant tendency to enlargement of the blanks as the work proceeds.

My invention consists in mounting a pair of calipers or similar device so as to automatically test the size of the blank as the same is cut, and in arranging the said calipers in connection with the adjusting-screw of the cutting-tool so that the cutting-tool is automatically moved to or from the needle-blank to enlarge or reduce the size of the blank and maintain the desired size, and thereby secure uniformity in the blanks produced.

In the drawings, Figure 1 is a perspective view of my device as applied to a turning-machine for needle-blanks, and Fig. 2 is a plan of the same.

Similar letters of reference indicate corresponding parts.

a represents a bed, having two posts, *b b'*. The bed *a* is to be firmly secured to a lathe-bed in any desired manner, and supports the turning device.

c is a rod passing through the posts *b b'*, and having upon it at one end the head-block *d*. *e* is a second rod, projecting from the post *b* and passing through the bottom of the head-block *d*, to form a slide or way for the head-block *d*.

The head-block *d* is moved to the right and

left by the rod *e*, which can be made to slide through the posts *b b'* either by hand or automatically. The distance which the head-block *d* is moved to the left is regulated by a stop, *f*, upon the rod *e*, where it projects beyond the post *b'*. This distance is the length of the needle-blank to be turned.

The head-block *d* carries the tool-stand *g*, which moves in ways thereon at right angles to the motion of the said head-block *d* upon its rod *e*.

h is the cutting-tool, secured to the tool-stand *g*, and *i* is a spring, serving to hold the tool to the blank. *k* is an adjusting-screw, which, when turned in one direction, draws the tool-stand *g* away from the blank, and when turned in the reverse direction allows the spring *i* to draw the tool-stand *g* and tool *h* toward the blank.

l is the wire-blank, held in bearings *l' l''*, and supported against the pressure of the cutting-tool *h* by a thimble, *m*, which thimble *m* is fixed in a projection from the head-block *d*. The wire *l* is revolved by a pulley, *m'*, in the usual manner, and the tool-carriage is traversed obliquely to the axis of the blank *l*, as shown in Fig. 2.

The adjusting-screw *k* carries at its outer end the ratchet-wheel *n*, keyed thereon; and fulcrumed upon a stud or projection, *n'*, from the wheel *n*, is a lever, *o*. The lever *o* carries at its upper end a double-acting pawl, *p p'*, engaging with the wheel *n*; and *q* is a projection from the pawl *p'*, serving first as a weight, which tends to keep the pawl *p'* in contact with the wheel *n*, and, secondly, for the purpose hereinafter described.

r is a lever upon a fulcrum, *r'*, on the tool-stand *g*. *s* is a pair of calipers upon one end of the lever *r*, which is at a point directly or nearly over the blank *l*, so that the calipers *s* may rest upon the blank *l*. The opposite end of the lever *r* passes under a form, *t*, and beneath the projection *q* upon the pawl *p'*.

u is a projecting arm from the lower end of the lever *o*, which comes in contact with an inclined projection, *v*, on the bed *a* as the head-block moves from right to left, and turns the lever *o*. A spring, *w*, returns the lever to its upright position as soon as the arm *u* is clear of the projection *v*.

The operation of the machine is as follows:

The calipers *s* are adjusted to the desired size for the blank, so that they will rest upon the blank *l* as long as the blank is of the proper size or larger. In case the blank is too large the calipers are held elevated, thus depressing the other end of the lever *r*, retaining it out of contact with the projection or weight *q*, thereby allowing the pawl *p'* to engage with the teeth of the ratchet-wheel *n*, raising the pawl *p* clear of the wheel. By sliding the rod *e* the head-block *d* is moved to the left, and the wire is reduced by the tool *h* to form the blank. As the head-block *d* moves the arm *u* comes in contact with the projection *r* and turns the top of the lever *o* to the left, the pawl *p'* at the same time sliding over the teeth of the wheel *n* as soon as the arm *u* is clear of the projection *r*, which is just before the head-block *d* reaches its extreme position to the left. The spring *w* throws the lever *o* back to its upright position, and the pawl *p'*, being then in contact with the wheel *n*, turns the wheel *n* and screw *k* to the right. The pitch of the screw *k* should be such that this motion will permit the spring *i* to draw the tool *h* nearer to the blank *l* and cause it to cut a deeper chip in its next movement from the right to the left. I have shown the projection *r* inclined at the point where the arm *u* travels over it, so that the movement of the wheel *n* and screw will be made gradually, and not suddenly, as the arm *u* leaves the projection. Upon the return movement of the head-block the arm *u* passes by the side of the projection *r* without affecting the lever *o*. The side of the projection *r* is inclined to the path of the arm *u*, and the arm *u* springs past the projection *r* as the head-block returns to the right. During the passage of the head-block *d* from right to left, as just described, the calipers *s* have moved upon the blank *l* immediately behind the cutting-tool, and the operation of the parts to move the cutting-tool toward the blank, as set forth, is based upon the supposition that the blank has not been reduced to the standard size by the tool, and consequently the calipers have moved over the blank without operating upon the pawls. Now, if the movement of the tool toward the blank by the action of the screw *k*, as just described, has been too great, so that the blank next turned is below the standard size at which the calipers are set, the following action takes place: As soon as the tool *h* has moved far enough to the left to allow the calipers *s* to come upon the freshly-cut portion of the blank *l*, that portion being smaller than the standard, the calipers drop over the blank, as seen in Fig. 1. throwing up the outer end of the lever *r*, which raises the projection *q* and pawl *p'* and throws the pawl *p* into contact with the ratchet-wheel *n*. The spring *y* aids this movement. The tool continues to move to the left, and the arm *u*, as it is raised by the projection *r*, causes the pawl *p* to act upon the wheel *n*, turning it to the left, and consequently turning the screw *k*. This forces

the tool *h* back from the blank against the action of the spring *i*, and enlarges the size of the next blank that is cut, and this operation is repeated until one is produced that will not admit of the calipers passing down over it, and then the projection *q* is relieved by the lever *r*, and the pawl *p'* is allowed to rest upon the ratchet-wheel *n*. In practice the adjusting-screw is seldom acted upon by the pawl *p* to enlarge the size of the blank, and the device is self-adjusting, to prevent any rotation of the adjusting-screw, except when the blank is not of the proper size. The blank in the process of turning is tapered a trifle toward the point throughout its length, and the calipers, at first falling upon the largest portion, will not drop until the pawl *p* has moved without effect in the direction to enlarge the blank, and then the calipers *s*, passing down the taper, will drop and raise the projection *q* just in time to prevent the pawl *p'* acting upon the ratchet-wheel *n* in the direction to reduce the size of the blank as the lever *o* reacts. Thereby the adjusting-screw is not moved in either direction until the wear upon the tool *h* and thimble *m* changes the size of the blank enough to require adjustment. The lever *r* passes under the form *t*, which has the edge next to the lever *r* curved as shown. The office of this form *t* is to raise the calipers by the action of the curved edge of the form *t* upon the lever *r*. This curved edge on the form *t* also prevents the calipers from falling before the proper time.

It may be added that the curved edge of the form *t* is of such shape that the lever *r* is depressed and the calipers *s* raised above the blank when the tool-carrier *g* is at the extreme ends of its traverse; but the calipers *s* are allowed to fall upon the blank between those points.

It will be seen that the size of the needle-blank or other article to be reduced is automatically regulated by the means shown, and the gradual and constant tendency in turning-machines to enlarge the size of the turned blank is corrected, while any liability there may be in the machine to reduce the size below the standard is also corrected.

The details of this device are to be varied to adapt it to the different forms of turning-machines; and I do not limit myself to the construction as set forth, as it may be varied or equivalent devices substituted without departing from the essential features of my invention.

Having thus described my invention, I claim as new and desire to secure by Letters Patent—

1. The combination, with a machine for turning needle-blanks, of means for automatically regulating the size of the blanks produced, consisting of the following elements: a pair of calipers hung upon a lever connected with the tool-carrier in such a position as to bear upon the cut blank, a ratchet-wheel upon the adjusting-screw of the cutting-tool, and

a swinging pawl-carrier provided with two pawls and acted upon by a fixed projection from the bed of the machine to move the ratchet-wheel in one direction or the other, according to the position of the lever which carries the calipers, substantially as described.

2. The adjusting-screw *k*, ratchet-wheel *n*, lever *o*, pawls *p p'*, arm *u*, projection *v*, lever *r*, calipers *s*, and springs *i w y*, combined and arranged with the tool-carrier *g*, substantially as and for the purposes set forth.

3. The arm *u* and inclined projection *v*, for moving the ratchet-lever and allowing the adjusting-screw to be gradually turned, substantially as set forth.

EBEN BROWN.

Witnesses:

LEWIS HAYDEN,
GEORGE G. PARKER.