

V. I. FEENY.
Swingstile Recorder.

No. 208,727.

Patented Oct. 8, 1878.

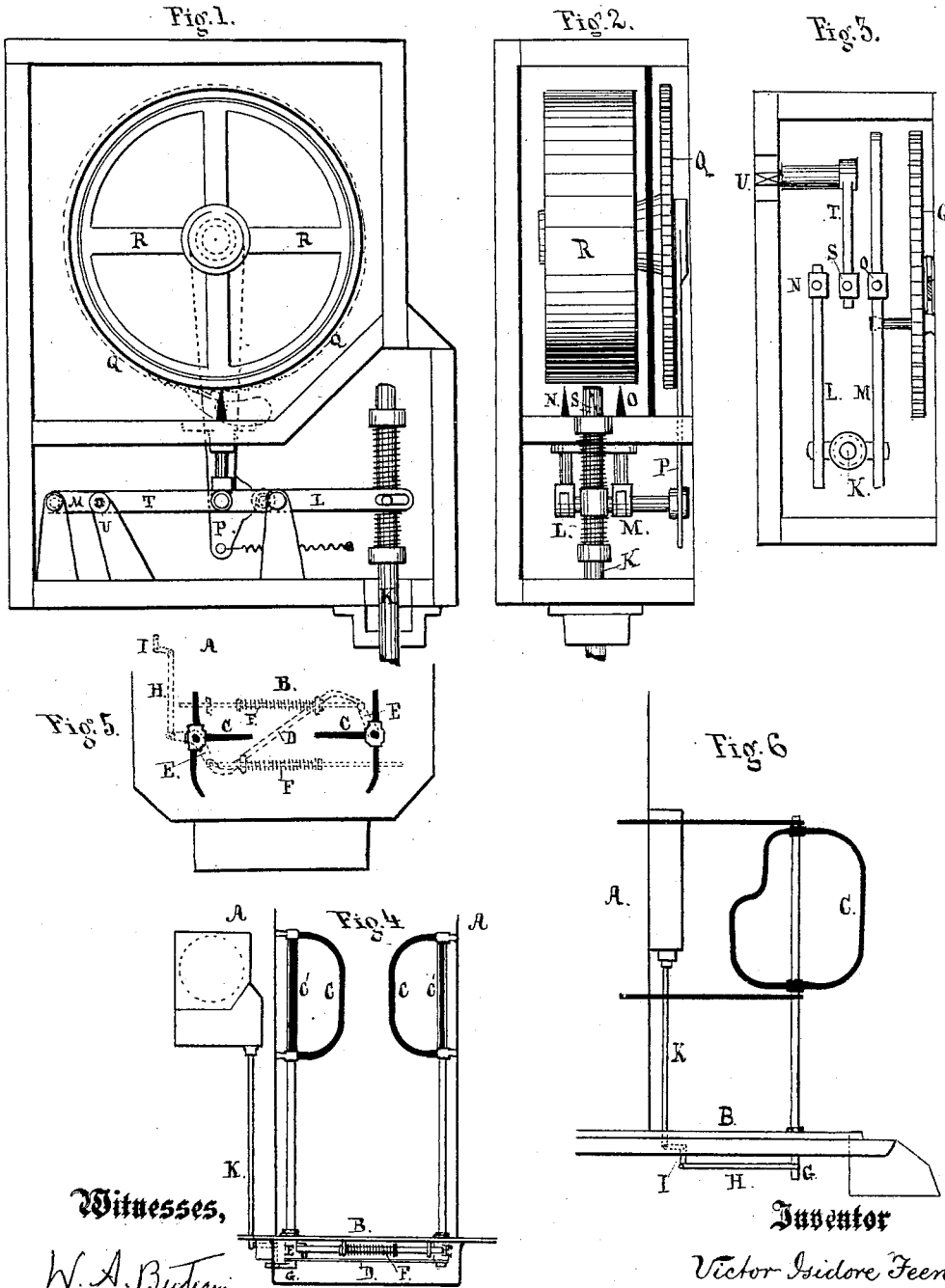

Witnesses,
W. A. Burton,
D. L. H. Barclay.

Inventor
Victor Isidore Feeny.
by
R. W. Williams
Attorney.

UNITED STATES PATENT OFFICE.

VICTOR ISIDORE FEENY, OF BRIXTON, ENGLAND.

IMPROVEMENT IN SWING-STILE RECORDERS.

Specification forming part of Letters Patent No. **208,727**, dated October 8, 1878; application filed September 11, 1877; patented in England, December 14, 1876.

To all whom it may concern:

Be it known that I, VICTOR ISIDORE FEENY, of Brixton, in the county of Surrey and Kingdom of England, have invented certain new and useful improvements in apparatus for registering the number of passengers entering in or upon or leaving conveyances and passages, and the fares or tolls taken, of which the following is a full, clear, and exact description, reference being had to the accompanying drawings, forming part of this specification.

My invention consists in the application of swing doors or stiles in lieu of revolving stiles for operating, registering, or indicating apparatus; also, in the combination of swing-stiles with a particular arrangement of registering apparatus.

I arrange each swing door or stile so that only one person can pass through at the same time, whether in the one direction or the other, one or more arms or projections following the door or stile in its swing backward or forward, and obstructing the passage of a second person until the preceding passenger has passed through and his entrance or exit is registered.

One or more swing-stiles may be used, according to requirement. Where two or more are used I may connect them so that they will work together.

My swing-stiles may be connected to ordinary registering or indicating apparatus by any suitable arrangement of rods or levers or other connecting-gear; but I prefer to use them in combination with the following arrangement of registering or indicating apparatus, which forms part of this invention.

I connect the swing-stiles with a barrel or drum in such manner that the swinging of the stiles in one or other direction will cause the said barrel or drum to revolve, and at the same time to give motion to one of two prickers or markers arranged so as to bear upon a sheet of paper or other material placed upon the circumference or face of the barrel, and register a mark corresponding to the passage of each person through the stiles, one pricker or marker operating on the passage of a passenger in one direction, the other upon a passenger passing in the opposite direction.

I may also arrange the prickers to operate

upon a slip or band of paper of any length passing from one roller to another.

When my registering or indicating apparatus is applied to an omnibus or tramway-car, I may provide it with an additional marker or pricker, to be brought to bear upon the paper carried on the drum or barrel by an attendant provided with a suitable key for the purpose of indicating a break in the journey, whereby the fares paid over each section of the journey are easily ascertained.

In applying my invention to tram-cars into which passengers enter at one end or the other, according to the direction in which the car is traveling, I fix a pair of stiles at each end, or I may use one pair of swing-stiles arranged so that it may be shifted readily from one end of the car to the other and each stile connect itself automatically with the registering apparatus directly it is in position.

The accompanying sheet of drawings shows the details of the indicator drawn to an enlarged scale, Figure 1 showing the arrangement and general construction of the indicator or registering instrument; Fig. 2, a side view of the above, and Fig. 3 a plan of the prickers or markers, and of the levers for actuating the same. Fig. 4 represents an elevation of the back end, or that portion of an omnibus to which my apparatus is fixed, as shown, Fig. 5 being a plan of the same, and Fig. 6 a side view thereof.

Similar letters of reference indicate similar parts in each of the figures, respectively.

A indicates the body of the omnibus; B, a platform securely attached onto the rear end of the same; C C, the swing stiles or doors; C' C', arms following same; D, rod connecting the two stiles beneath the platform; E E, cranks for connecting-rod D; F F, springs for bringing the stiles to their normal position; G, crank for working the indicator; H, connecting-rod communicating motion from the swing-stiles to the indicator; I, bell-crank; K, tappet-rod; L M, levers for working prickers or markers; N O, the prickers or markers; P, lever for driving drum or barrel; Q, ratchet-wheel; R, drum or barrel; S, supplementary pricker. This pricker may be fitted with a spring to bring it back after operating. T, lever for raising same to bear upon the face of the drum or barrel;

U, stud for key. The turning of this stud with the key actuates the lever T, and thereby the pricker S.

The action is as follows: Immediately upon a passenger entering or passing through the stiles C C the tappet-rod K is caused, by means of the crank G, connecting-rod H, and bell-crank I, to move in a downward direction, carrying with it the two levers L M, whereby the pricker N is raised so as to pierce the strip or band of paper previously placed upon the drum R, while at the same time, owing to the manner in which the levers are hung, the pricker O is withdrawn from the same.

Should the stiles C C be moved in an opposite direction to that above described, the tappet-rod K and levers L M are also moved in a corresponding direction, when the pricker O is made to enter the drum in lieu of the pricker N.

When it is required to register any change or alteration in addition to the above registration—such, for instance, as the various fares in any public conveyance—an attendant, provided with a suitable key and stationed on the spot where an alteration of fare is made, turns the stud U, and so causes the supplementary pricker S to pierce the paper, by which means any number of breaks or alterations can readily be registered.

The barrel or drum carrying the strip or band of paper upon which the registering or indicating marks or perforations are made is inclosed,

so as to be accessible only to the person authorized to remove the said paper at the end of each journey, at the end of the day, or when desired.

The total amount of money taken for fares during each journey may be readily calculated, as follows: Having first ascertained from the perforations upon the strip or band of paper the total number of passengers who have entered the omnibus during each section or division of the journey, the same are charged as if they had traveled from that section to the end of the journey. The number of exits recorded are also charged in like manner, less an amount of fare corresponding to one portion or section of the journey. This latter amount being deducted from the former gives the total fares received during the journey.

What I claim as new, and desire to secure by Letters Patent, is—

1. In combination with the swing-stiles C C, the rod D, cranks E E, prickers or markers N O, and intermediate actuating mechanism, substantially as set forth.

2. In combination with the stiles C, having follower C', the connecting-rod H, bell-crank I, tappet-rod K, levers L M, prickers N O, and drum R, substantially as described.

VICTOR ISIDORE FEENY.

Witnesses:

HENRY STEPHEN HOLMES PEYLER,
THOS. RIDGE.