

A. BORNEMAN & J. A. SHEPHARD.
Feed-Cutter.

No. 208,786.

Patented Oct. 8, 1878.

Fig 1

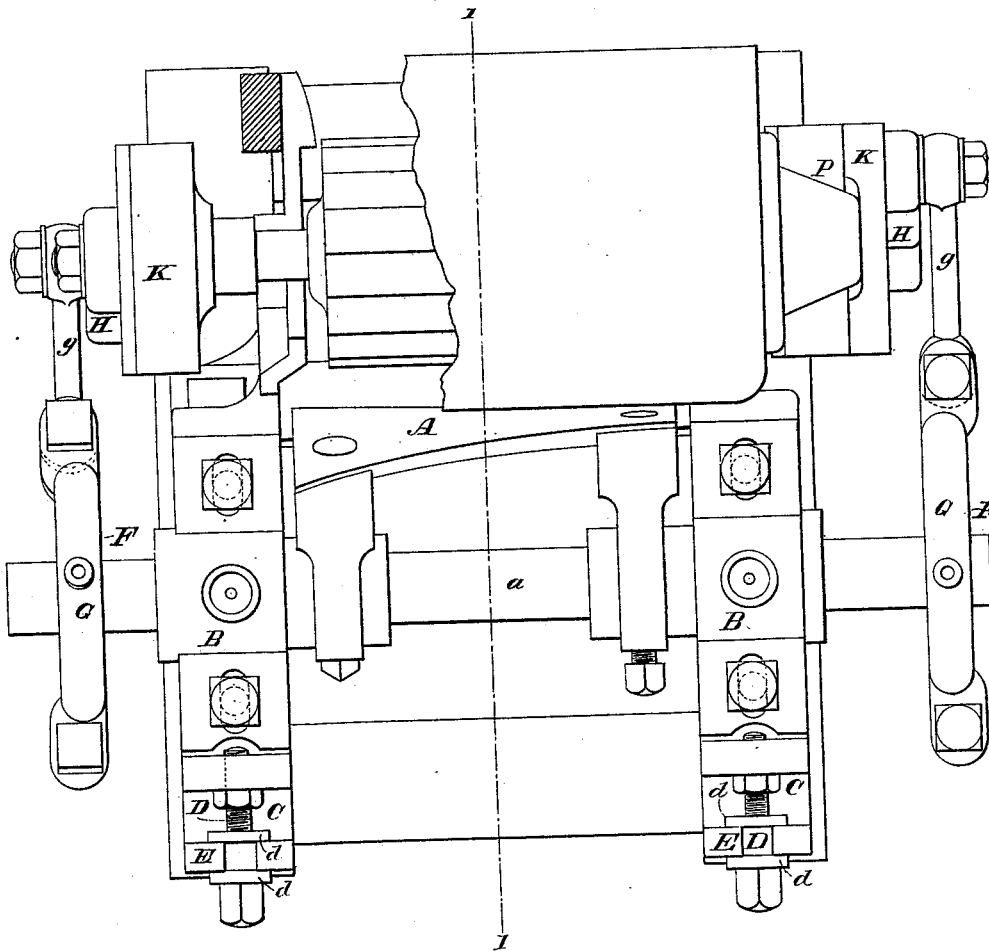

WITNESSES

Wm A. Kinckle
J. Stick

INVENTORS

August Borneman
By their Attorneys, *Joseph A. Shephard*
Baldwin, Hopkins, & Peyton.

A. BORNEMAN & J. A. SHEPHARD.

Feed-Cutter.

No. 208,786.

Patented Oct. 8, 1878.

Fig 2

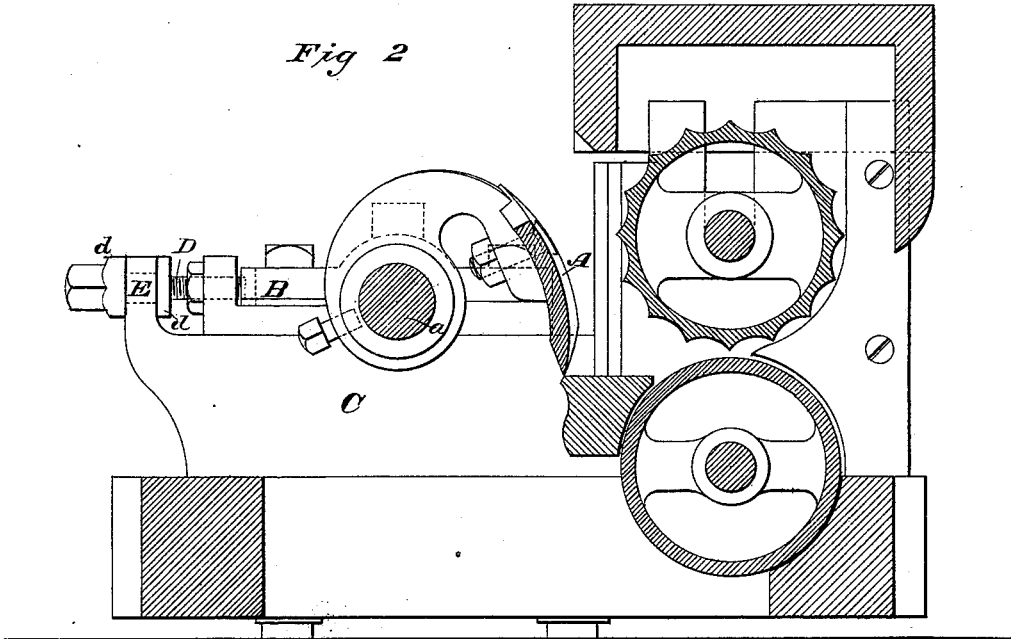
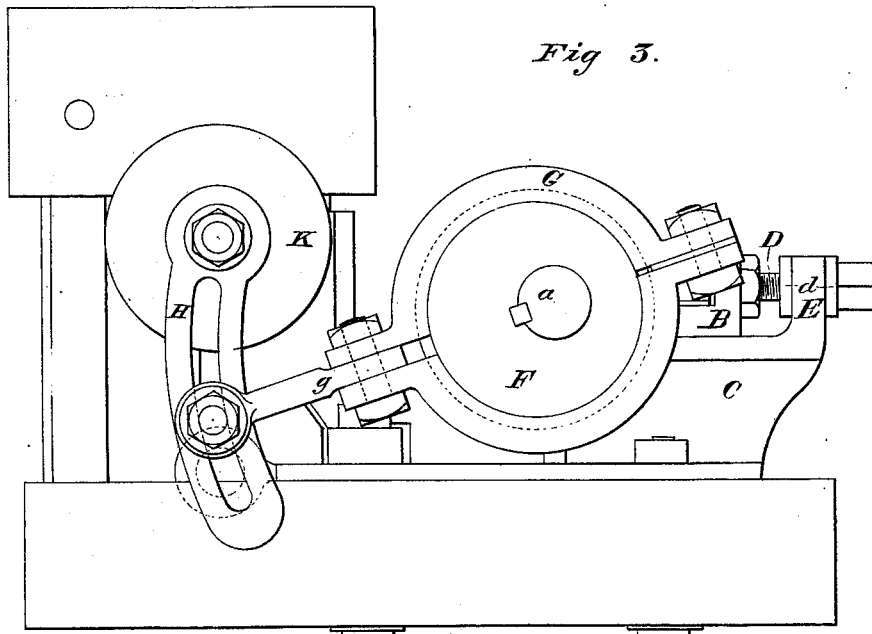

Fig 3.



WITNESSES

Wm A Stanley
J. Fish

INVENTORS

August Borneman.

By their Attorneys, Joseph A. Shephard,
Baldwin, Hopkins, & Peyton

A. BORNEMAN & J. A. SHEPHARD.

Feed-Cutter.

No. 208,786.

Patented Oct. 8, 1878.

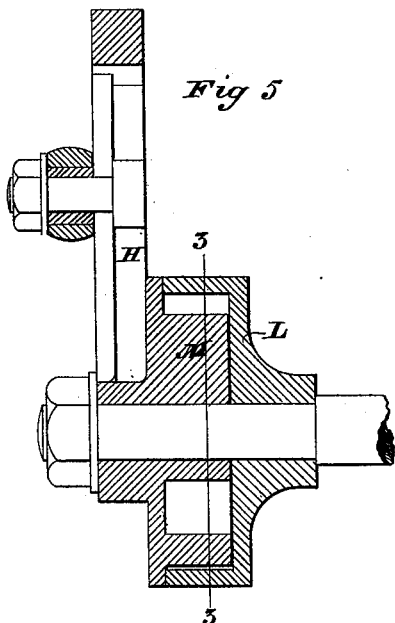
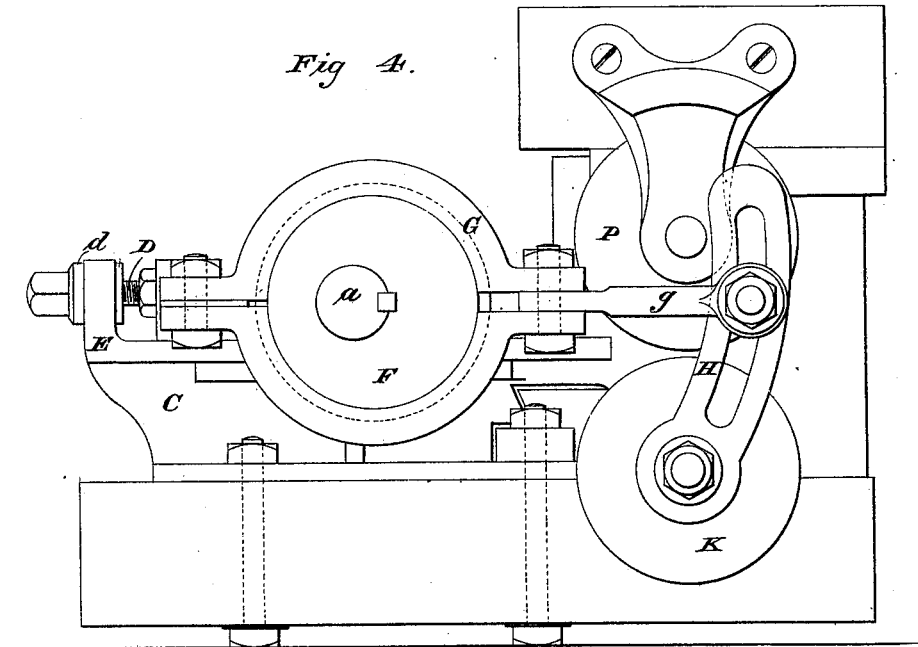
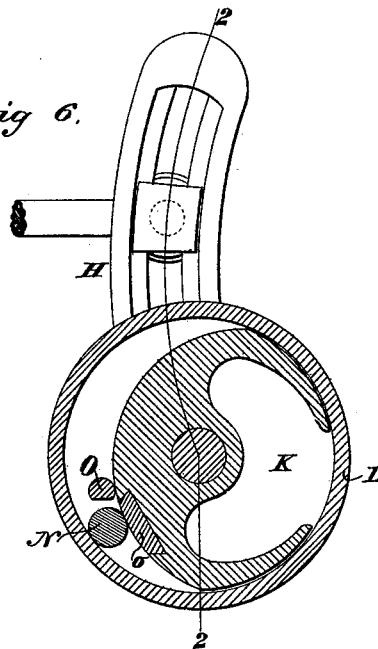

Fig 6.



WITNESSES

*Wm A Skinkle
J. Cook*

INVENTORS

August Borneman.

*By their Attorneys, Joseph A Shephard,
Baldwin, Hopkins, & Peyton*

UNITED STATES PATENT OFFICE.

AUGUST BORNEMAN AND JOSEPH A. SHEPHARD, OF LANCASTER, OHIO,
ASSIGNORS TO HOCKING VALLEY MANUFACTURING COMPANY, OF
SAME PLACE.

IMPROVEMENT IN FEED-CUTTERS.

Specification forming part of Letters Patent No. **208,786**, dated October 8, 1878; application filed
January 26, 1878.

To all whom it may concern:

Be it known that we, AUGUST BORNEMAN and JOSEPH A. SHEPHARD, both of Lancaster, in the county of Fairfield and State of Ohio, have invented certain new and useful Improvements in Feed-Cutters, of which the following is a specification, that by reference to the accompanying drawings will enable those skilled in the art to which our improvements relate to make and use the same.

The objects of our invention are to advantageously accomplish and properly regulate the feeding of the material to be cut, and to readily and accurately adjust the cutter to the cutter-plate, either when it is in operation or at rest.

The means by which we accomplish these objects are hereinafter specifically designated and claimed.

In the accompanying drawings, Figure 1 is a plan view, partly in section, of our improved feed-cutter. Fig. 2 is a section through the line 1 1 of Fig. 1. Fig. 3 is a side elevation, showing the connection between the cutter-shaft and the upper feed-roll. Fig. 4 is an opposite side elevation, showing the connection between the cutter-shaft and the lower feed-roll. Fig. 5 is a sectional view of a friction-clutch and slotted arm for operating the feed-rolls on the line 2 2 of Fig. 6, which is a similar view on the line 3 3 of Fig. 5.

A indicates the rotary cutter, with its shaft *a* resting in adjustable boxes or bearings B, supported by suitable castings C. The set-screws D D, provided with rigid collars *d d*, pass through slotted lugs E E on the castings C and enter female screws in the boxes, and serve to properly adjust the respective ends of the cutter forward and back with reference to the cutter-plate, either when the cutter is in operation or at rest. The cutter-shaft projects through its bearings on each side, and carries two eccentrics, F F, which, by means of the eccentric straps G G and rods *g g*, communicate a reciprocating oscillatory motion to the slotted arms H H, attached respectively to friction-clutches K K applied at opposite ends, one to the upper and the other to the lower feed-roll. These friction-clutches consist of

hollow pulleys L, open on one side, and secured rigidly on projections of the shafts of the respective feed-rolls. Within these hollow pulleys are inserted cams M M, fitting loosely on the projections of the feed-roll shafts, and attached to or cast in one piece with the slotted arms H H. Between these cams and the interior peripheries of the hollow pulleys are friction-rollers N, each held in place by a stop-pin, O.

In order to present a better frictional bearing-surface for the friction-rollers small plates of steel *o* are secured in dovetailed recesses in the faces of the cams. These steel plates, like the friction-rollers, can be readily removed and replaced should they become worn, which, however, they are not liable to.

The friction-clutches are applied to the feed-rolls, so as to revolve them intermittently in the usual manner in opposite directions to draw the feed forward to receive the blows of the cutter. It will be noted that the friction-clutches are opposite, or rights and lefts, carrying their friction-rollers in such positions, respectively, that gravity keeps them constantly in the bite of the hollow pulleys and cams, so that the clutching shall always be instantaneous upon the change of direction of the slotted arms. An extra stationary friction-clutch, P, not provided with a slotted arm, is attached to the opposite end of the upper feed-roll shaft, so as to clutch in the opposite direction from that which causes the feeding, to counteract any tendency of that roll (which is usually corrugated longitudinally) to back.

From the foregoing description of the construction of our feed-cutter it will be obvious that its operation is as follows: The cutter being properly adjusted to the cutter-plate, and the eccentrics F F being properly set with respect to the cutter, their action will rock the slotted arms H H, which will cause the friction-clutches K K to intermittently rotate the feed-rolls at the proper times to advance the feed between the rolls to the cutter.

The points of connection of the rods *g g* to the slotted arms H H may be altered at will to increase or diminish the extent of revolution of the feed-rolls at each throw, and thus regu-

late the feeding, not confining ourselves to the precise details of construction herein set forth, which might be varied without departing from our invention.

What we claim as new, and desire to secure by Letters Patent, is—

1. The combination of the rotary adjustable cutter, the eccentrics on the cutter-shaft, the rocking-arms connected with the eccentrics, the friction-clutches, and the feed-rolls, substantially as and for the purposes specified.

2. The combination of the hollow open pulley,

the friction-roller, and the recessed cam, provided with a steel friction-plate and a rocking arm, substantially as and for the purpose specified.

In testimony whereof we have hereunto subscribed our names.

AUG. BORNEMAN.
JOSEPH A. SHEPHARD.

Witnesses:

H. A. UTILHOFF,
JAMES DAVIDSON.