

W. J. BROWN, Jr.
 Machine for Inserting and Clinching Wire Staples.
 No. 208,789. Patented Oct. 8, 1878.

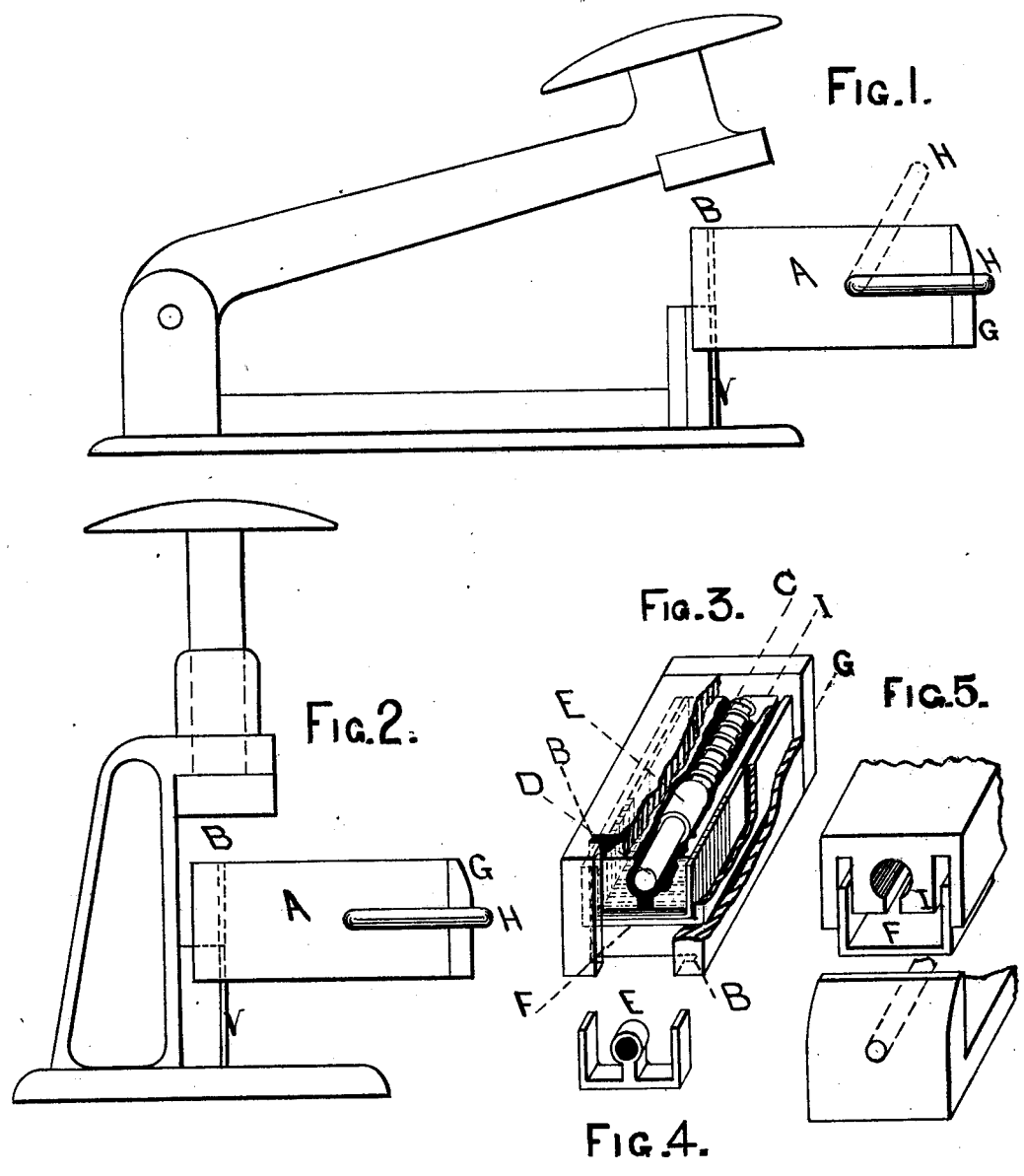

WITNESSES.
William A Tompkins
Edwin A Keyfe

INVENTOR.
William J. Brown Jr.

UNITED STATES PATENT OFFICE.

WILLIAM J. BROWN, JR., OF PHILADELPHIA, PENNSYLVANIA.

IMPROVEMENT IN MACHINES FOR INSERTING AND CLINCHING WIRE STAPLES.

Specification forming part of Letters Patent No. **208,789**, dated October 8, 1878; application filed June 18, 1878.

To all whom it may concern:

Be it known that I, WILLIAM J. BROWN, JR., of the city and county of Philadelphia, and State of Pennsylvania, have invented a new and useful Improvement in Machines for Inserting and Clinching Metallic Staples, which improvement is fully set forth in the following specification and accompanying drawings, in which—

Figures 1 and 2 are side elevations of paper-fasteners, showing my improvement attached. Fig. 3 is a perspective view, with parts of the outer shell broken away to exhibit the interior portions. Fig. 4 is a detached part, so shown for greater clearness. Fig. 5 is another manner in which my improvement may be constructed.

Similar letters of-reference indicate corresponding parts in the several figures.

This invention relates to certain improvements in machines operated by hand for inserting and clinching metallic staples through several thicknesses of paper or other material, by means of which a simple and efficient device is produced for holding a series of staples and automatically feeding them forward as required.

The invention consists, primarily, in a separable oblong guide-block, within which are contained the staples *en train* or procession, and the several devices for holding them in position and propelling them forward for insertion in the material to be fastened. At the front end of the block are vertical grooves, which receive and guide the staples down to the work on the descent of a lever-arm or plunger. The rear end of the block is closed by a cap secured in position by a pivoted latch, said cap serving to hold the interior parts in position and prevent their accidental displacement. Within this block is a mandrel, which loosely fits the concave part of the staples and holds them down in position. Said mandrel is recessed on each side of its whole length to receive the side walls of a sheath, which slides therein and guides the staples. The mandrel is also recessed in its center for the reception of a guide-rod, carrying a spiral spring and follower, for operating upon the staples at the rear of the series, and propelling them forward toward

and into the guiding-grooves at the front of the block as they are required to be used.

Referring to the drawings, A represents the guide-block, having at one end grooves B B, by which the staples are sustained while being driven, and within which slides the anvil-plate V of the paper-fastening hand-stamp. Upon the top surface or flat face of the anvil the clinching of the staples may be completed by their pressure thereon. I represents a mandrel, which fits loosely in the concave part of the staples, and acts as a means of preventing them from rising out of position while being pushed forward by a pressure upon the rear one in the train. D represents a guide-rod, which is suspended in a recess in the mandrel I, and operates to confine the spiral spring C in place, as well as to carry the follower E, which slides along upon the rod and pushes the staples forward as required. F represents a sheath having its interior walls smooth and true, to act as a magazine and guide for the staples. G is the cap or closing piece for the end of the guide-block A, and to it is secured the end of the guide-rod D. The cap-piece is secured in place by the latch H.

The operation is as follows: Having placed a desired quantity of staples within the sheath F, with the points upward, place upon them the mandrel I, with follower E in position behind the staples. Then insert in the recess of the mandrel I the rod D, carrying the spiral spring C, press down the cap-piece G, and fasten with the latch H. The first staple of the train will be found in its proper position within the grooves B B, and upon sliding the grooves upon the anvil-plate of the paper-fastening hand-stamp until the back or crown of the staple rests upon the top of the anvil-plate the staple may be driven through the stock desired to be fastened. As the guide-block descends the anvil-plate, sliding up through the groove, prevents staple No. 2 from coming forward; but upon the block being raised, by the hand or other means, to a sufficient height, the staple will spring forward to its position, and this will be effected repeatedly until the supply of staples is exhausted.

Having thus described my invention, what I

claim as new, and desire to secure by Letters Patent, is—

1. The separable oblong guide-block A, having at its front end the staple-guiding grooves B B, and at its rear end a cap or closing piece, G, and pivoted latch H, for securing said cap in position, substantially as set forth.

2. The combination, with the separable oblong guide-block A, of the sheath F, for guiding a series of staples arranged *en train*, and having its walls parallel and adapted to slide within the recesses at each side of the mandrel, as set forth.

3. The mandrel I, loosely fitting the concave part of the staples, and adapted to hold them down, as explained, said mandrel being recessed on each side of its whole length for the reception of the sheath F, and also recessed in the center for the reception of guide-rod D,

spiral spring C, coiled upon said rod, and follower E, said spring and follower operating directly at the rear of the staples, and propelling them forward in advance of the propelling devices, as and for the purpose set forth.

4. The combination, with the separable guide-block A, having staple-guiding grooves B, cap G, and latch H, of the sheath F, mandrel I, adapted to fit and hold the staples in proper position, guide-rod D, and spiral spring C, operating through central recess in said mandrel, and the follower E, arranged to slide upon the guide-rod, all substantially as shown and described.

WILLIAM J. BROWN, JR.

Witnesses:

STANISLAUS REMAK,
WILLIAM A. TOMPKINS.