

W. F. BROWNE. Steam-Generator.

No. 208,790.

Patented Oct. 8, 1878.

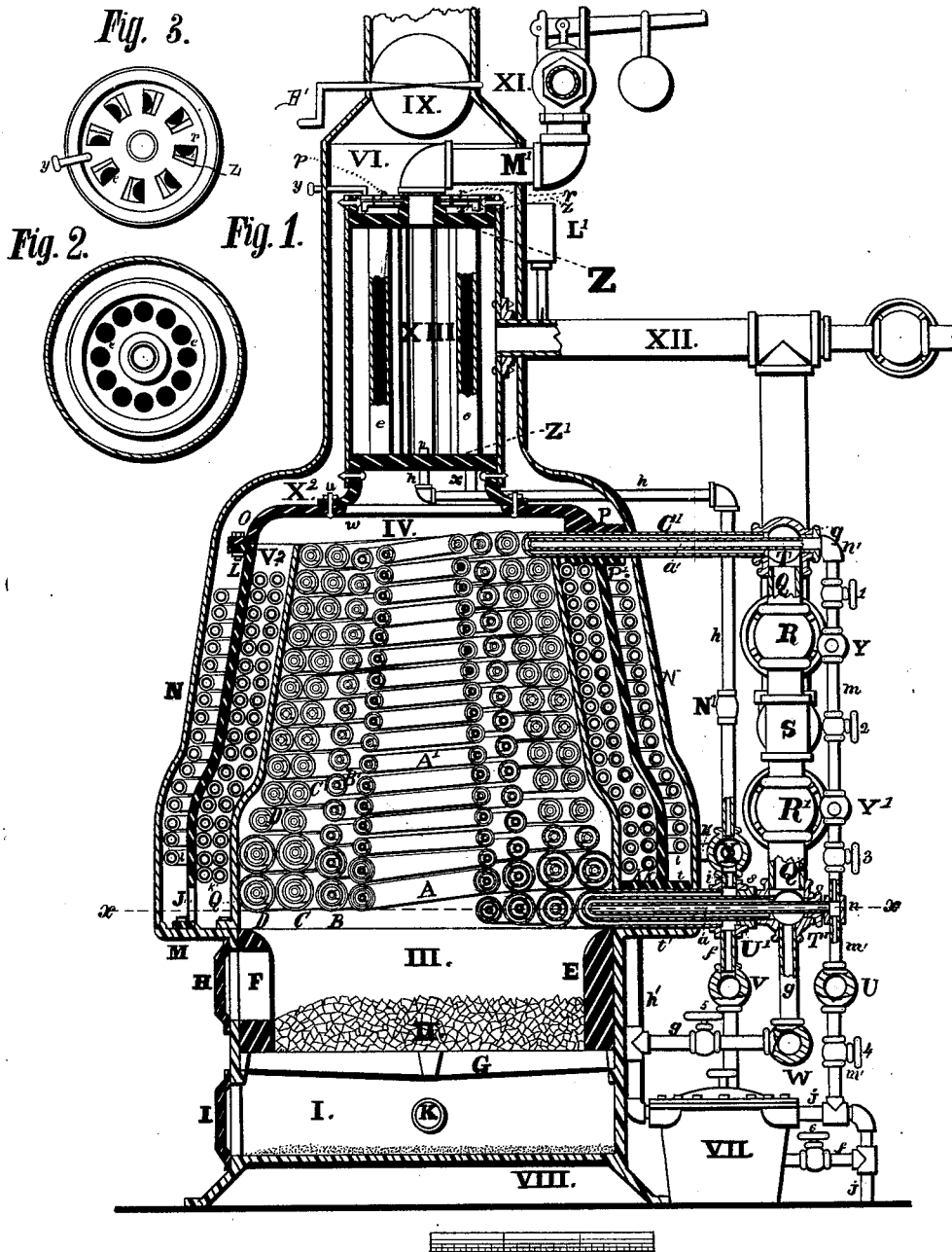

WITNESSES
Henry L. Sayer,
Mark B. Davis

INVENTOR
Wm. Frank Browne.

W. F. BROWNE.
Steam-Generator.

No. 208,790.

Patented Oct. 8, 1878.

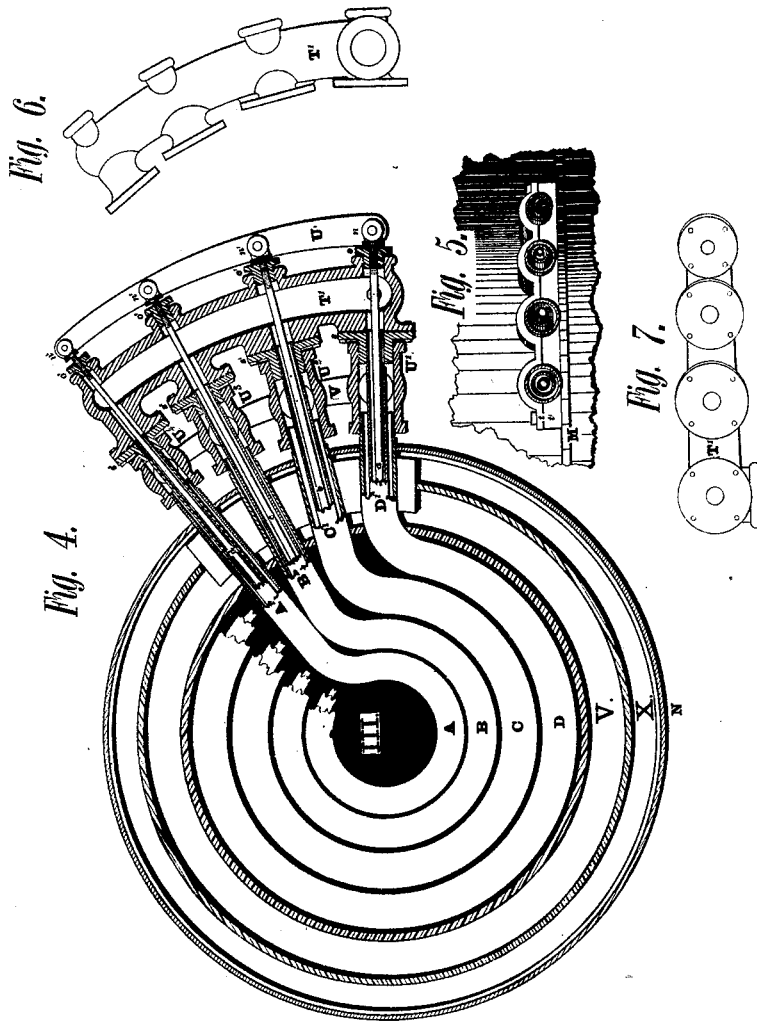

Witnesses
Henry L. Dyer
Mark B. Davis

Inventor
Wm^m Frank Browne

W. F. BROWNE.
Steam-Generator.

No. 208,790.

Patented Oct. 8, 1878.

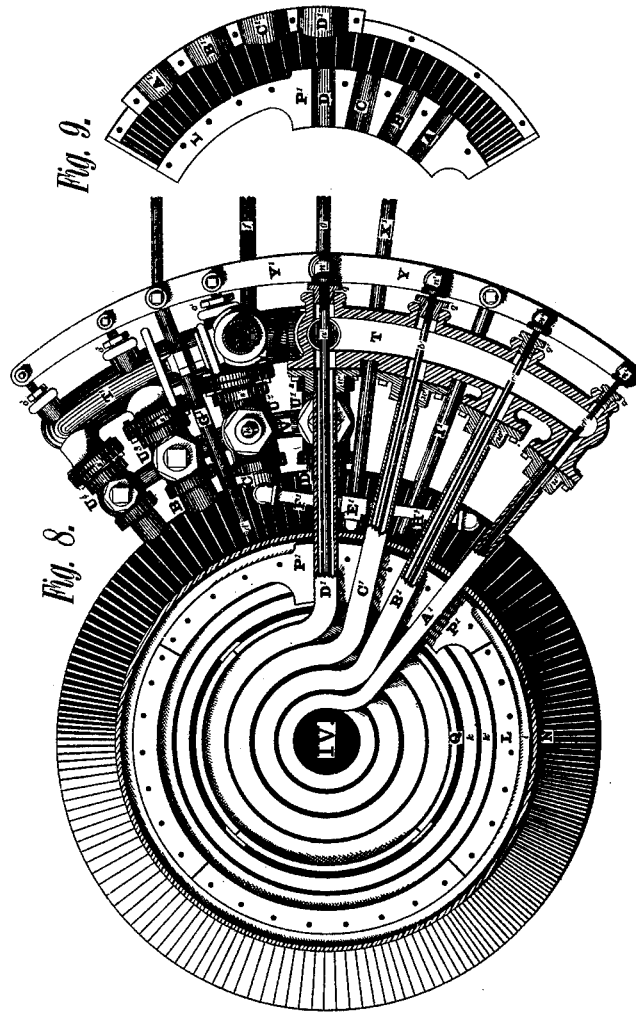

Witnesses
Henry L. Ryan
Mark B. Davis.

Inventor
Wm Frank Browne

W. F. BROWNE.
Steam-Generator.

No. 208,790.

Patented Oct. 8, 1878.

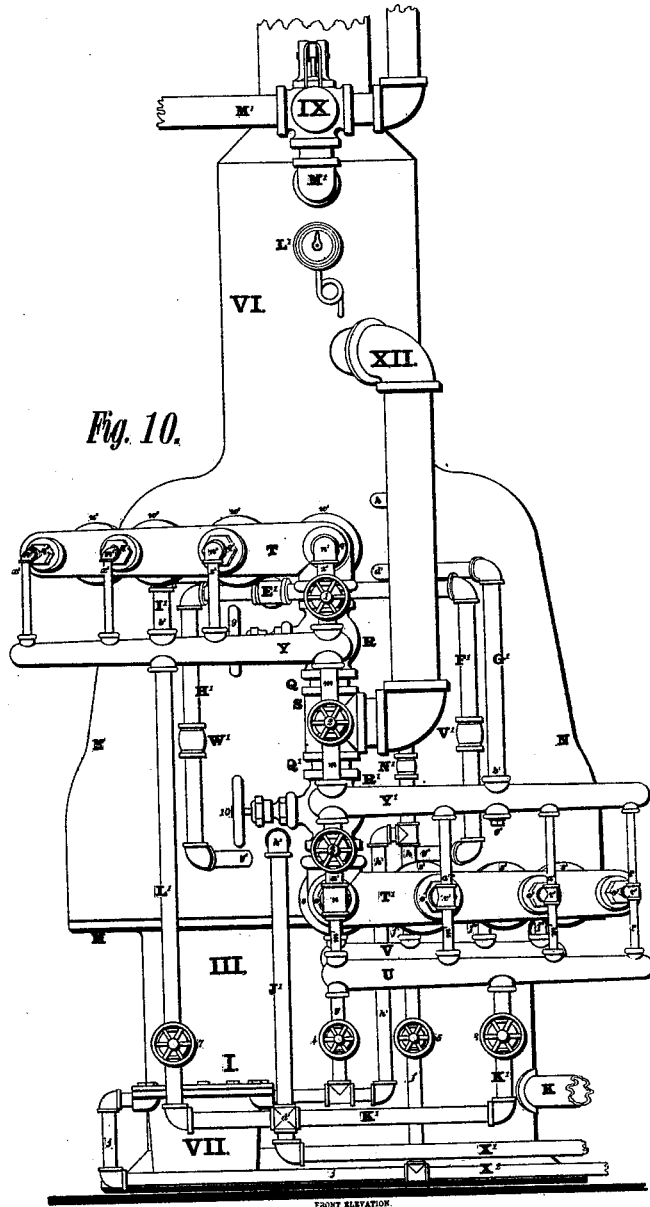

Fig. 10.

FRONT ELEVATION.

Witnesses

Henry L. Dyer,
Clark B. Davis.

Inventor
Wm Frank Browne

UNITED STATES PATENT OFFICE.

WILLIAM FRANK BROWNE, OF NEW YORK, N. Y., ASSIGNOR TO HYDRO
CARBON STEAM GENERATING COMPANY, OF SAME PLACE.

IMPROVEMENT IN STEAM-GENERATORS.

Specification forming part of Letters Patent No. **208,790**, dated October 8, 1878; application filed
December 3, 1877.

To all whom it may concern:

Be it known that I, WM. FRANK BROWNE, of the city, county, and State of New York, have invented some new and useful Improvements in Steam-Generators; and I do hereby declare the following specifications and drawings to be a full, clear, and exact description and representation thereof.

Similar letters, figures, and signs refer to corresponding parts in all of the diagrams.

Figure 1 represents a vertical section of the drum, boiler, fire-box, and ash-pit of a steam-generating apparatus; also a section of some of the water and steam connections, as seen at the right of the figure.

VIII indicates the base of the apparatus, I being the ash-pit above, and K a tuyere-pipe for the admission of air therein, which rises through the grate G and coal II to the fire-box or combustion-chamber III. E represents a fire-clay lining, and F an aperture therein, covered by the door H.

M M is a rim or flange, preferably cast with that portion of the apparatus constituting the furnace, ash-pit, and base. This portion is most easily made of cast-iron, although boiler-plate or other suitable material can be substituted. Upon the rim M projections or vertical flanges, annular or partly so, may be cast or otherwise secured thereto, for the purpose of guides, against which the staves or sectors L Q and outer case, N, are placed. These projecting flanges determine the width of the annular flues formed by the staves and outer case.

J represents an opening in the partition L. Through a series of these openings the draft and heat escape to the outer flue.

The partition staves or sectors Q are provided with a flange at their lower ends. These flanges are bolted to the rim M, thus forming a complete cylinder. The top of this cylinder can be held together by a hoop, or an equivalent device.

The partition L is provided with a flange both at its top and bottom ends, the bottom flange being secured to the rim M, while the top is firmly secured by a flange projecting from a curved rim or ring, O. The partition-walls L are provided with openings J, communicating with flues V and X.

IV is a hot-air chamber, filled with steam-generating coils A A', B B', C C', and D D'. Flue V² contains hot-water coils k k', while flue X² contains cold-water coil l. VI represents a flue or steam-drum chamber, in which the drum XIII is located.

Z Z' are the heads of the drum. c c are its flues. The pipe h is to take the condensation from the steam-drum and conduct it away. r and z represent the section of a damper which rests upon the drum-head Z. p indicates the openings within said damper, and y a handle opening and closing the same. M' is a steam-education pipe, which conducts the steam from the drum XI, being a safety-valve in connection with the same.

IX is a damper for regulating the draft to the furnace. I' represents a steam-pressure gage. XII is a steam education and induction pipe, leading from the steam-generating coils A A', &c., to the steam-drum. R and R' are valves controlling the flow of steam on its passage from the steam-coils to the drum, also to control the action of the steam within the coils A A', &c.

S is a T, its run being vertical and communicating with the top and bottom of the steam-coils A A', &c., while its outlet discharges into the steam-pipe XII.

Q and Q' are nipples connecting the valves R and R' with the combination quadruple T-flanged union-connection T and T', which connect with the steam-coils A' B' C' D'. g is a pipe connected to the lower outlet of the cross T', for conducting the condensation from steam-pipes and unconverted water within the steam-coils A' B' C' D' to the quadruple L-connection W.

On opening valve 5 the water escapes through the horizontal pipe g to the pipe h', thence to the trap VII, whence it becomes discharged through the pipe j.

Y Y' represent a section of two quadruple unions, into which water is injected previous to its delivery into the steam-generating coils A A' B B', &c. The delivery is effected through the stand-pipe m and its connecting-valves 1, 2, and 3; also, connecting L n¹ and T n. The L n¹ and T n are connected to the opposite ends of an internal spray-pipe, a¹ and a, through which the water passes, and is

sprayed from and into the surrounding coils A A' B B', &c.

U is a quadruple L and union-connection, which is connected by means of the nipple m^1 to a series of connecting T's, or their equivalents, for the purpose of conducting water from and blowing off the internal spray-pipes $a a^1 b b^1 c c^1 d d^1$. (See Fig. 10.) In order to blow off these spray-pipes, valve 4 must be opened, thus allowing the water to pass off through the pipes $m^1 j$.

o represents one of a series of bushings, forming a connection between the series of spray-pipes and the combination quadruple T and flange-union.

The regulation threads are cut upon and within their respective parts. Therefore, as the thread cut upon the spray-pipe and within its counterpart within the bushing is finer than the thread upon the circumference of the bushing, it will be necessary to turn the bushing onto the spray-pipe until the end of the spray-pipe projects through the bushing, after which the bushing can be turned into the connection T'. While the bushing is being turned into the connection T' the ends of the spray-pipes advance beyond the face of the bushing sufficiently to form a nipple to receive the connecting L n^1 and T n , &c.

I am aware that other devices may or can be employed to effect or accomplish a similar purpose or object.

U¹ represents a series of crosses, which are connected to a corresponding series of water-boiler coils, A B C D, which are external pipes surrounding the steam-generating pipes A' B' C' D'. These water-coils are constructed as shown, and may be in contact with the fire, as represented in the figure. These water-coils are welded or otherwise connected to the steam-coils by a tapering connection. The space between the steam-coils A' B', &c., should be sufficient to allow a free circulation of water; also, to blow out whatever scale or sedimentary deposit may accumulate within said space. The space need not necessarily be above one-half inch between the inside of the outer pipe and outside of the inner pipe to accomplish the purposes above stated.

V represents an L-union connection beneath the series of crosses U¹, &c. This L-union is connected to the crosses by the nipple f .

In order to blow off and draw the water from the water-coils, open valve 6, and the water will run off through the waste-pipe j .

s is a bushing, which represents a series, and connects the lower ends of the steam-coils with the series of crosses U¹, &c. The steam-pipes project through far enough to form a close nipple to receive a flanged bushing, as shown in Fig. 4.

X² represents a reservoir for water, which is intended to feed the water-coils A B C D by means of their connecting-pipes i . The water in this reservoir should not be at a greater level than the limited water-line in the coils. At that level an overflow must be

provided for, so as to prevent an overflow into the steam-coils. Should the water flow over into the steam coils it would pass off through the connection W to the trap; but when the overflow is in the reservoir X the water will be trapped off by pipe h' .

In order to prevent any undue overflow of water from the reservoir, which might be occasioned by the great pressure within the steam-coils, I connect the pipe h , leading from the bottom of the steam-drum, with the reservoir, for the purpose of equalizing the pressure within said reservoir. It is not necessary that the pipe h should connect with the bottom of the drum, as shown, as steam taken from any other part of the apparatus will accomplish the same purpose; but when applied to the bottom of the drum, it will conduct all of the condensation from said drum to said reservoir, where it will escape through the overflow and pass off through the trap. But if there is a scarcity of water within the water-coils, occasioned by its conversion into steam, said condensation from the drum will assist in supplying the deficiency, and, being already at the boiling-point, it will require but a few additional degrees of heat to complete its conversion.

The reservoir and overflow, as shown in Fig. 1, appear at a higher level than the water within the water-coils. Consequently, as shown, it cannot be operated as described, although the principle is correct. For a better arrangement and description of this principle, see Fig. 10.

Fig. 2 represents a top plan of the tubular steam-drum, c being the flues through which the heat escapes. Fig. 3 represents a damper, shown in Fig. 1 as placed on the drum-head. z is the base or stationary part of said damper, while p is the movable part. This damper is held in position by the nipple which connects the drum-head with the L, as shown in the figure. The damper, when closed, prevents the heated current from entering the stack by way of the flues, and causes the current to pass downward through the annular flue V, whence it escapes through the openings J and rises through the annular flue X, whence it passes upward through an annular flue surrounding the drum, thence escaping through the stack. I located the drum in the position shown for the purpose of avoiding the condensing-surface which it would possess were it exposed to an ever-varying temperature of heat-absorbing atmosphere. The heat derived from the source above mentioned would be lost were it not so utilized. Consequently what is saved at this point is a saving upon the grate. The tubes $e e$ also assist in keeping the steam at a high temperature, and assist very materially in converting the aqueous particles which may or will pass into the drum by the action of the steam-current.

Steam generated in a spiral boiler will force out a part of the water which was forced in. This water is carried by the action of the steam

into the drum, where it separates from the steam and accumulates in the bottom of the drum; and unless a trap or its equivalent is employed to convey the condensation away, the drum soon fills with water, next the pipes, and lastly the boiler, which destroys the steam-producing capacity of the boiler until the water is removed.

To obviate the difficulty of flooding the drum, a trap has been heretofore employed, while, if the arrangement of the drum had been such as I have shown the trap would not have been so serviceable; but all of the difficulties to be encountered do not exist within the drum, for I am aware that spiral boilers have been and are being constructed in such a manner that they give the operator a great deal of trouble.

In ordinary coil boilers the variableness of the steam-pressure does not depend wholly upon the heat. Even if the heat did not vary a degree during ten hours, the indicator would still fluctuate, because that long continuous coil cannot be kept at an even degree of heat so long as cold water is being injected into one of its ends and steam taken out at the other.

Now, when steam passes over an alternating and heat-varying surface, such as a spiral pipe will afford, it suddenly expands and contracts, according to the intensity of the heat through which it passes. Therefore when the steam passes over an intensely-heated surface, a sudden expansion occurs, and a check is given to the injector, the indicator records a high pressure. Now, during this check of the injector or pump the steam has escaped through the safety or motor. Consequently the pressure has decreased, and the injector is again set in motion, and is now forcing more water into the boiler, and will continue to until a fresh supply of steam arrives at the superheating-point, when the above-described action is again repeated.

Now, the object I have in view is to introduce new features, so as to make the apparatus more perfect as regards its mechanical construction, durability, steam-generating capacity, and economy in fuel, which will be fully set forth in the description of the operations and advantages of my invention.

Fig. 4 is a horizontal sectional plan view of a steam-generating apparatus. This section cuts through the outer case, N, and the two portions forming the flues X² and V² on a plane with the bottom coils, or the water-coils at *x x*, Fig. 1.

III indicates the combustion chamber, while A B C D represent coils within said chamber. These coils are broken, so that the ends of each set are shown. The ends projecting from the furnace are represented in section for the purpose of affording a better view of the construction.

The crosses U¹ U² U³ U⁴ are also in section, and are connected to the water-pipes A B, &c. The flange-unions *s s*¹ *s s*² *s s*³ are connected with their respective crosses U¹, &c., and steam-

generating pipes A¹ B¹, &c. Also their flanges are bolted to corresponding flanges upon the combination quadruple T-flanged union T'. Packing should be placed between the two flanges.

*o o*¹ *o o*² *o o*³ represent bushings, which secure the ends of the internal spray-pipes *a b c d*. *n n*¹ *n n*² *n n*⁴ are T's screwed onto the ends of the spray-pipes.

U is a quadruple L-union. (See Figs. 1 and 10.) V² is a similar union. This union connects with the four crosses. (See description of Fig. 10.)

Fig. 5 represents a broken section of the furnace and rim M, also of a quarter-section of the partition forming the flue X², in conjunction with case N. This view is to represent more fully the arrangement for supporting and securing the bottom coils. A projection, *t'*, with recesses therein, is cast upon the rim M. These recesses are made to fit the different-sized pipes. A capped flange, *t*, is cast with the partition, and with recesses corresponding to *t'*. This flange acts as a binder for the bottom coils.

Figs. 6 and 7 are views of the combination quadruple flanged T and union connection. This connection is made in the manner shown, and cast in one piece. The curvature of the cylindrical portion and the varying angles of the flanges to said cylinder are for the purpose of conforming to the faces of the flanged bushings which are connected with the four crosses U¹, &c.

The reason why the angles of the face of the flanged bushings vary is because their axial line proceeds from a common center. Again, the reason why their faces are not in a curved plane or arc of a circle described from a common center is this: The pipes forming the spiral boiler A A', &c., decrease in size as they approach the center for obvious reasons. Consequently the four crosses connecting with said pipes vary correspondingly in size, while their centers are upon the arc of a circle described from the center of the coils. This being so, the plane of the face of the bushing *s*³ will be nearer the center of the circle than that of *s*², *s*¹, and *s*³. By reason of this difference the necks of the flanges on T' will, to meet the requirements, vary accordingly.

The center of the manifold T' is on the arc of a circle described from the common center, also connections U and V.

I do confine myself to the special parts described above, T' U, for these parts can be substituted by the use of regular fittings without changing the principle involved.

Fig. 8 is a sectional top-plan view of the outer case, N, the partitions Q and L, steam-generating coils A' B' C' D', hot-water coils *k k'*, and cold-water coil *l*; also, a horizontal sectional view of the upper connections, and a plan view of the corresponding lower connections, described in Figs. 4, 6, 7.

The parts T and Y are duplicates of T' and Y' in the lower connection. (See Figs. 4, 6, and 7.)

These upper connections are upon the same arcs of circles as those of the lower; but their positions are reversed, as seen in the figures. It is not absolutely necessary that their positions should be reversed, or that they should extend to the right and left, as seen in the figure, for they may be placed one directly above the other, either with or without reversed positions; but for the sake of convenience in bending the coils and securing them in position, and for making up the necessary connections in constructing a large boiler of from forty to one hundred horse-power, I prefer the arrangement as shown; but in boilers of small powers, when less amount of coils is required, the connections need not be so elaborate.

The arrangement herein shown is susceptible of a great variety of modifications, all of which will accomplish equally good and equivalent results.

X¹ is an induction-pipe, through which the water is forced into the bottom of the outer coil, *l*, thence upward through said coil, whence it makes its exit into the T E', where it divides, and is forced through the pipes H' and F' to the L-connection, whence it is turned downward, and enters the hot-water coils *k k'* at their bottom coils, thence passing upward and making its exit from the said coils through the pipes *d', G', and I'* into the quadruple connection Y and Y'. Thence it is forced into the internal pipes *a' b' c' d'*, and is sprayed out into the steam-generating coils, where it is converted into steam.

g is a blow-off pipe to the internal pipes, while *f* is the blow-off to the crosses U¹, &c.

Fig. 9 represents a quarter section of the partition L. At the base of this section the binders which cover the series of pipes which project from the bottom coils are shown. These binders are cast with the section also the supports for the pipes extending from the top coils, which are represented at P'. The binders which correspond to these supports P' will be seen in Fig. 1 at P. These are cast with the curved flanged ring O, on which the lower drum-head rests.

Fig. 10 is a view of an exterior elevation of a steam-generating apparatus. This view shows an arrangement of pipes and fittings which controls the action of the water and steam without and within the boiler.

The operating of the above-described invention is as follows: In order to commence the operation of generating steam, the water-coils should be filled with water and then a fire built in the furnace, which will soon heat the coils enough to convert said water into steam, which will be sufficient to start the pump or injector, after which water will be forced through the water-induction pipe K' J' and into the cold-water coil at *h'*. After passing through this coil it is forced into and through pipes H' and F', and then passes through pipes *y² y³* into the bottom of the hot-water coils, thence passing upward through said coils, and then out through the pipes G'

and I' into the quadruple connections Y Y'. It is then forced from the connection Y up through the series of pipes *z² z³ x² x³*, whence it turns through the L's *n¹ n² n³ n⁴* into the series of internal spray-pipes, *a' b' c' d'*, as seen in Fig. 8.

q q¹ q² q³ are bushings through which the spray-pipes project and receive their respective L's. *w¹ w² w³ w⁴* are flanges in T-connection.

The water in Y' is forced down through a series of pipes, *a' a² a³ b²*, into the T's *n v¹ r² r³*, whence it turns into the lower ends of the spray-pipes *a b c d*, as seen in Fig. 4.

o o¹ o² o³ are bushings, through which the spray-pipes project and connect with the T's. *s s¹ s² s³* are flanges belonging to connection T'. *m¹ m² m³ l³* are pipes connecting the L's with the connection U, and are used to draw and blow off the water and sediment from the internal spray-pipes. This water is drawn off through the water-pipe *g* by turning valve 4.

The drainage from connection Y is through pipe *m* and valve 2, then into Y', thence through valve 3, pipe *a'*, T *n*, pipe *m'*, into connections U, thence through pipe *g* to waste-pipe. Also, the water may pass by the way of pipe I' through valve 7, thence into pipe X¹, and then through a branch pipe. (Not shown.)

V¹ W¹ are vertical check-valves, to prevent water from being forced back into the cold-water coil. Also, check-valves should be used between the hot-water coils and the spray-pipes.

f¹ f² f³ are pipes connecting the crosses U¹, &c., (see Fig. 4,) with the connection V. This connection, which communicates with the water-coils A B C D, should always be kept full of water while steam is being generated. It can be supplied with water by an injector or other means—as, for instance, the condensation of steam within the drum—and water carried over by the action of steam from the boiler into said drum will be conducted through the pipe *h* into the quadruple connection V, thus filling the crosses U¹ and the water-coils A, &c., until the water rises in said coils to the level of the overflow *h'* in the pipe *h*, after which the surplus water will pass through the overflow-pipe into the trap.

As the steam-drum is surrounded by heat and its condensing-surface destroyed, the means herein specified for keeping the water-coils full will not be sufficient to meet the requirements, unless there should be a greater amount of water forced into the boiler than can be converted into steam. When this is done a sufficient amount of water will be carried over into the drum and return by the water-coils, as above set forth. Another means which should not be overlooked is this: Whenever the coils are supplied with a greater amount of water than the steam-generating capacity of the boiler-coils will admit of, a portion of said water, minus that which is carried into the drum, will gravitate to the water-coils, thus keeping them full to the overflow-point *h'*. Now, by a judicious management by the

operator of this boiler, these water-coils can, by either one separately or by a combination of the two means above cited, be kept full to the overflowing-point without the use of an injector.

A water-gage, although not shown in the drawings, should be connected with the overflow-pipe *h'*. This gage will serve as a means of determining the amount of water to be forced into the coils, for a greater amount than is necessary to keep the water-coils full will overflow and pass off through the trap. Consequently an amount of heat equal to that contained in the water which overflows and passes off through the trap is lost.

Furthermore, if a steam-drum is situated outside of the furnace-heat and its surface allowed to become a condensing-surface, then the condensation from said drum may be equal to the evaporation in the water-coils, whereby the water-coils will be kept full without the aid of any other means. Also, a regulator can be employed to regulate the quantity of water forced through the induction-pipe *X*¹. Therefore it will be seen that, after all parts are properly adjusted and a self-fuel-feeding attachment which I have in view be adopted, the apparatus will become automatic in its action until another supply of fuel is required.

The induction-pipe *X*¹ is provided with two branch induction-pipes, *K*¹ *L*¹. These branch pipes connect with the connections *Y* and *U*, for the purpose of showing that cold water can be injected into the internal spray-pipes without having to pass through the cold and hot water pipes *l* and *k*¹, although cold water should never be introduced into the interior set of steam-generating coils, *A*¹ *B*¹ *C*¹ *D*¹, for the reason that it is unnatural and injurious to subject a useful element to an extreme degree of heat and cold, as would be the case were cold water to be forced into a red-hot boiler.

The device for keeping water within one or more coils at the bottom of the spiral boiler, as fully shown in Fig. 1, obviates the difficulties heretofore experienced in the burning out of the bottom coils, or those which come in contact with the flame.

Now, as the coils are kept full to a certain point, as described in the foregoing part of this specification, there can be no dry heat within the coils. Consequently oxidation cannot be so rapid as if said coils were dry and filled with superheated steam.

As long as water remains in the coils moist steam will be ascending therefrom and filling the coils above, which in this instance serve the purpose of a steam-drum; but when water is sprayed through the internal pipes into the interiors thereof, they then become generators, and their interior surfaces are active in generating steam, which is allowed to pass off at either end of the coils into the quadruple connections *T* and *T'*, thence escaping up and through the stand-pipes *Q* and *Q'*, through the valves *R* and *R'*, to the central connecting-*T*,

S, as seen in Fig. 1, thence passing into the steam-pipe *XII*, thence into the steam-drum *XIII*. (See Figs. 1 and 10.)

By closing the valve *R*, the steam can be made to pass down through the coils to their lower connections and into the stand-pipe, thence to the drum; or by closing valve *R'* the steam may all be discharged through the top connections, thence through *Q*, valve *R*, and pipe *XII* into the drum.

The water can, in a similar manner, be made to pass in at either the top or bottom of the coils separately or conjointly, as circumstances may dictate, simply by opening and closing the proper valves 1, 2, and 3.

It will be observed in Figs. 1 and 4 that the water-coils are larger than their respective steam-pipes. The method of joining the larger and smaller pipes in the same coil is this: The large pipe is drawn down, while the end of the small pipe is expanded until the two diameters correspond, after which they are welded and then coiled; but before being coiled the interior steam-pipe within the water-coil is inserted, also the spray-pipe, after which the pipes are bent or coiled at the same time.

Another method which I have adopted for the water-coils is to continue the pipes *A*¹ *B*¹ *C*¹ *D*¹ to the bottom, and insert a smaller pipe to conduct the steam off, which will be sufficient to take away what steam may be generated in the lower half of the coils.

It will be observed that the steam will have to enter the ends of the inserted coils, which the unconverted water cannot enter, by reason of the overflow at *h'*; but if, by any means, water should overflow into the steam-pipe it will pass into the *T*¹ connection, thence through pipe *g* to the trap.

I have adopted a plan of heating, boiling, and converting the water to steam on an increasing temperature.

In the flue at the greatest distance from the fire I locate my first coil or coils, into which the cold water is injected, to which, in passing through said coil, a certain degree of heat is imparted, which is transmitted from this coil to another coil or coils, located within another flue, at a still greater degree of heat, when, with the transmitted heat, the water will pass from this flue with a greater number of thermal units of heat than it would were it not to receive the transmitted heat derived from the first flue. What is said of the two first flues applies to all remaining flues until the water is converted to superheated steam. I extend these flues, which I call "cold and hot water flues," until the water boils, after which the boiling water is forced into the internal pipes and sprayed out into the interior of the boiler-coils within the furnace and combustion-chamber. Now, these boiler-coils being within the highest degree of heat that the combustion of the fuel affords, converts this boiling water into steam with great rapidity. Consequently an advantage is derived by absorbing and bringing back the heat necessary

to raise water to a boiling-point. Now, it is obvious that, if this heat were not brought back, said heat would be a total loss, which amounts to about one-sixth of the fuel consumed.

It will be observed that the four steam-coils are all independent of each other, with the exception of their connections at their opposite ends on the outside of the furnace, as shown and described. Consequently the steam made within one coil cannot pass into either one of the other coils, as is now done, when the coils are made from a continuous pipe. When a coil-boiler is made in this manner it has but the area of its own pipe for the delivery of steam. Consequently the water and steam combined have a long frictional distance to flow through before reaching the outlet, while with my coils I double the area of discharge (minus the diameter of spray-pipe) on each coil. Therefore with an equal number of feet of pipe I am enabled to obtain eight times the area of discharge (minus the spray-pipes) obtained in the former case. Furthermore, the steam flows but one-eighth of the distance in leaving the coils. In consequence of this free discharge the pressure in the coils and drum will be nearly equal when a motor is in operation, while in the other case there must be a difference, and in consequence of this difference the back-pressure upon the injector or pump must be greater than in the latter case.

It is evident that the steam-generating capacity is greater in the latter case than in the former, and as the boiling water is introduced into the interior of the coils and sprayed out in contact with the hot generating-surfaces, those hot surfaces will be preserved from the injurious action of the intense heat within the combustion-chamber. Therefore there will be no unevenness in temperature or pressure, provided the degree of heat is uniform.

If it ever should become necessary to generate superheated steam, the steam can be made to flow through one or more of the coils by a modification of the outside connections.

I prefer to make the two hot-water coils separate and join them on the outside, for water will flow with less friction and with one-half the velocity (the diameters being equal) than if it were in one continuous length; also, the back-pressure is not so great, or will be no greater, than in the drum; consequently the pump or injector will be constant in its action.

I am aware that coiled pipe or spiral boilers have heretofore been and are now in use for boiling water and for its conversion into steam within the limits of one or two of its top coils, while the remainder of the coils are kept full of water by circulation. Now, a boiler of this design, construction, and principle I lay no claim to.

Therefore the principles, construction, and operation of the two devices are very dissimilar. If I flooded my boiler-coils, the results produced would be similar; but as I do not flood them, (in consequence of special means adapted to obviate that difficulty,) their entire interior

surfaces become a converter; consequently superior results are obtained.

It will be observed that the water can be drained from the bottom of all of the coils, also from the drum and connecting-pipes, through the trap.

Various modifications of the construction of this boiler can be made without departing from the principles involved, and as herein set forth.

This primary coil or coils, which are provided with spray-pipes, will receive the incoming boiling water from the extended flues, whereby a sufficient degree of heat is imparted and becomes absorbed in its conversion, there fore latent, after which it will pass to the coils within the greater heat, where it will receive the heat which determines its pressure.

What I claim as new, and desire to secure by Letters Patent, is—

1. Two or more steam-generating coils, A' B' C' D', connected at their bottom ends, in combination with steam-fittings T' and steam-conducting pipe leading therefrom to a drum or motor, for the purpose set forth.

2. Two or more steam-generating coils, A' B' C' D', connected at their top ends with steam-fittings T and conducting steam-pipes leading therefrom to steam-drum or motor, in combination with the bottom ends of said steam-generating coils and their connections leading to said drum, for the purpose set forth.

3. Two or more steam-generating coils, A' B' C' D', connected at their top ends with and in combination with steam-fittings T and $w^1 w^2 w^3 w^4$ and steam-pipes leading therefrom to a steam-drum or motor, for the purpose set forth.

4. In combination with the bottom ends of two or more steam-generating coils, A' B' C' D', and their steam-connections T' and $s s^1 s^2 s^3$, and steam-pipes leading therefrom to a drum or motor, the internal spray-pipes $a b c d$, for conducting water into said bottom ends of said steam-generating coils and spraying it out therein, as described, and for the purpose specified.

5. In combination with the top ends of two or more steam-generating coils, A' B' C' D', and their steam-connections T and $w^1 w^2 w^3 w^4$ and steam-pipes leading therefrom to a drum or motor, the internal spray-pipes $a^1 b^1 c^1 d^1$, for conducting water into said top ends of said steam-generating coils and spraying it out therein, as described, and for the purpose specified.

6. The arrangement of the top ends of two or more steam-generating coils, A' B' C' D', and their steam-connections T and $w^1 w^2 w^3 w^4$ and steam-pipes leading therefrom to a drum or motor, and internal spray-pipes $a^1 b^1 c^1 d^1$, for conducting water into said top ends of said steam-generating coils and spraying it out within said coils, with and in combination with the bottom ends of two or more steam-generating coils, A' B' C' D', and their steam-connection T' and $s s^1 s^2 s^3$, and steam-pipes

leading therefrom to a drum or motor, and the internal spray-pipes $a b c d$, for conducting water into said bottom ends of said steam-generating coils and spraying it out within said coils.

7. The manifold T' , provided with apertures and flanges, in combination with the fittings $o o^1 o^2 o^3$ and $s s^1 s^2 s^3$, and the steam-pipes $A' B' C' D'$ and spray-pipes $a b c d$, and steam-education pipe Q , as described, and for the purpose set forth.

8. The manifold water-reservoir Y and induction-pipe I' or L' leading from and connecting thereto, education-pipes $z^3 z^2 z^3 x^2$, connected with and leading therefrom, in combination with the internal spray-pipes $a' b' c' d'$ and top ends of the steam-coils $A' B' C' D'$, as described, and for the purpose set forth.

9. The manifold water-reservoir Y' and the induction-pipe G' , leading thereto, and education-pipes $a^1 a^2 a^3 l^2$, connected with and leading therefrom, in combination with the internal spray-pipes $a b c d$ and bottom ends of the steam-coils $A' B' C' D'$, as described, and for the purposes specified.

10. In combination with the reservoir Y and induction-pipe I' , the drainage-pipe m and valve 2, or pipe L' and valve 7, for the purpose specified.

11. In combination with the quadruple blow-off connection U , blow-off pipe g , valve 4, and pipes $n v^1 v^2 v^3$, the internal spray-pipes $a b c d$, and the bottom ends of the steam-coils $A' B' C' D'$, for the purpose specified.

12. In combination with the quadruple blow-off connection U , the induction-pipe K' , valve 8, and connecting-pipes $m^1 m^2 m^3 l^3$, and the internal spray-pipes $a b c d$, for the purpose specified.

13. The quadruple connection Y , induction-pipe I' , education-pipes $z^3 z^2 z^3 x^2$, and the internal spray-pipes $a' b' c' d'$, leading into the top of the steam-generating coils $A' B' C' D'$, in combination with quadruple connection Y' , the induction-pipe G' , leading thereto, education-pipes $a^1 a^2 a^3 l^2$, leading therefrom, and connected with the internal spray-pipes leading into the bottom ends of the steam-generating coils $A' B' C' D'$, as described, and for the purpose set forth.

14. The water-connections Y , induction-pipe I' , education-pipes $z^3 z^2 z^3 x^2$, internal spray-pipes $a' b' c' d'$, steam-pipe Q , and valve R , closed, in combination with the bottom ends of the steam-generating coils $A' B' C' D'$, steam-connections T , pipe Q , valve R' , open, and steam-pipe leading to a drum or motor, for the purpose specified.

15. The water-connection Y' and U , education-pipes $a^1 a^2 a^3 l^2$, or $m^1 m^2 m^3 l^3$, internal spray-pipes $a b c d$, pipe Q' , and valve R' , closed, in combination with the top ends of the steam-coils $A' B' C' D'$, steam-connections T , pipe Q , and valve R , open, and steam leading to a drum or motor, for the purpose specified.

16. One or more steam-generating coils of

pipe, $A' B' C' D'$, provided at their bottom ends with an exterior or interior coiled pipe, $A B C D$, extending upward one or more turns or coils, with an intermediate water-space between said steam-pipe and said exterior or interior pipe, for the purpose specified.

17. The water-coils $A B C D$, in combination with the crosses $U^1 U^2 U^3 U^4$, and blow-off pipes $f f^1 f^2 f^3$, and quadruple connection V , and waste-pipe, for the purpose specified.

18. The steam-generating coils $A' B' C' D'$ and the water-coils $A B C D$, in combination with the reservoir V or X , overflow h' , or its equivalent, and the trap VII , for the purpose specified.

19. The steam-generating coils $A' B' C' D'$, and water-coils $A B C D$, reservoir X , and overflow h' , in combination with an equalizing-pressure steam-pipe, h , and steam-drum $XIII$, for the purpose specified.

20. In combination with the steam-generating coils $A' B' C' D'$ and water-coils $A B C D$ and blow-off pipe f and valve 6, the internal spray-pipes $a b c d$ and their water-connections.

21. In combination with the steam-generating coils $A' B' C' D'$, water-coils $A B C D$, and internal spray-pipe $a b c d$, a trap for conducting off surplus water from said steam-generating coils and the overflow from said water-coils into said steam-coils, for the purpose specified.

22. In combination with steam-generating coils $A' B' C' D'$, provided with water-coils $A B C D$ at their bottom ends and steam-outlet through said water-coils, arranged within the furnace and combustion-chamber, as and for the purpose specified.

23. A furnace provided with a rim, M , with annular partitions Q and L thereon, provided with flue-openings J therein, deflector O , and case N , in combination with cold-water pipes or pipe l , hot-water pipe or pipes $k k'$ within flues formed by said partitions.

24. Two or more separate heating coil or coils within one, two, or more flue-spaces, said separate coils in each said flue-space being connected with said separate coil or coils within the adjacent flues in such manner that water will flow in a number of streams equal to the number of separate pipes within each said flue, for the purpose specified, and in combination with steam-generating coil or coils within a flue or chamber, where the conversion of water to steam is effected.

25. A tubular steam-drum, the lower tube-sheet of which forms a continuation of the combustion-chamber, the upper tube-sheet of said drum being provided with a damper, p , in combination with a furnace containing steam-generating-coils, said coils discharging steam into said drum through pipes connecting therewith, substantially as described.

26. The steam-drum head Z' , in combination with the annular deflector O , partition L , flues X and V , and combustion-chamber IV , for the purpose as shown.

27. A section of partition, L , provided with

a support, P', and binder t, in combination with binder P in deflector O and support t' in rim M, and steam-coils A' B' C' D'.

28. In combination with water-coil l and coils k k', located within extended flues X² V², steam-generating coils, as shown, with internal spray-pipes therein, said steam-generating coils being located within a furnace or combustion-chamber of a steam-generating apparatus, in the manner set forth.

29. Induction-pipe J', leading from an in-

jector or pump to cold-water coil l, eduction E', leading from said coil, branch pipe H' F', leading to hot-water coils k k', eduction-pipe I' G', leading from said coils to the water-connection, communicating, and in combination with the internal spray-pipes and steam-generating coils, for the purpose specified.

WM. FRANK BROWNE.

Witnesses:

HENRY L. DYER,

MARK B. DAVIS.

Correction in Letters Patent No. 208,790.

This is to certify that the annexed Letters Patent No. 208,790, granted October 8, 1878, for Improvement in Steam-Generators, to W. F. Browne, has been corrected for the purpose of remedying a clerical error by inserting upon page 3, column 2, line 55 of the printed specification accompanying and forming part of said Letters Patent, and immediately preceding the word "confine" upon said line, the word "not," so that the sentence shall read, "I do *not* confine myself," etc., to accord with the Office records.

October 26, 1878.