

H. BURGESS.

Covering for Steam-Pipes, Generators, &c.

No. 208,791.

Patented Oct. 8, 1878.

FIG. 1.

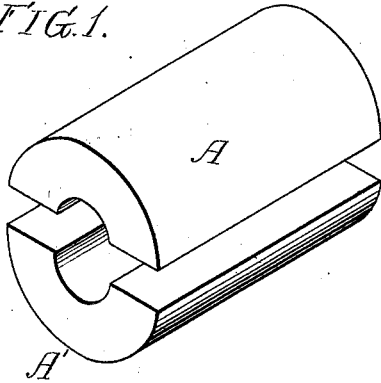

FIG. 2.

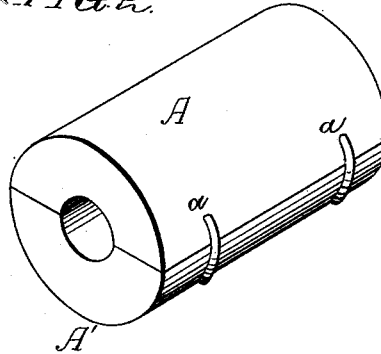

FIG. 3.

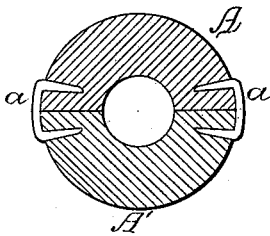
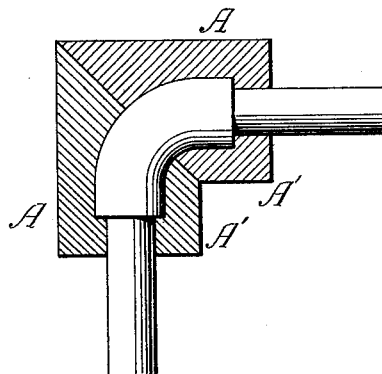

FIG. 4.



Witnesses,

Henry Howson Jr.  
Harry Smith

Inventor,

Hugh Burgess  
By his Attorneys  
Howson & Co.

# UNITED STATES PATENT OFFICE.

HUGH BURGESS, OF ROYER'S FORD, PENNSYLVANIA.

IMPROVEMENT IN COVERINGS FOR STEAM PIPES, GENERATORS, &c.

Specification forming part of Letters Patent No. **208,791**, dated October 8, 1878; application filed August 5, 1878.

*To all whom it may concern:*

Be it known that I, HUGH BURGESS, of Royer's Ford, Montgomery county, Pennsylvania, have invented a new and useful Improvement in Coverings for Steam Pipes, Generators, &c., of which the following is a specification:

My invention consists of segmental or semi-tubular blocks of paper-pulp or of pulp combined with other material in combination with staples, by which the said blocks may be secured to pipes and other objects which it is desirable to clothe with non-conducting material.

In the accompanying drawing, Figure 1 represents, in perspective, two sections of pipe-covering; Fig. 2, the same, showing two united sections; Fig. 3, a transverse section of Fig. 2, showing the mode of connecting the sections together, and Fig. 4 an illustration of the mode of applying the sections to the bend or elbow of a pipe.

In carrying out my invention I prefer to use paper-pulp, or a composition of which pulp forms a part. It may consist, for instance, of one part of paper-pulp and three parts of common sawdust intimately mixed together and with water to such a consistency that it can be readily formed into the segmental or semi-tubular blocks or sections A A'. (Shown in Figs. 1 and 2.)

While these blocks or sections may be formed in molds or otherwise shaped, I prefer to make

them by the apparatus for which I have made a separate application for a patent.

A small quantity of alum and lime may be mixed with the composition to render it incombustible or nearly so.

The semi-tubular or segmental blocks are fitted to a pipe and secured by staples *a a*, as shown in Figs. 2 and 3, and where there is a bend or elbow in the pipe the sections may be beveled by cutting them with a saw—for instance, so as to fit together in the manner shown in Fig. 4, the interior of the sections being enlarged for receiving the elbow or other joint.

The sections are made in comparatively short lengths for convenience of transportation and application to a pipe, one pair of sections being fitted against another pair until a pipe is clothed throughout its entire length with as many sections as may be demanded.

I claim as my invention—

The combination of the within-described segmental blocks, consisting of paper-pulp or like penetrable material, with the staples by which they are secured, as set forth.

In testimony whereof I have signed my name to this specification in the presence of two subscribing witnesses.

HUGH BURGESS.

Witnesses:

HENRY HOWSON, Jr.,  
HARRY SMITH.