

J. H. LUTHER.

Clamp for Polish Rods of Oil and Other Wells.

No. 208,832.

Patented Oct. 8, 1878.

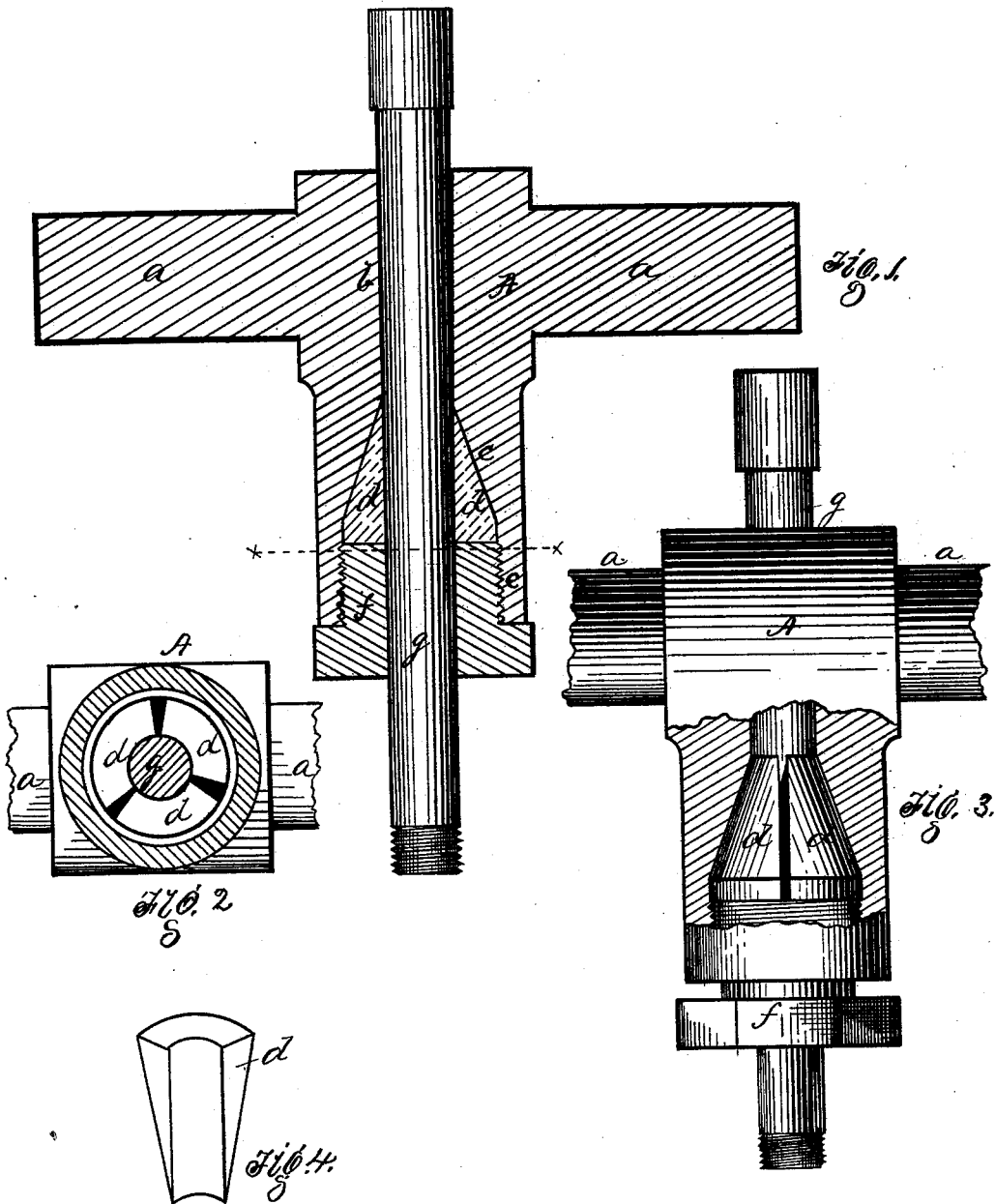

Witnesses  
John K. Smith  
R. H. Whittlesy

Inventor  
James H. Luther  
by Bakewell & Kern  
attys

# UNITED STATES PATENT OFFICE.

JAMES H. LUTHER, OF KARNS CITY, PENNSYLVANIA.

IMPROVEMENT IN CLAMPS FOR POLISH-RODS OF OIL AND OTHER WELLS.

Specification forming part of Letters Patent No. **208,832**, dated October 8, 1878; application filed September 23, 1878.

*To all whom it may concern:*

Be it known that I, JAMES H. LUTHER, of Karns City, in the county of Butler and State of Pennsylvania, have invented a new and useful Improvement in Clamps for Polish-Rods; and I do hereby declare the following to be a full, clear, and exact description thereof, reference being had to the accompanying drawing, forming part of this specification, in which—

Figure 1 is a central vertical section of devices embodying my invention. Fig. 2 is a transverse section on the line *x x*, Fig. 1. Figs. 3 and 4 are detail views of the devices.

Like letters refer to like parts wherever they occur.

My invention relates to the construction of clamps for polish-rods, employed in operating oil and similar artesian wells; and consists, mainly, in the combination, with a cylinder, of a series of wedges and a follower adapted to gripe and hold the rod at any desired point, whereby simplicity of devices with easy and effective adjustment is obtained.

In pumping oil and other deep-bored or artesian wells a connected series of sucker-rods is commonly used to operate the valves, and said sucker-rods are connected to the working-beam by a piston, or what is termed a "polish-rod," which works through a packing, and is connected to the beam by a clamp.

As experiment is necessary to determine the best position for the working-valves and the length of stroke, &c., and as the rods have to be withdrawn, replaced, and renewed from time to time, it is always desirable that the clamp or polish-rod adjuster should be both simple and effective. Heretofore, so far as I am aware, these clamps have been generally made in several sections, held together and caused to bite on the rod by bolts, &c., which rendered it more or less difficult to release the rod and reclamp it with anything like rapidity or nicety of adjustment. In some instances a single hollow casting, through which the polish-rod passed, has been employed, and the clamping and adjustment of the rod effected by a set-screw, which passed through the casting and bore against the rod; but this latter device was liable to deface the polish-rod, and invariably pushed it off the center, causing it to wear, cramp in the packing, &c.

The object of the present invention is, therefore, to obtain a cheap, simple, and effective clamp or polish-rod adjuster, not liable to the objections specified.

I will now proceed to describe my invention, so that others skilled in the art to which it appertains may apply the same.

In the drawing, *A* indicates the clamp, having the hollow body for the passage of the polish-rod, and journals *a* for connection with the walking-beam. The hollow body is preferably of cylindrical form, narrow above, as at *b*, where the rod passes out, and widened out below usually in form of a hollow cone, as shown at *c*, where the wedges are situated.

*d* indicates the wedges, concave upon one side, or otherwise suitably shaped, to clamp or apply themselves to the polish-rod, and convex upon the opposite surface, to fit the cone-shaped cavity *c*.

The lower end of the cylinder, below *c*, is tapped or threaded, as at *e*, to receive a screw-tap or follower, *f*, by means of which the wedges *d* may be forced up, so as to bring them closer together and cause them to clamp the polish-rod. *g* indicates the polish-rod, of any approved form.

The devices when in use occupy the position and relations shown in Fig. 1, and the rod may be released, adjusted, and clamped as follows: Supposing the rod to be clamped, and it is desirable to release it for adjustment or from any cause, the follower *f* is turned, to slightly withdraw the same, which permits the wedges *d* to drop down, or, in case they do not, a slight jar on the clamp or rod will cause them to fall into the wider part of cavity *c*, thus releasing the polish-rod *g*, which can then be raised or lowered the desired distance, or the clamp itself can be raised or lowered, after which the follower *f* is screwed in, thus forcing the wedges *d* into a narrower portion of cavity *c*, which drives the wedges together, causing them to clamp the polish-rod.

Should the polish-rod work loose from any cause, it can be immediately and readily secured, without loss of time or adjustment, by simply turning the follower *f*.

The advantages of my invention are simplicity and effectiveness, the readiness and quickness with which the polish-rod can be

adjusted and centered, and the secure manner in which the rod is held without injuring or defacing it.

For the purposes of this specification a cylinder with cone-shaped cavity and a series of wedges forming a hollow cone arranged therein have been chosen as illustrating the invention; but it will be evident to the skillful mechanic that various equivalent devices may be substituted and analogous results obtained. Therefore I do not wish or expect to be limited to the exact devices shown; but,

Having thus set forth the principle and advantages of my invention, what I claim, and desire to secure by Letters Patent, is—

A clamp for polish-rods and like purposes provided with the body having a hollow tapered cavity, a series of wedges arranged therein, and a follower to act on the wedges, the whole combined substantially in the manner and for the purpose specified.

In testimony whereof I, the said JAMES H. LUTHER, have hereunto set my hand.

JAMES H. LUTHER.

Witnesses:

J. M. HURTY,

GEORGE W. GIFFORD.