

D. E. TEAL.
Folding and Tilting Chair.

2 Sheets—Sheet 1.

No. 208,864.

Patented Oct. 8, 1878.

Fig. 1.

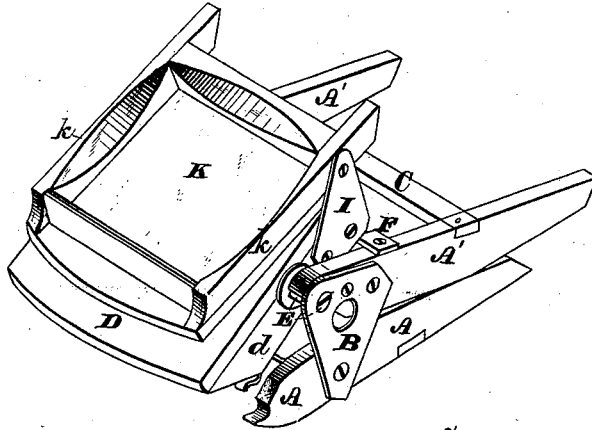
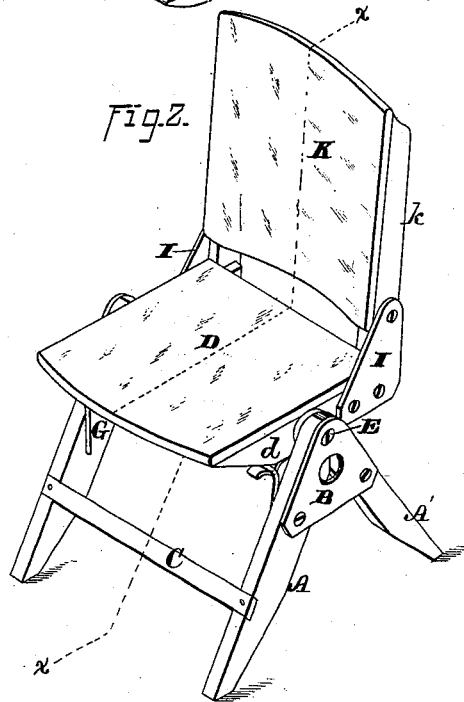

Fig. 2.



WITNESSES

*Jas. C. Hutchinson.
 Henry G. Hazard.*

INVENTOR

*David E. Teal, by
 Prindle & Co. his Attys.*

D. E. TEAL.
Folding and Tilting Chair.

No. 208,864.

Patented Oct. 8, 1878.

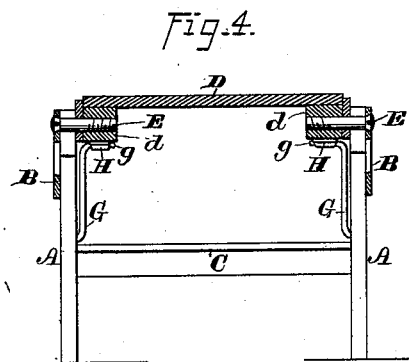
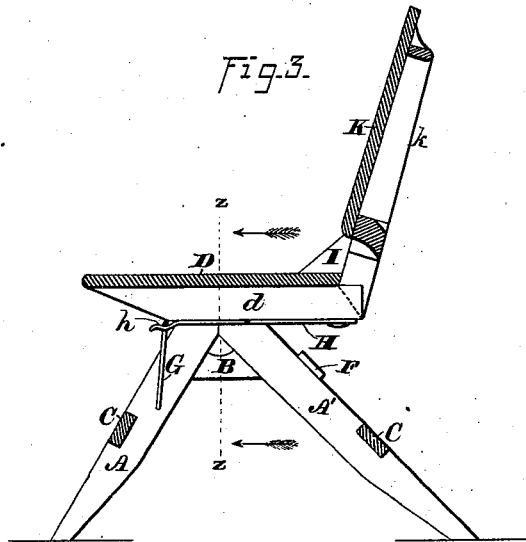

WITNESSES

Geo. E. Hutchinson
Henry S. Hazard

INVENTOR

Daniel E. Teal, by
Quindley & Co. his attys

UNITED STATES PATENT OFFICE.

DANIEL E. TEAL, OF ONEIDA, NEW YORK.

IMPROVEMENT IN FOLDING AND TILTING CHAIRS.

Specification forming part of Letters Patent No. **208,864**, dated October 8, 1878; application filed April 27, 1878.

To all whom it may concern:

Be it known that I, DANIEL E. TEAL, of Oneida, Madison County, State of New York, have invented certain new and useful Improvements in Chairs; and do hereby declare that the following is a full, clear, and exact description thereof, reference being had to the accompanying drawings, making a part of this specification, in which—

Figure 1 is a perspective view of my chair folded together for storage. Fig. 2 is a like view of the same opened and arranged for use. Fig. 3 is a vertical section upon line *xx* of Fig. 2, and Fig. 4 is a like view upon lines *zz* of Fig. 3.

Letters of like name and kind refer to like parts in each of the figures.

The design of my invention is to combine in one chair the essential features of a tilting and a folding chair; and to this end it consists, principally, in a chair in which are combined the following elements, to wit: a jointed stool capable of being folded together, a seat and back hinged or pivoted together and capable of being folded, and a pivotal spring-connection between said seat and stool, whereby the latter is permitted to rock upon said stool, substantially as and for the purpose hereinafter specified.

It consists, further, in the peculiar construction of the stool, substantially as and for the purpose hereinafter shown.

It consists, further, in the construction of the seat and back, and their combination with each other, substantially as and for the purpose hereinafter set forth.

It consists, further, in the means employed for connecting the seat to or with the stool, and for limiting the oscillation of said seat, substantially as and for the purpose hereinafter shown and described.

It consists, finally, in the chair as a whole, its several parts being combined to operate in the manner and for the purpose substantially as hereinafter specified.

In the annexed drawings, A and A' represent two legs, which have the general form shown in Fig. 2, and near their upper ends are pivoted to or upon the lower corners of a triangular metal plate, B. The upper ends of the legs A and A' are formed upon such lines

as to cause them to meet when the lower ends are spread, as shown in Figs. 2 and 3, by which construction said legs become self-supporting in such position, and are capable of sustaining such weight as may be placed upon their upper ends. The legs A and A', pivoted together as described, are connected with a second similar pair of legs by means of two cross-bars or rungs, C, which extend horizontally between the front and rear pairs of legs, at some point between their upper and lower ends. Pivoted to the upper corners of the plates B, between the upper ends of the legs A and A', is a seat, D, which is stiffened and strengthened at each side by means of a rail, *d*, that is secured upon and extends along its lower side. The pivotal bearings E are supported within said plates B independent of said legs. The seat D is intended to have an oscillating or tilting motion, and it is prevented from turning rearward beyond a certain point by two stops, F, one of which is attached to each rear leg, A', and engages with the lower side, near the rear end, of each rail *d*. The forward limit of motion of the seat is determined by two stops, G, which are constructed from wire in the form shown in Fig. 4, and have their lower ends pivoted within the inner face of each front leg, A, and their upper ends in position to receive the front portion of the bars *d*. The stops G are held in place, and the seat D is caused to maintain, with a yielding pressure, its normal position, by means of two springs, H, one of which is attached at one end to or upon the lower side, at the rear end of each rail *d*, and from thence extends forward beneath the horizontal arm *g* of said stop G, said spring at such point being provided with a recess, *h*, that corresponds to and receives said arm *g*.

When the seat D is free to assume its normal position, the springs H hold its forward portion down upon the stops G; but said seat may be easily tilted rearward until arrested by the stops F, the movement being similar to that of ordinary tilting-chairs.

Secured to or upon the outer face of each rail *d*, at its rear end, is a metal plate, I, which is similar in shape to the plate B, and between the same is pivoted a back, K, as shown. The lower end of each side bar, *k*, of the back K

is cut away at an angle of about forty-five degrees from a vertical line, and the whole or a part of the rear end of each seat-rail *d* is formed at a relatively opposite angle, so that when said back is turned upward to the position shown in Figs. 2 and 3, said ends meet and prevent further rearward movement of said back.

When the chair is not in use it may be folded together by disconnecting the stops *G* from the springs *H* and swinging their upper ends rearward, then folding the back *K* down upon the seat *D*, and swinging the latter downward until its front edge has passed in rear of the front rung, *C*, and then folding the legs together.

The chair thus constructed is especially useful in dining-rooms, where, when not in use, the back may be folded down and said chair moved under the table.

Having thus fully set forth the nature and merits of my invention, what I claim as new is—

1. A chair in which are combined the following-named elements, to wit: a jointed stool capable of being folded together, a seat and back hinged or pivoted together and capable of being folded, and a pivotal spring-connection between said seat and stool, whereby the latter is permitted to rock upon the former, substantially as and for the purpose specified.

2. The hereinbefore-described stool, in which the legs *A* and *A'*, having angular abutting upper ends, are connected together by means of the pivotal plates *B*, in the manner and for the purpose substantially as shown.

3. The seat *D*, having the rails *d*, with angular rear ends, the back *K*, provided with rails *k*, which have angular lower ends, and the pivotal plates *I*, used for connecting said parts together, all combined substantially as and for the purpose set forth.

4. In combination with the stool described and with the seat *D*, the pivotal bearings *E*, connecting said seat with the plates *B*, the stops *F* and *G*, and the springs *H*, substantially as and for the purpose shown and described.

5. The hereinbefore-described chair, in which the legs *A* and *A'*, pivotal plates *B*, rungs *C*, seat *D* *d*, pivotal bearings *E*, stops *F* and *G* *g*, springs *H*, pivotal plates *I*, and back *K* *k* are combined to operate in the manner and for the purpose substantially as specified.

In testimony whereof I have hereunto set my hand this 23d day of April, A. D. 1878.

DANIEL E. TEAL.

Witnesses:

B. F. BURLESON,
JAMES B. AVERY.