

F. Z. NICOLIER.
Key for Musical String Instruments.

No. 208,985.

Patented Oct. 15, 1878.

Fig: 1.

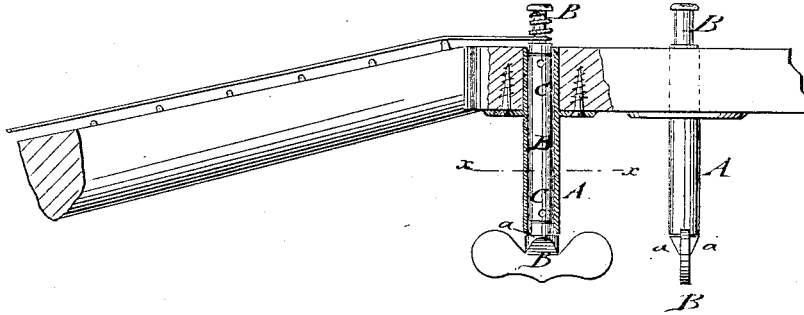

Fig: 2.

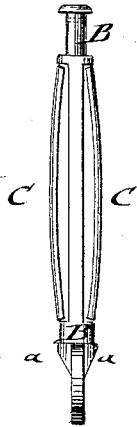
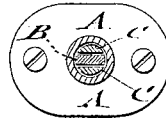

Fig: 3.



WITNESSES:

Chas. Nida
C. Sedgwick

INVENTOR:

F. Z. Nicolier
BY *Munn & Co*

ATTORNEYS.

UNITED STATES PATENT OFFICE.

FERDINAND Z. NICOLIER, OF NEW YORK, N. Y.

IMPROVEMENT IN KEYS FOR MUSICAL STRING-INSTRUMENTS.

Specification forming part of Letters Patent No. **208,985**, dated October 15, 1878; application filed April 9, 1878.

To all whom it may concern:

Be it known that I, FERDINAND Z. NICOLIER, of the city, county, and State of New York, have invented a new and Improved Key for Musical String-Instruments, of which the following is a specification:

In the accompanying drawing, Figure 1 represents a vertical central section of my improved key for string-instruments, shown as applied to the finger-board of a guitar. Fig. 2 is a side view of the key-spindle and springs detached; and Fig. 3, a horizontal section of the key on line *xx*, Fig. 1.

Similar letters of reference indicate corresponding parts.

This invention has reference to an improved key for musical string-instruments, which facilitates the tuning of the strings and retains them in positive manner at any desired tension; and the invention consists of a key for stringed musical instruments made of an inclosing-sleeve, secured permanently to the finger-board, and of a recessed key-spindle, with strong steel springs placed sidewise of the spindle, so as to bear on the inner surface of the sleeve and produce the retention of the key in fixed position.

Referring to the drawing, A represents the cylindrical sleeve of my improved key for stringed musical instruments of all kinds, and B the spindle of the key, which passes through the sleeve, and is provided at the upper end with the usual string-hole and shoulders for winding up the string at that end, and at the lower part with finger-rests for adjusting the

key. That part of the key-spindle inside of the sleeve is recessed throughout its entire length at opposite sides, and provided with strong steel band-springs C, which are placed into the recesses and rest against the end seats or shoulders of the same, as shown in Fig. 2. The spindle and springs are inserted jointly into the sleeve B until the sleeve forms contact with the projections *a* near the finger-rests of the key. In this position the springs bear with considerable pressure on the inner surface of the sleeve, and retain thereby the key, by their friction therewith, at any desired degree of tension, the friction-springs holding the key positively in position against the strain exerted thereon by the string. The strings are thereby held perfectly in tune, as there is no possibility of the giving of the keys, which are, furthermore, easily adjusted, and of cheap, simple, and durable construction. When the friction-springs are worn out they may be replaced by withdrawing the spindle, so that the key works them with the same reliability as before.

Having thus fully described my invention, I claim as new and desire to secure by Letters Patent—

A key for musical string-instruments, consisting of a fixed cylindrical sleeve and of a recessed spindle with interior friction-springs, substantially as and for the purpose set forth.

FERDINAND Z. NICOLIER.

Witnesses:

PAUL GOEPEL,
PIERRE BOISSET.