

A. R. SPROUT.
Machine for Dipping Matches.

No. 208,996.

Patented Oct. 15, 1878.

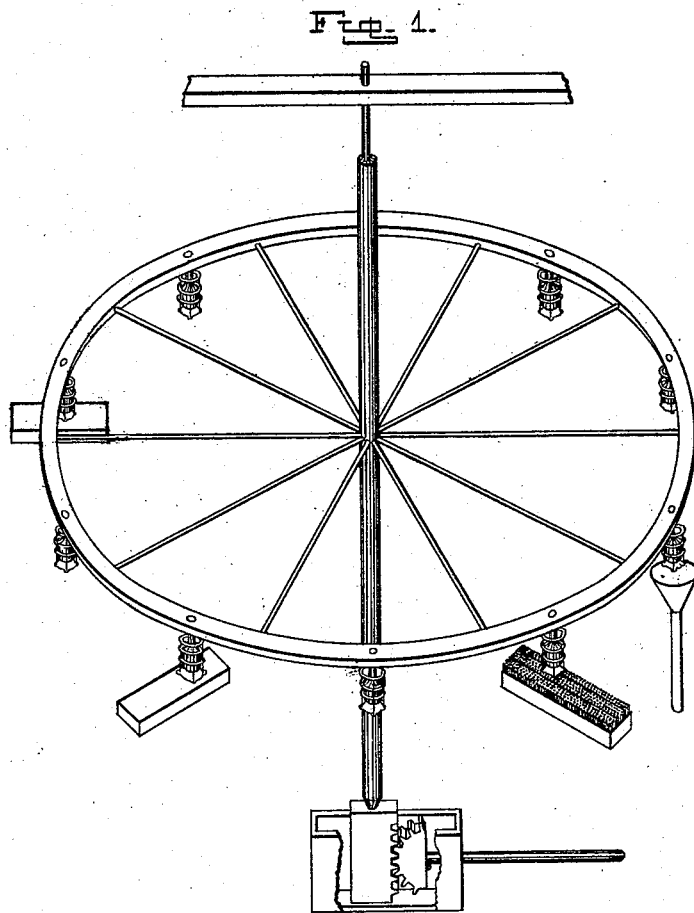

Witnesses.

J. W. Garner
H. D. James

Inventor:
A. R. Sprout,
per
J. A. Lehmann,
atty.

A. R. SPROUT.
Machine for Dipping Matches.
No. 208,996. Patented Oct. 15, 1878.

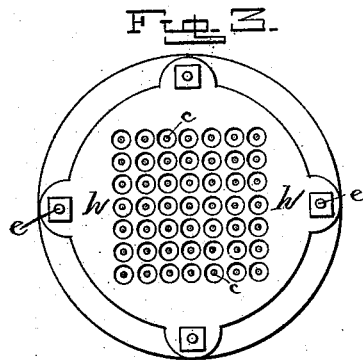
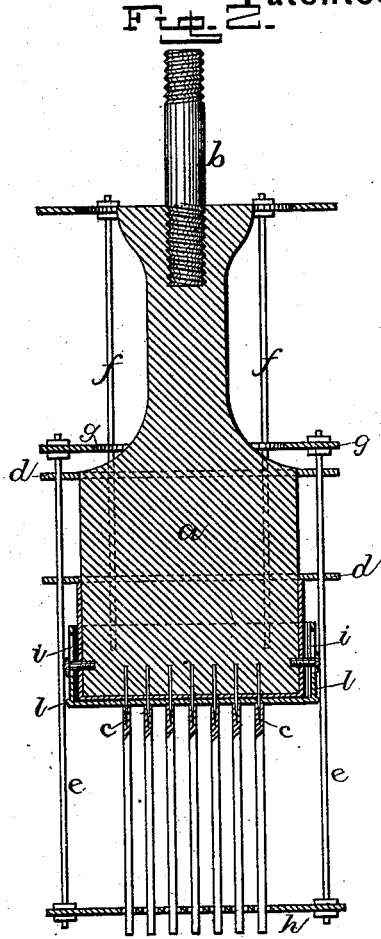

Witnesses.

J. W. Garner
M. S. D. Haines

Inventor
A. R. Sprout
per
J. A. Lehmann
att'y

UNITED STATES PATENT OFFICE.

A. RENSSELAER SPROUT, OF PICTURE ROCKS, PENNSYLVANIA.

IMPROVEMENT IN MACHINES FOR DIPPING MATCHES.

Specification forming part of Letters Patent No. 208,996, dated October 15, 1878; application filed September 21, 1878.

To all whom it may concern:

Be it known that I, A. RENSSELAER SPROUT, of Picture Rocks, in the county of Lycoming and State of Pennsylvania, have invented certain new and useful Improvements in Match-Dipping Machines; and I do hereby declare the following to be a full, clear, and exact description of the invention, such as will enable others skilled in the art to which it pertains to make and use it, reference being had to the accompanying drawings, which form part of this specification.

My invention relates to an improvement in machines for dipping matches; and it consists in a block having a suitable number of needles projecting from its end to stick into and hold the matches while being dipped, a movable perforated cap to clear out the loose unstuck matches and to hold the stuck matches steady and equidistant while being dipped, and a second perforated movable cap, which fits snugly over the end of the block and the needles, for the purpose of pushing the matches off after they have been dipped, all of which will be more fully described hereinafter.

The accompanying drawings represent my invention.

Figure 1 is a perspective of a machine embodying my invention. Fig. 2 is a vertical section of a block to which the needles are secured for picking up and holding the matches while being dipped, and Fig. 3 is an inverted view of the same.

a represents a suitable block of any desired material, size, or shape, and which is provided at its upper and smaller end with the screw-shank *b* for securing it to a horizontal wheel. Projecting from the lower end of this block are a suitable number of needles, *c*, which are arranged in any desired relation to each other, for the purpose of sticking into the ends of the sticks or splints and holding them while being dipped. These needles are secured in place by a metal cap, which is perforated, so as to allow the needles to pass through, and which fits snugly over the lower end of the block or by any other suitable means.

Secured around the block are two guides, *d*, through which pass the guide-rods *e* and *f*. The upper ends of the rods *e* are fastened to a ring, *g*, while their lower ends are fastened to

a flat perforated movable disk, *h*, through which is made a hole for each needle. As the rods *e* slide back and forth through the guides the disk can be moved up in close contact with the lower end of the block, so that all of the needles will project through it, or it can be moved as far from the end as the rods will permit. Just before the needles are pressed down upon the ends of the sticks this disk is drawn up against the end of the block, and after the needles have been forced into the sticks the disk is forced outward, so as to displace all the unstuck sticks and to hold those that have been stuck steady while being dipped. As the rods *e* are of such a length as to correspond to the length of matches, the disk will come just above the lower ends of the sticks and hold them equidistant apart, and thus prevent the ends from sticking together after having been dipped.

To the lower ends of the rods *f* is fastened the cap *l*, which fits over the lower end of the block, and which has the length of its movement controlled by the slots *i*. This cap also has a hole made through it for each needle; but the holes are much smaller than those in the disk, so that whenever desired the sticks can be instantly loosened from the needles.

The wheel, to which any desired number of the above-described machines are secured, is made vertically adjustable, so that the ends of the machines may be forced downward upon the sticks placed in a box under the rim of the wheel, then the wheel raised upward high enough to carry the sticks out of the box and revolved partially around. When the sticks are brought over the box containing sulphur the wheel is lowered far enough by the mechanism connected to its shaft to dip the ends of the sticks, and then the wheel is again raised, turned far enough around to carry the dipped sticks over the phosphorus, when the wheel is again lowered, so as to dip their ends in it. The wheel is then raised, turned around until the now perfect matches reach a funnel, when the perforated cap *l* is moved so as to push the matches off the needles, when the matches fall into the funnel. All of the movements in connection with the wheel may be performed by hand or by any suitable mechanism connected therewith that will keep up

a constant automatic action, both so far as the action of the dipping is concerned and the picking up and discharging of the matches.

Having thus described my invention, I claim—

1. In a mechanism for dipping matches, a block provided with needles for picking up and holding the sticks, substantially as shown.

2. The combination of a block provided with needles for picking up and holding the sticks with the perforated disk *h*, substantially as described.

3. The combination of the block provided with needles, a disk to hold the sticks separate while being dipped, and a disk or plate to push the matches from the needles, substantially as set forth.

4. In a match-dipping mechanism, a perforated disk, *h*, movable back and forth in relation to the block, substantially as specified.

5. The block provided with metallic points, in combination with a perforated plate, for detaching the matches from the points, substantially as shown.

In testimony that I claim the foregoing I have hereunto set my hand this 18th day of September, 1878.

A. R. SPROUT.

Witnesses:

A. J. DIETRICK,
W. J. LIPPINCOTT.