

A. E. WHITNEY.  
Leather-Splitting Machine.  
No. 209,001. Patented Oct. 15, 1878.

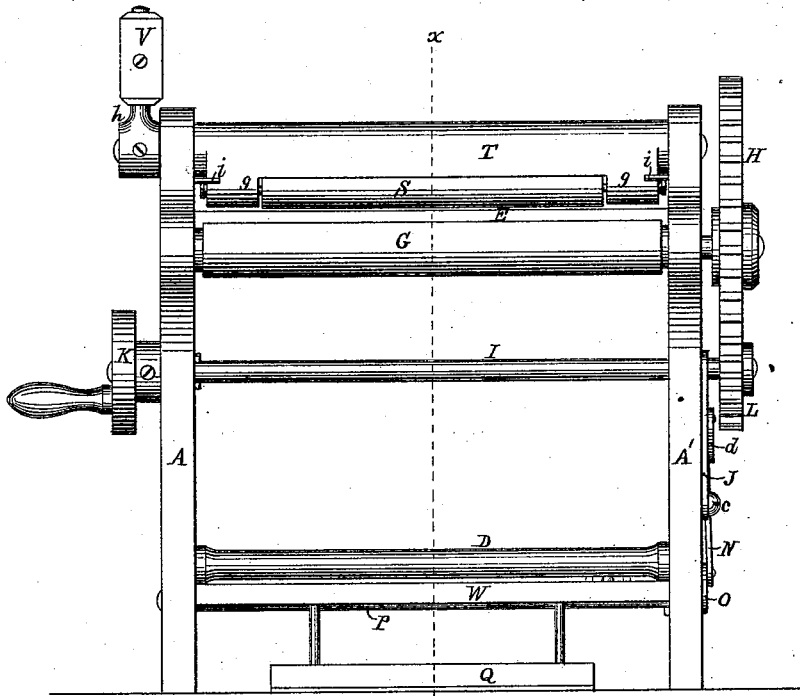

Fig. 2.

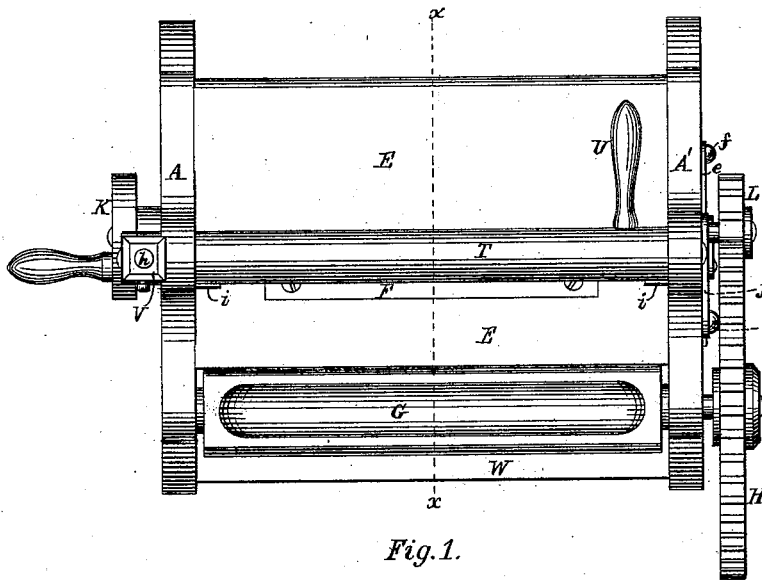

Fig. 1.

Witnesses:

*E. A. Kemmenway*  
*A. E. Whitney*

Inventor:

*Arthur E. Whitney*  
by *N. P. Lombard*,  
Attorney.

A. E. WHITNEY.  
Leather-Splitting Machine.  
No. 209,001. Patented Oct. 15, 1878.

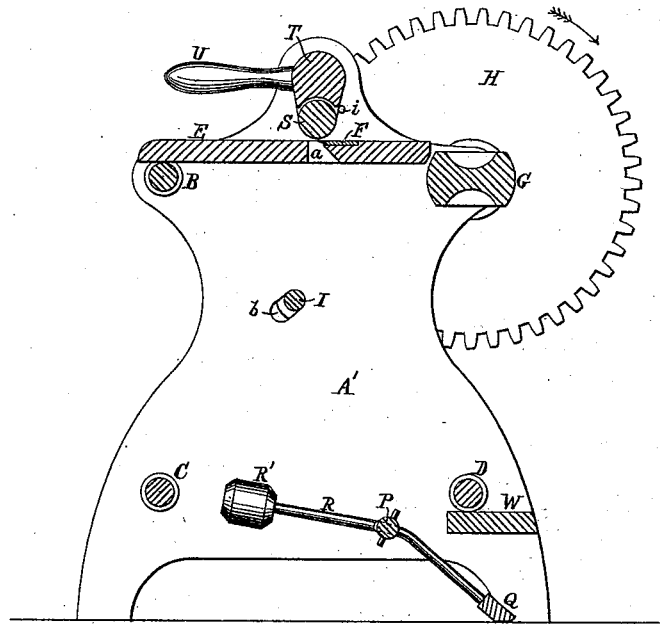

Fig. 4.

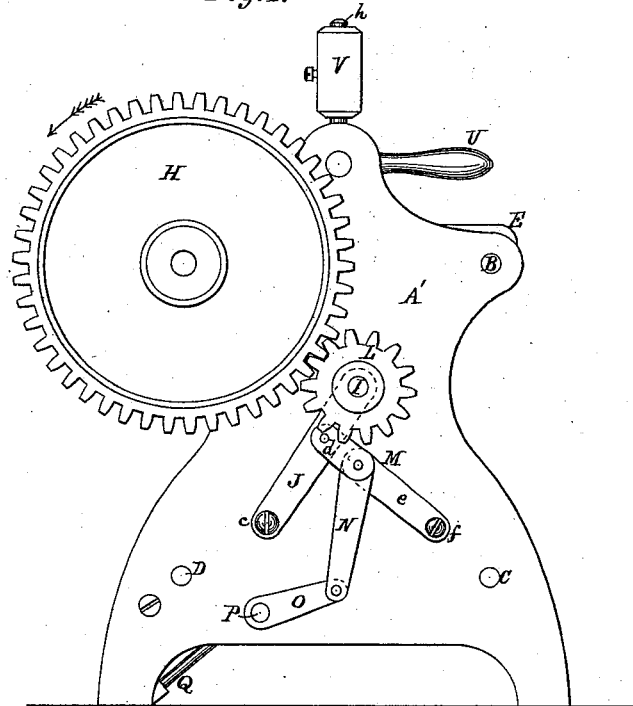

Fig. 3.

Witnesses:

*G. A. Hemmenway*  
*A. E. Whitney*

Inventor:

*Arthur E. Whitney*  
by *N. P. Lombard*  
Attorney.

# UNITED STATES PATENT OFFICE.

ARTHUR E. WHITNEY, OF WINCHESTER, MASSACHUSETTS.

## IMPROVEMENT IN LEATHER-SPLITTING MACHINES.

Specification forming part of Letters Patent No. 209,001, dated October 15, 1878; application filed April 11, 1878.

*To all whom it may concern:*

Be it known that I, ARTHUR E. WHITNEY, of Winchester, in the county of Middlesex and State of Massachusetts, have invented certain new and useful Improvements in Leather-Splitting Machines, of which the following, taken in connection with the accompanying drawings, is a specification.

My invention relates to that class of leather-splitting machines in which the leather is drawn through the machine against the edge of a stationary or fixed knife by being wound around a revolving beam, and has for its object the production of a machine that may be more easily operated than the machines of the class now and heretofore in use, and to remove in a great measure, if not entirely, the liability of accidental injury to the operator in the use of such machines, which has heretofore been a great objection to this class of machines.

My invention consists, first, in a peculiar arrangement of the mechanism by which the rotating beam is thrown into and out of gear with the driving-shaft, as will be further described.

My invention further consists in the use, in combination with an eccentrically-hung gage-roll, of a counterbalance-weight applied thereto to render said roll more easy of operation.

Figure 1 of the drawings is a plan of a machine embodying my improvements. Fig. 2 is a front elevation, Fig. 3 an end elevation, and Fig. 4 a vertical transverse section, of the same on line *x x* on Figs. 1 and 2.

*A A'* are the end frames of the machine, connected together by the tie-rods or girts *B*, *C*, and *D*, and the table *E*, provided with the longitudinal slot or throat *a*, and having secured to its upper side the knife *F*, all in a well-known manner.

*G* is a beam, having a cross-section substantially as shown in Fig. 4, and mounted in bearings in the frames *A A'* in such a manner that it may be revolved therein, and having secured to one of its ends outside of the frame *A'*, the large spur-gear wheel *H*.

*I* is the driving-shaft, having one bearing in the frame *A* and another in the radius-arm *J*, said shaft passing through a slot, *b*, in the frame *A'*, and having secured to one end thereof

the driving-pulley *K*, and to the other end the spur-pinion *L*, adapted to engage with the gear-wheel *H* to impart a rotary motion to the beam *G*.

The radius-arm *J* extends obliquely downward from the shaft *I*, and is pivoted at *c* to the frame *A'*, in such a position that its movable end may move to engage or disengage the pinion *L* with the gear *H* in a line substantially radial to the axis of the gear *H*, so that the weight of the shaft *I* and pinion *L*, as well as the radius-arm *J*, shall tend to throw the pinion *L* out of gear with the wheel *H*.

The radius-arm *J* has pivoted thereto one end of the link *d*, the other end of which is pivoted to the link *e*, the opposite end of which is pivoted at *f* to the frame *A'*, said links *d* and *e* together forming a toggle, *M*, the center joint of which is connected one end of the connecting-rod *N*, the opposite end of which is pivoted to the movable end of the lever *O*, secured upon the end of the rocker-shaft *P*, mounted in suitable bearings in the frames *A A'*, and carrying upon its front side the treadle *Q*, and projecting from its rear side the arm *R*, having mounted thereon the counterbalance-weight *R'*.

*S* is the gage-roll, mounted in bearings *g g* in the beam *T*, which is provided with journals eccentric to the axis of the roll *S*, which journals are fitted to bearings in the frames *A A'*, so that by giving a half-revolution to the beam *T* the roll *S* will be removed from contact with the stock and carried to the upper side of the beam *T*, thus opening a free space for the introduction of the stock to be acted upon. This beam *T* in a machine adapted to split a whole side of leather is necessarily made very heavy, and the roll *S* is also very heavy, so that, in order to turn said roll up, a lever or handle, *U*, is attached to and projects from the rear side of the beam, as shown in Figs. 1 and 3.

To reduce the labor of operating the beam *T*, *I* attach to the opposite end thereof the radius-arm *h*, upon which is secured, so as to be adjustable thereon, the weight *V*, to counterbalance the weighted side of the beam *T* and the roll *S*.

The beam T, when in position to gage the thickness of the stock, rests against the stops *ii*, which prevents the roll S and beam T from being drawn too far forward by the draft of the leather thereon.

W is a flat plate girt, placed above the treadle Q a distance just sufficient to allow space between it and the treadle, when the latter is in its highest position, to allow the operator to place the toe of his boot upon the treadle, and placed in such a position horizontally relatively to said treadle that any object falling from above cannot strike the treadle, and thus start the machine.

The operation of my improved machine is as follows: The handle U is first brought to the front side of the machine, turning the beam T the other side up, carrying the roll S with it, when the end of a side of leather is passed under said beam till it can be folded or wrapped partially around the beam G, pressing it with the fingers of both hands into the recess in the under side of said beam. The operator then turns the beam T back till the roll S rests upon the leather directly over the edge of the knife F, with the beam T bearing against the stops *ii*, when he places his foot upon the treadle Q and presses it downward till it strikes the floor. This movement of the treadle, acting through the rocker-shaft P, lever O, connecting-rod N, and the toggle-joint M, causes the movable end of the radius-arm J to be moved toward the axis of the beam G and the pinion L to engage with the wheel H, and thereby cause the beam G to be rotated in the direction indicated by the arrow, which revolution causes the leather to be wound upon said beam, and thus be drawn under the gage-roll S against the edge of the knife F, which reduces the leather to the desired thickness.

When the beam G first begins to revolve, the operator is obliged to hold the end of the side of leather to the beam, and at a certain point, when it is wrapped entirely around said beam, he is obliged, by a skillful manipulation, to perform the operation of "tucking," so called, which consists in tucking the end of the skin between the beam and that portion of the skin which is just being laid upon the beam. This operation has to be performed while the beam G is revolving rapidly, and unless the operator is very expert and also very careful his fingers will be caught, and unless the motion of the beam is instantly arrested his arm is very likely to be broken; hence the importance of so arranging and constructing the driving mechanism and the devices for throwing it into and out of gear with the draft-beam that the motion of the beam will cease the instant that the operator's foot is removed from the treadle.

Machines of this class that have been in almost universal use in tanneries for the last twenty or more years have been so constructed

and the driving-pinion so hung that if it became necessary to arrest the motion of the draft-beam when the strain of drawing the leather was upon it—as, for instance, in the case of the operator getting his fingers caught—it often required the whole weight of a heavy man upon the treadle to throw the pinion out of gear, because the path of movement of said pinion in moving out of gear was in a direction diagonally across the teeth of the wheel on the draft-beam, and in the direction that compelled the beam to be moved still farther in its forward motion before the pinion could be withdrawn therefrom, the consequence of which has been a great many broken bones.

My improvements entirely overcome this difficulty, as the pinion, in its movement to engage or disengage with the larger wheel, moves in a direction radial to the axis of said larger wheel, and the parts are so arranged that the weight of the movable end of the driving-shaft, the pinion, radius-arm, toggle, connecting-rod, and counterbalance-weight all tend, by virtue of the force of gravity, to cause the disengagement of the pinion from the larger wheel the instant that the operator's foot is removed from the treadle; and hence it is next to impossible for the operator to be seriously injured in my improved machine, as as all he has to do to release his fingers in case they get caught is to remove his foot from the treadle, and this is invariably the first act of the operator, performed, as it were, almost unconsciously in his effort to release or withdraw his fingers, as in order to pull his fingers from under the leather he steps backward and drops upon his knees.

What I claim as new, and desire to secure by Letters Patent of the United States, is—

1. In combination with a fixed or stationary knife, a gage-roll, a draft-beam adapted to be rotated and draw the leather through the machine by winding the leather thereon, and provided with a spur-gear wheel, secured thereon, and a driving-shaft provided with a pinion adapted to engage with or be disengaged from said spur-wheel, the radius-arm J, toggle M, connecting-rod N, lever O, rock-shaft P, and treadle Q, all arranged and adapted to operate as set forth, so that the weight of the parts shall tend to throw the pinion out of gear and raise the treadle, substantially as described.

2. The combination, in a leather-splitting machine, of the beam G, gear-wheel H, the driving-shaft I, provided with the pinion L, and adapted to be moved to cause said pinion to engage with or be disengaged from the wheel H, the radius-arm J, forming at one end the bearing for the movable end of said driving-shaft, and pivoted at its other end to the frame or some other fixed part of the machine, in such a position that a movement of its movable end shall cause the pinion to move in a line radial to the axis of the gear H, the

toggle M, connecting-rod N, lever O, rocker-shaft P, treadle Q, and counterbalance-weight R R', all arranged relative to each other, and adapted to operate substantially as and for the purposes described.

3. The combination of the beam T, gage-roll S, handle U, and counterbalance-weight V, all constructed, arranged, and adapted to

operate substantially as and for the purposes described.

Executed at Boston, Massachusetts, this 8th day of April, A. D. 1878.

ARTHUR E. WHITNEY.

Witnesses:

N. C. LOMBARD,

E. A. HEMMENWAY.