

W. G. A. BONWILL.
Electro-Magnetic Dental-Pluggers.

No. 209,006.

Patented Oct. 15, 1878.

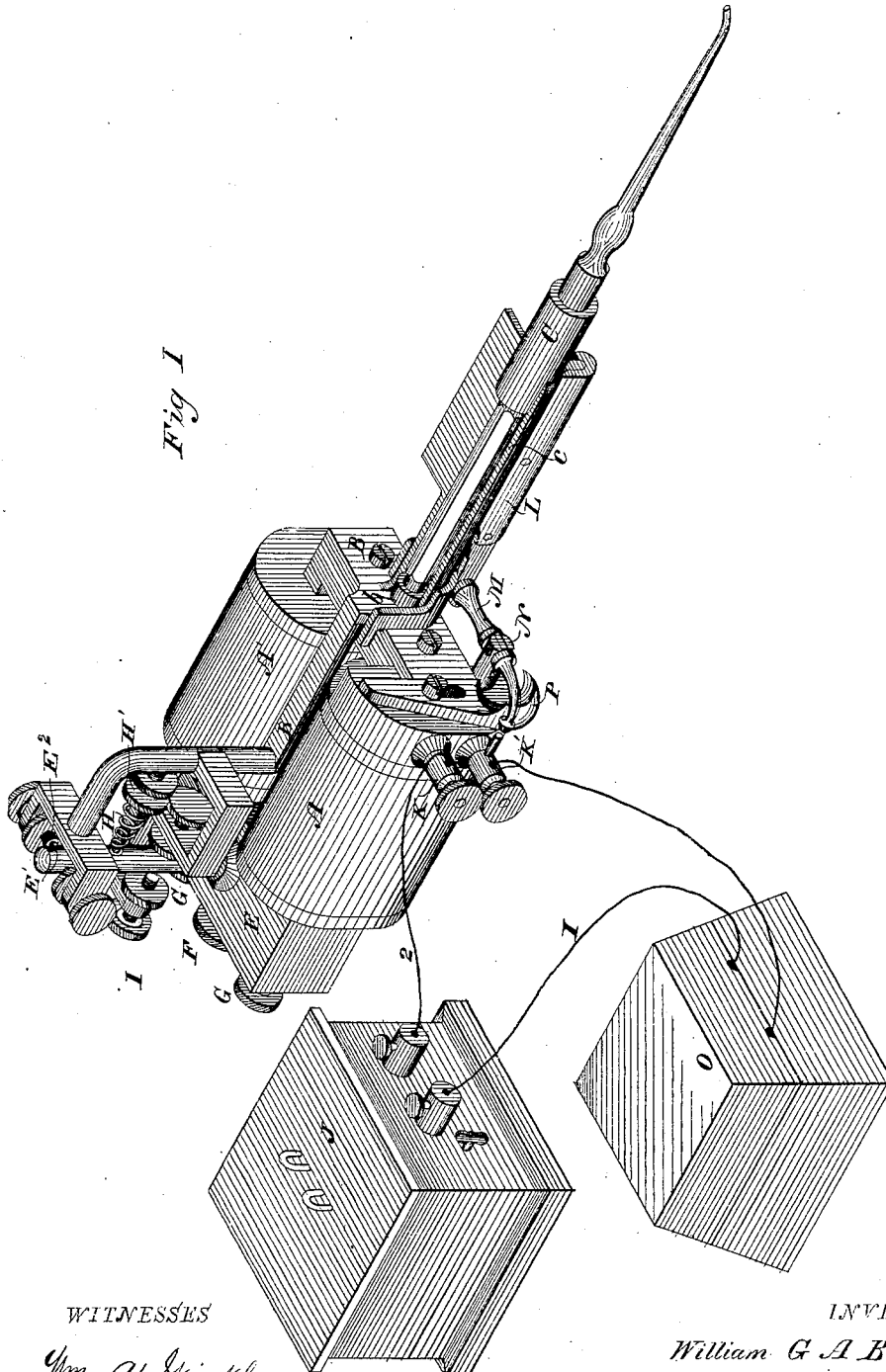

Fig 1

WITNESSES

Wm. A. Skinkle
Geo. W. Breck

INVENTOR

William G. A. Bonwill

By *his* Attorneys.

Howson and Son

W. G. A. BONWILL.
Electro-Magnetic Dental-Pluggers.

No. 209,006.

Patented Oct. 15, 1878.

Fig 2.

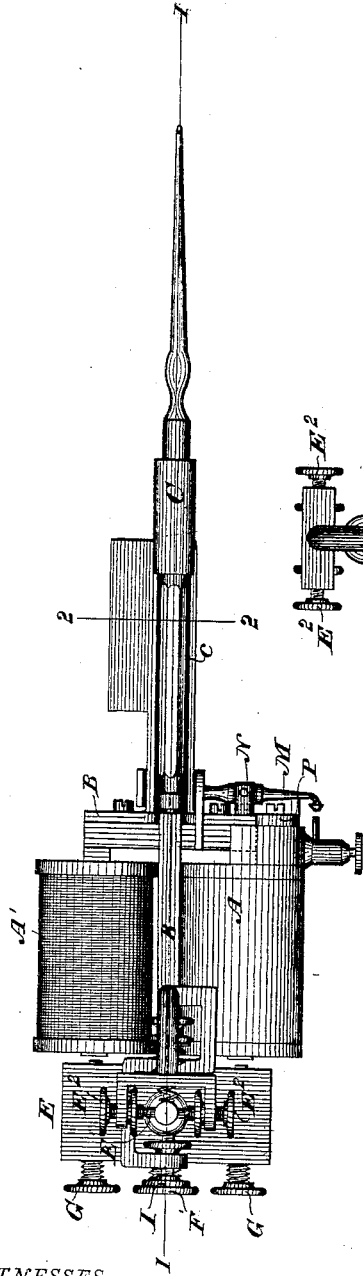

Fig A

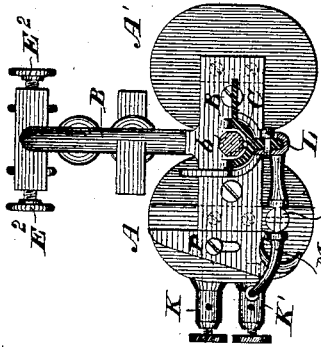
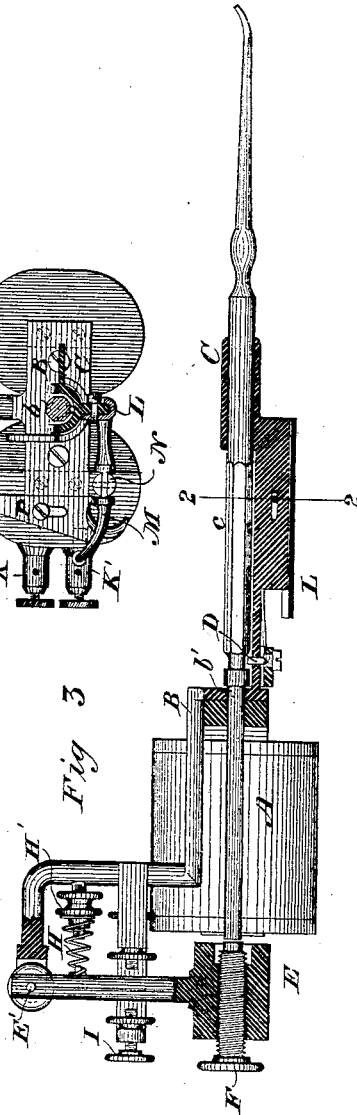

Fig 3



WITNESSES

Wm. A. Skinkle
Geo. W. Brock

INVENTOR

William G A Bonwill

By *his* Attorneys

Howson and Son

W. G. A. BONWILL.
Electro-Magnetic Dental-Pluggers.

No. 209,006.

Patented Oct. 15, 1878.

Fig 5.

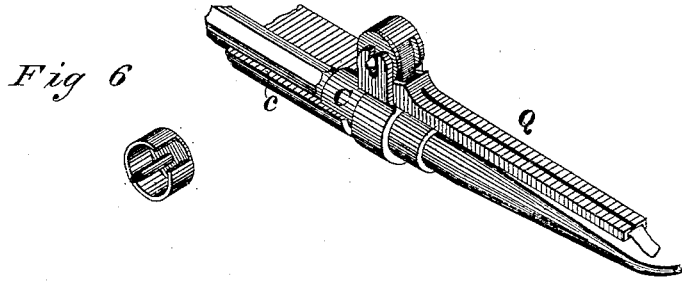
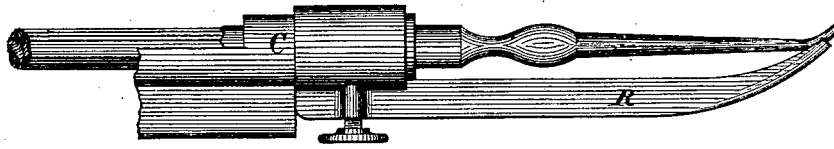

Fig 6



Fig 7



WITNESSES

Wm A Stinkle
George W Brecht

INVENTOR

William G A Bonwill.

By his Attorneys

Howson and Son

UNITED STATES PATENT OFFICE.

WILLIAM G. A. BONWILL, OF DOVER, DELAWARE, ASSIGNOR TO SAMUEL S. WHITE, OF PHILADELPHIA, PENNSYLVANIA.

IMPROVEMENT IN ELECTRO-MAGNETIC DENTAL PLUGGERS.

Specification forming part of Letters Patent No. 209,006, dated October 15, 1878; application filed November 14, 1871.

To all whom it may concern:

Be it known that I, WILLIAM G. A. BONWILL, of Dover, in the county of Kent and State of Delaware, have invented certain new and useful Improvements in Electro-Magnetic Dental Pluggers, of which the following is a specification:

My invention relates to improvements in dental instruments for plugging teeth of that class in which electricity is employed as a motor. Its objects and the subject-matter claimed hereinafter specifically will be designated.

In the accompanying drawings, which show all my improvements as embodied in one machine, Figure 1 is a perspective view of the instrument and its connections; Fig. 2, a top or plan view; Fig. 3, a vertical longitudinal section through the device on the line 1 1 of Fig. 2; Fig. 4, a cross-section therethrough on the line 2 2 of Figs. 2 and 3; Fig. 5, a view of an automatic feed for supplying tape-foil to the plugger-point; Fig. 6, a view of the bobbin or spool thereof detached, and Fig. 7 a view of a deflector for changing the direction of the plugger-point when a blow is received.

An ordinary electro-magnet composed of two coils, A A', is connected by its cross-bar to the frame B of the instrument. This frame B, from its point of attachment to the cross-bar of the magnet, extends backward between the coils thereof, and then rises above them, as clearly shown in the drawings.

The plugger-socket C, forming a portion or continuation of the frame B, has its bore in line with a central hole, *b*, in the cross-bar of a magnet, so that the shank of the tool, when inserted in its socket, may be passed between the coils of the magnet and project a short distance beyond its face to receive blows from a vibrating armature or mallet. (See Fig. 3.) The tool is securely held in the socket by means of a spring-pin, D, taking into a groove in its shank, which pin admits of the ready removal or insertion of the tool. The socket is open or cut away at the point *c*, to enable the plugging-tool to be revolved by the thumb of the operator during the working of the instrument.

A mallet or hammer, E, constituting the armature of the electro-magnet, is suspended

from the frame, which rises above the magnet, by means of a cross-head, E', rocking in bearings in adjustable centering-screws E², and is so arranged as to vibrate and strike the end of the plugging-tool, when attracted by the magnet, through the medium of a set-screw, F, passing centrally through the mallet-head or hammer. This screw is provided with an end piece of hard rubber or some other suitable material, to deaden the sound of the blows administered by it to the tool.

Set-screws G G are also passed through the mallet-head, one on each side of the center screw, and are so adjusted as to strike upon the helices of the magnet immediately after a blow has been imparted to the tool by the center screw, thereby preventing the armature or mallet from coming in direct contact with the magnet. These screws are also provided with cushioned heads similar to the center screw, in order to render the blows noiseless, and may be so adjusted as to allow the mallet or armature to approach very near without actually touching the magnet, and thus enable blows of full power to be administered.

The armature or mallet is separated from or held from contact with the magnet by means of a coiled spring, H, one end of which bears against the armature-handle and the other against a set-screw, H', mounted on the frame, the armature closing or vibrating inwardly toward the magnet only when the circuit is closed. By adjusting the tension of this spring the force of the blow administered by the mallet is regulated.

A set-screw, I, mounted in an extension or arm of the frame, may be adjusted to regulate the throw or play of the hammer or mallet, and consequently the strength of the blow given to the tool.

In order to vibrate the armature or mallet, a circuit-breaker is necessary, and in this instance I make use of a clock-work circuit-breaker, J, of well-known construction, detached from the instrument, which may be so adjusted as automatically to make and break the circuit with any desired degree of rapidity.

To place the instrument completely under the control of the operator, I mount upon the instrument itself, in a position convenient to his

fingers, a key or lever, M, through which the current passes, and by the movement of which the circuit may be made or broken and the instrument thrown into or out of operation. The key or lever is pivoted at its center to an insulated post, N, secured in the head of the helix A, and is controlled by a slide or finger-piece, L, movable endwise upon a flange on the frame, the finger-piece being jointed to one end of the lever or key, the opposite end of which carries a platina point, adapted to rest against a similar point upon the binding-post K' when the circuit is complete. The battery-wires are connected to binding-posts K K' in the usual manner.

The current of electricity passes from the battery O, through wire 1, to the automatic clock-work circuit-breaking mechanism J, the wires being connected up in the usual manner, thence through wire 2 to the binding-post K, thence through the coils of the magnet, in the usual manner, to the post N, thence through the key or lever M to the binding-post K', and from thence to the battery through wire 3.

It will be understood that every make and break in the circuit by the clock-work mechanism causes a vibration of the armature or mallet and a blow to be given to the plugging-tool.

The instrument may be thrown into or out of operation at the will of the operator by means of the finger key or lever before described, which thus places it completely under control.

When the instrument is not in use the circuit is permanently broken by a wedge, P, mounted upon the magnet, which may be forced down to separate and prevent contact of the lever M with the binding-post K'.

I have shown in Figs. 5 and 6 of the drawing an automatic tape-foil feeder, Q, adapted to my improved plugger, consisting of a suitable bobbin or spool, carrying a coil of the gold-tape, mounted in a frame adapted to be slipped upon the instrument, the tape passing through a slotted guide-tube to the plugger-point, which takes it up when the mallet is quiet.

I have also shown in Fig. 7 a deflector, R, adapted for attachment to the instrument, for changing the point of the plugger, when a blow is given, from a straight line to one of ninety degrees, for an obvious purpose.

I claim as of my own invention—

1. The combination of an electro-magnet, a frame mounted thereon, extending between the coils and rising above the magnet, and a vibrating armature or mallet suspended from said frame, substantially as described.

2. The combination of the electro-magnet, its cross-bar, and the plugger-socket, the cross-bar being provided with a central aperture in line with the bore of the socket, whereby the plugger-shank may be passed through both socket and cross-bar and between the coils of the magnet, to be acted upon by the armature of the magnet.

3. The combination of an electro-magnet with an armature or mallet, provided with a set-screw to strike upon a plugging-tool, substantially as described.

4. The combination of an electro-magnet, a vibrating armature or mallet, and set-screws to prevent direct contact of the mallet and magnet, substantially as described.

5. The combination of the electro-magnet, the frame, the mallet, and a set-screw carried by the frame for regulating the throw or play of the mallet, substantially as described.

6. The combination of the electro-magnet, the frame rising above the magnet, the armature or mallet suspended from the frame, and a spring located between the mallet and the frame to throw the mallet outward when the electric circuit is broken, substantially as described.

7. The combination of the frame, a mallet carried thereby, the open or slotted tool-socket, and a plugging-tool, whereby the tool may be revolved during the operation of the instrument by the hand of the operator.

8. A finger-key consisting of a pivoted lever mounted upon the frame of the instrument, to make and break the circuit, substantially as described.

9. The combination, with the circuit making and breaking key or lever, of a wedge or device acting on the key to permanently open the circuit when the instrument is not in use, substantially as described.

10. The combination, in an electro-magnetic dental plugger, of an electro-magnet, a frame mounted thereon, a vibrating armature or mallet suspended from the frame and adapted to impart blows to a plugging-tool, an automatic circuit-breaker, disconnected from the instrument, and a temporary circuit-breaker mounted on the instrument itself and under the complete control of the operator, substantially as described.

WM. G. A. BONWILL.

Witnesses:

JOHN URIAN,
SAML. P. JONES, Jr.