

W. R. HALLETT.
Adjustable Reel for Reapers.

No. 209,120.

Patented Oct. 22, 1878.

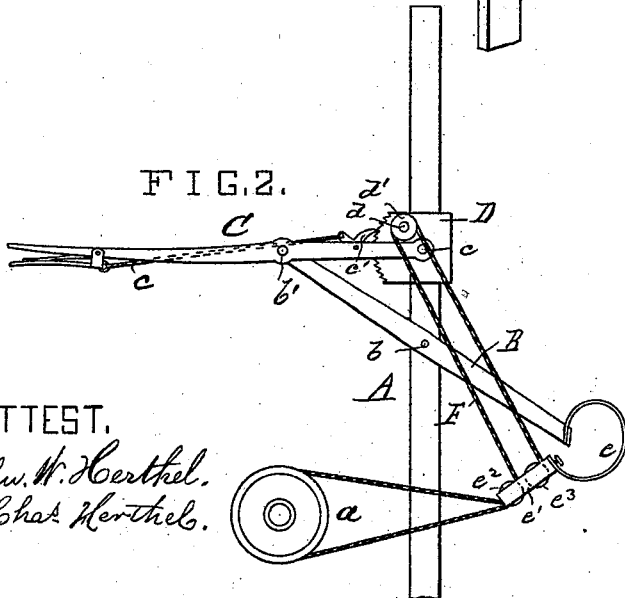
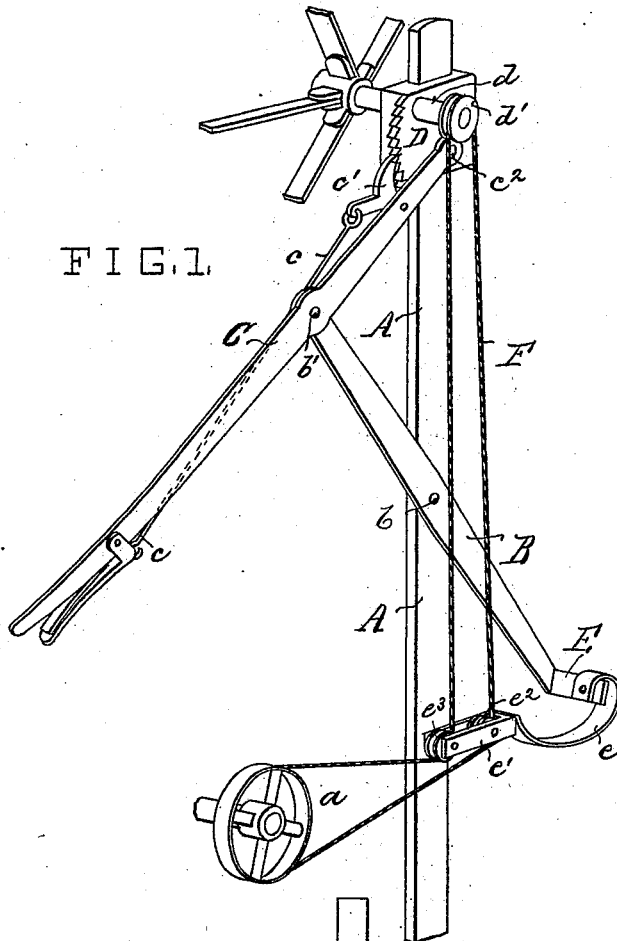

ATTEST,
John W. Herthel,
Chas. Herthel.

INVENTOR,
William R. Hallett
per Herthel & Co

UNITED STATES PATENT OFFICE.

WILLIAM R. HALLETT, OF BRUSSELS, ILLINOIS.

IMPROVEMENT IN ADJUSTABLE REELS FOR REAPERS.

Specification forming part of Letters Patent No. 209,120, dated October 22, 1878; application filed September 9, 1878.

To all whom it may concern:

Be it known that I, WILLIAM R. HALLETT, of Brussels, Calhoun county, State of Illinois, have invented an Improved Adjustable Reel for Reapers, of which the following is a specification:

It is well known that reaping-machines have a reel attachment, to reel the grain into proper position for the action of the sickle. The reel, further, is adjustable for purposes of suiting high or low grain, and holding the same properly to be cut.

My invention relates to this class of adjustable reels, and I will now fully describe the construction and operation of the same, and hereinafter point out the novel features thereof in the claims.

Of the drawings, Figure 1 is a perspective view of my improvement, the parts being adjusted near the top of the reel-post. Fig. 2 is a side elevation, showing the parts adjusted to a lower position on the reel-post.

A is the ordinary stationary reel-post. *a* represents the usual gear or pulley connection with the axle of the reaper.

My invention relates chiefly to the improved combination of lever attachments that adjust the reel directly along the reel-post, and in so doing at the same time tighten the chain to properly drive or rotate the reel.

B is a main lever, which I pivot at *b* to the reel-post. The said lever B carries at its lower end the parts that tighten the chain. The upper end of the said lever is pivoted at *b'*, to be operated by the hand attachment C. The hand attachment C consists of the hand-lever proper, alongside of which is a spring-rod, *e*, actuating the pivoted pawl *e'*. (See figures.)

The hand-lever extends within reach of the driver, and has its fulcrum at *e²* on a sliding bracket, D. The bracket D has a slot through which the reel-post passes, and this being secured perpendicularly, the said bracket can slide vertically along said post.

Further, the sliding bracket has the notches for the engagement of the pawl, and it is by means of the engagement or disengagement of said pawl from the sliding bracket that the same can be freely adjusted and secured in adjusted position along the reel-post.

The sliding bracket D has the shaft *d*, and

this carries at one end the reel proper, while the other end of the shaft has the pulley *d'*, for the passage of the upper part of the chain.

From the lower end of the lever B projects sidewise the arm E. To this one end of a curved spring, *e*, is secured, the other end being secured to the pulley-frame *e'*, in which two pulleys, *e²* *e³*, turn. F is the endless chain. It passes over the driving-pulley *a*, and, each line of the chain passing up the side of the respective pulleys *e²* *e³*, the upper end of the chain is finally passed over the pulley on the reel-shaft, as shown.

The parts being thus constructed and arranged, the operation is as follows: By disengaging the pawl from the notches or teeth and raising the hand attachment C, the bracket carrying the reel is lowered, and the parts can be made to assume the position shown in Fig. 2. By lowering the hand attachment, the parts can be restored to the position shown in Fig. 1. The vertical adjustment of the reel, therefore, takes place along the reel-post, and the said adjustment is so precise and decisive that at all times the reel can be properly positioned to suit the requirements of the case. Specially it will be noted that the same movement of the parts to adjust the reel also keeps the driving-chain taut, and this need not therefore be lengthened or shortened or hooked together to accommodate the adjustment. The only crook in the chain takes place when the reel is lowered, (see Fig. 2,) and I require but two pulleys below.

Further, the parts that operate the reel, as well as the latter, are in my case supported in a most steady, firm, and durable manner, in contradistinction to the shaky and unreliable action that characterizes the supporting parts and operation of former reels.

By means of the hand attachment C the driver can instantly, without stopping the team, drop the reel or raise it, and keep it at the desired point, avoid imperfect reeling, and also avoid pitching the grain back over the platform. As apparent, my improvement can be applied to rear or front cutting reaping-machines.

What I claim is—

1. The bracket D, having notches and a slot, by means of the latter to engage the reel-post,

the lever attachments B C, the latter having spring-rod and pawl, all said parts being combined, as shown and described, by means whereof the adjustment of said bracket takes place, in the manner and for the purposes set forth.

2. In combination with a reel-post, sliding bracket D, and pulley d' , the main lever B, carrying the arm E, spring e , pulley-frame e^1 , pulleys $e^2 e^3$, and endless chain, by means whereof the said chain can be kept taut, in the manner and for the purposes set forth.

3. The main lever B, carrying the spring e ,

pulleys $e^2 e^3$, the hand attachment C, the sliding bracket D, carrying reel-shaft and pulley d' , and the endless chain, all said parts being combined to operate on a reel-post, in the manner and for the purposes set forth.

In testimony of said invention I have hereunto set my hand.

WILLIAM R. HALLETT.

Witnesses:

WILLIAM W. HERTHEL,
JOHN W. HERTHEL.