

J. KEITH.

Wax-Thread Sewing-Machine.

No. 209,126.

Patented Oct. 22. 1878.

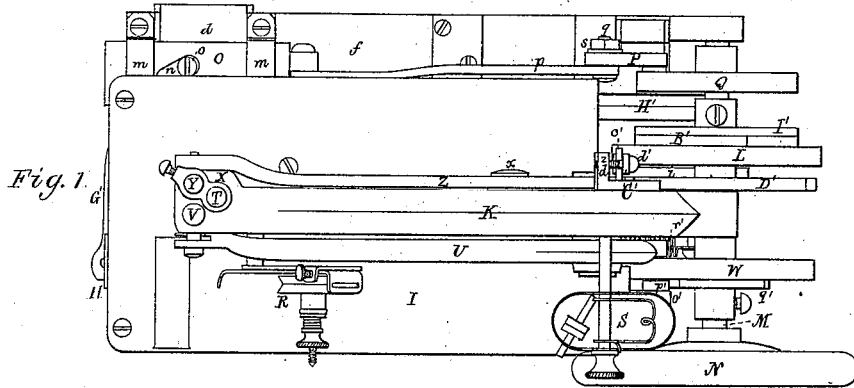

Fig. 1.

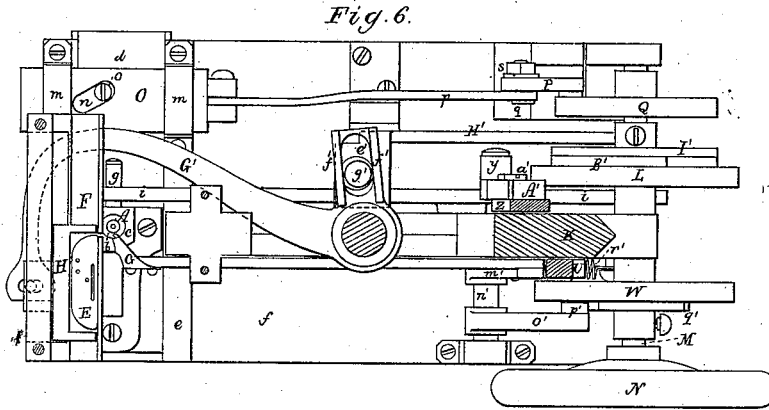

Fig. 6.

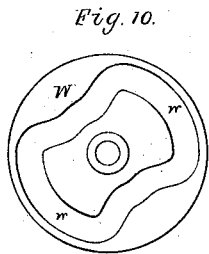

Fig. 10.

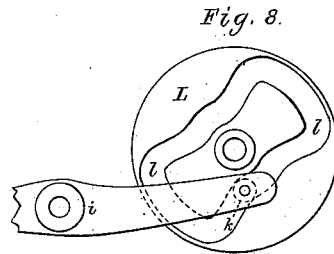

Fig. 8.

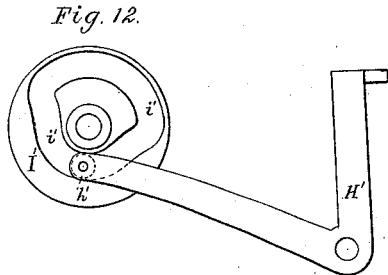
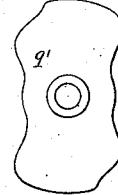

Fig. 12.

Fig. 14.



Witnesses  
*S. N. Piper*  
*L. V. Miller*

*Inventor*  
 Jeremiah Keith.  
 by his attorney  
*R. H. Eddy*

J. KEITH.  
Wax-Thread Sewing-Machine.  
No. 209,126. Patented Oct. 22, 1878.

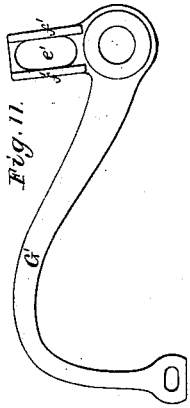

Fig. 11.

Fig. 9.

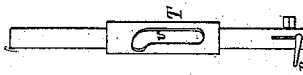

Fig. 3.

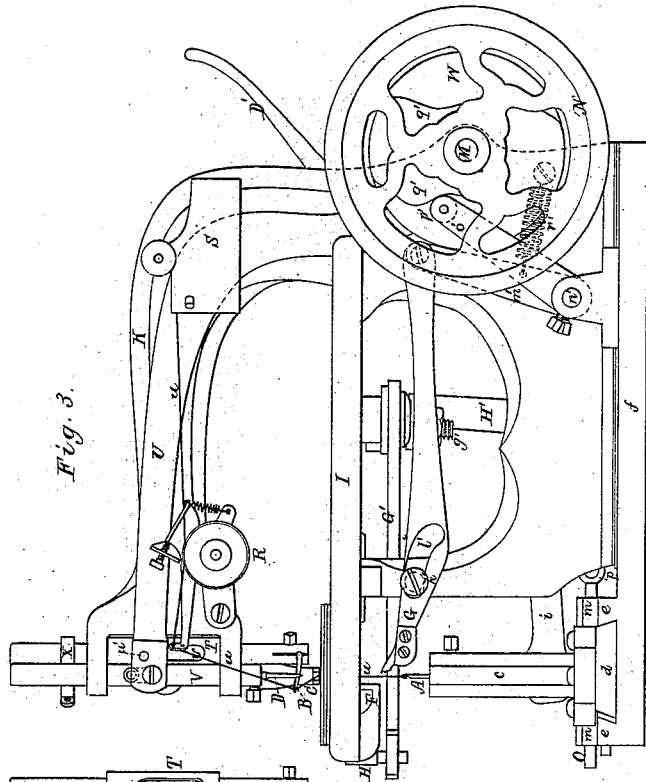

Fig. 2.

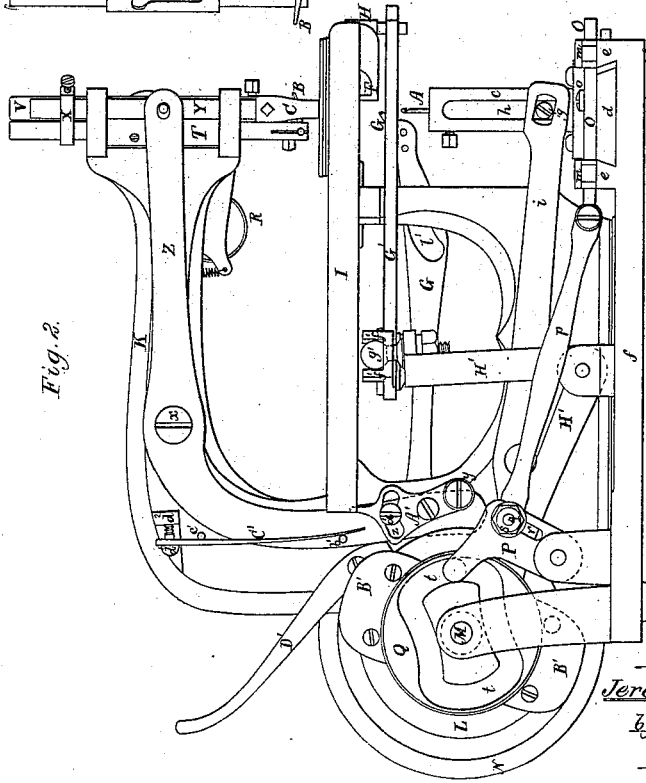

Fig. 13.



Witnesses.  
*S. M. Piper.*  
*L. W. Miller*

Inventor:  
*Jeremiah Keith.*  
by his attorney.  
*R. H. Eddy*

J. KEITH.  
Wax-Thread Sewing-Machine.  
No. 209,126. Patented Oct. 22, 1878.

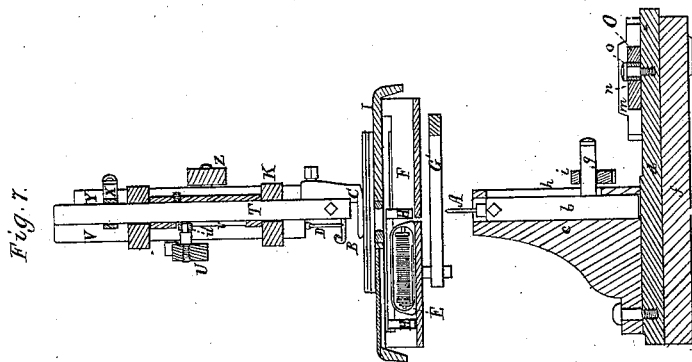

Fig. 7.

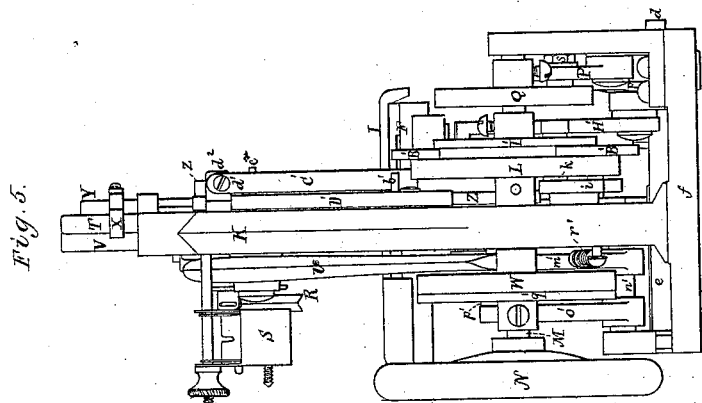

Fig. 5.

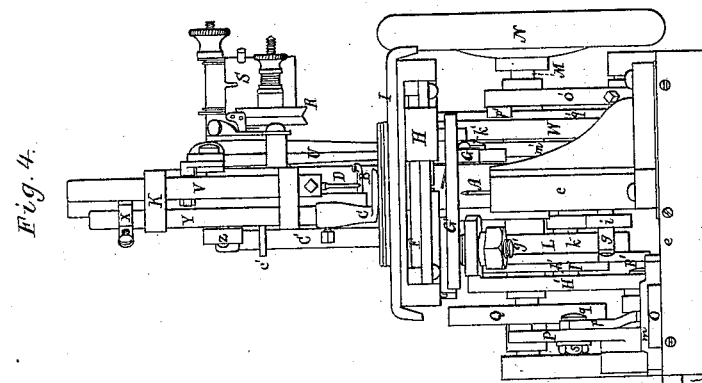

Fig. 4.

Witnesses  
*S. M. Piper*  
*L. W. Milled*

Inventor:  
*Jeremiah Keith*  
 by his attorney  
*R. H. Eddy*

# UNITED STATES PATENT OFFICE.

JEREMIAH KEITH, OF PROVIDENCE, RHODE ISLAND.

## IMPROVEMENT IN WAX-THREAD SEWING-MACHINES.

Specification forming part of Letters Patent No. **209,126**, dated October 22, 1878; application filed January 15, 1878.

*To all whom it may concern:*

Be it known that I, JEREMIAH KEITH, of the city and county of Providence, of the State of Rhode Island, have invented new and useful Improvements in Machinery for Wax-Thread Sewing; and do hereby declare the same to be described in the following specification and represented in the accompanying drawings, of which—

Figure 1 is a top view, Figs. 2 and 3 opposite side elevations, Fig. 4 a front-end elevation, and Fig. 5 a rear-end elevation, of a machine containing my invention. Fig. 6 is a horizontal section, showing the shuttle, its race, and the shuttle-driver. Fig. 7 is a vertical section, showing the needle and the shuttle-race and some of the adjacent parts. Such other figures as may be necessary to a clear illustration of such invention are hereinafter referred to and described.

The machine on which my invention is based, being specially adapted for sewing with a waxed thread, and consequently very useful in sewing articles composed in whole or in part of canvas or leather, has the following elements or instrumentalities in combination, and to operate substantially as set forth—that is to say, it has an awl to puncture the material to be sewed, a hooked or "hook" needle to aid in making the stitches and to feed the material along, a threader to lay the waxed thread into the hook of the needle, a loop opener or spreader and cast-off, a presser to hold the material in place while the needle and the awl may be passing into and out of it, and a double-nosed shuttle, as described, that during each of its reciprocating movements carries a binding-thread through a loop formed by the needle and the loop opener or spreader and cast-off—all such elements being arranged essentially in manner and having operative mechanism as hereinafter explained.

In the drawings, A denotes the hooked needle, B the threader, C the presser, D the awl, E the two-nosed shuttle, F the shuttle-race, G the loop-opener, H the shuttle-driver, I the table or frame, and K the goose-neck, of the machine.

The shuttle has a nose at each end, and by its operative mechanism it is caused, in every rectilinear movement of it through its race, to

pass through a loop formed by the needle and the spreader.

In the process of sewing, the shuttle passes forward or in one direction through the loop, and next backward or in the opposite direction through the next loop. This causes a somewhat different stitch to be formed from what results from the use of a single-nosed shuttle, always acting in one direction in passing through the several loops.

With the single-nosed shuttle running through the loops in the direction opposite to that in which the material is fed along there will be no coil or twist of the shuttle-thread around each loop, the binding-thread passing directly through each loop. When, however, the shuttle is two-nosed, and in each movement passes through a loop, the binding-thread will be coiled around the thread of every other loop, and will go directly through the intermediate loops without any such coiling around their threads.

The mechanism for actuating the hook-needle A may thus be described: The said needle extends upward from a carrier, *b*, arranged to move vertically in a standard, *c*, projecting upward from a plate, *d*. The said plate *d* is dovetailed in transverse section, and arranged between parallel guides *e e*, extending up from the base-plate *f* of the frame I.

From the needle-carrier a stud, *g*, is projected horizontally through a slot, *h*, made vertically in the standard *c*. Such stud goes loosely through a lever, *i*, arranged as represented; and pivoted to the frame. From the shorter arm of this lever a stud and a friction-roller, *k*, thereon are projected into the groove *l* of a cam, L. (See Fig. 8, which is an inner-side view of the cam and part of the lever, such figure also showing the stud and roller.) This cam is fixed on the driving-shaft M of the machine, which shaft, arranged as shown, is furnished with a fly-wheel, N.

By having the stud *g* to go loosely through the lever and to project from it in manner as represented, the lateral movements of the standard *c* can take place without causing any lateral draft on the lever, which remains in connection with the needle-carrier during either of such movements.

Extending directly across the plate *d*, at

right angles to it, is another slide-plate, O, arranged to move longitudinally and rectilinearly in stationary guides *m m*. This plate O has a slot, *n*, arranged in it obliquely. Into this slot a stud or screw, *o*, carrying a friction-roller, extends up from the slide-plate *d*.

A connecting-rod, *p*, jointed to the plate O, has at its rear part a joint-pin, *q*, (upon which it turns freely,) extended from it through a slot, *r*, arranged as shown, in an arm, P, pivoted at its lower part to the frame of the machine. The said joint-pin *q* is provided with a clamp-screw and nut, as shown at *s*, or suitable appliances to enable it to be adjusted and fixed higher or lower in the slot of the arm, as occasion may require, for varying the extent of rectilinear movement of the slide-plate O in order to vary the length of stitch to be made.

The arm P, at or near its upper end, has a stud and friction-roller, to enter the groove *t* of a cam, Q, fixed on the driving-shaft. The groove of the said cam, formed as represented, effects, while the cam is in revolution, the necessary movements of the plate O. While the said plate is in the act of being moved forward it will cause the plate *d* to be moved in a direction to cause the needle to advance or feed the work or material to be sewed the necessary distance for the formation of a stitch. A reverse motion of the plate O will effect a counter movement of the needle while it may be out of the work.

The threader B is a bent arm, having at its outer end or part a hole through it to receive the waxed thread *u*, supported by a suitable tension apparatus, R, and extended from a waxing-tank, S, arranged as shown. This threader projects from a vertical rotary spindle or carrier, T, suitably supported by, and so as to be capable of being partially revolved in, the goose-neck. It has an oblique groove, *v*, in it, (see Fig. 9, which is a side view of such carrier T,) to receive a stud, *w*, projecting inward from the bent lever U, for carrying and operating the awl D. While such lever U is in movement a rotary motion of the carrier T will be effected, whereby the thread-carrier will be moved so as to cause the waxed thread to be laid in the hook of the needle.

The lever U, suitably connected with the awl-carrier V, (which slides vertically on the goose-neck,) has a stud projecting from its lower arm into the groove *w* of a cam, W, fixed on the driving-shaft. Fig. 10 is an inner-side view of such cam W.

The carrier T slides through an arm, X, extending from and clamped to the carrier Y of the presser C. This carrier Y slides freely vertically in the goose-neck, and is pivoted to a lever, Z, whose fulcrum *x* projects from such goose-neck. The lower arm of the lever Z has pivoted to it a lever, A', whose lower arm is provided with a friction-roller, *y*, the upper arm of such lever having a curved slot, *z*, in it. A clamp-screw, *a'*, goes through the said slot and screws into the lever Z.

By means of the adjustable lever A' and its

clamp-screw, the degree of vertical upward movement of the presser may be varied as the thickness of the work to be sewed may require from time to time, such movements being due to the action of cams B' B', that project from the cam L, for effecting the movements of the needle. The cams B' B' are to work against the roller *y*.

A spring, C', resting against a stud, *b'*, projecting from the shorter arm of the lever Z, and also against another stud, *c'*, extending from the goose-neck, has a screw, *d'*, going through it above the stud *c'*, and being screwed into an ear, *d''*, extending from the goose-neck. This spring is to effect a counter or downward movement of the lever Z.

By means of the screw the pressure of the presser upon the work may be increased or diminished, as may be required in accordance with the thickness of the work or the resistance necessary to support the work against upward draft or pressure on it while the machine is in operation.

A lever, D', pivoted to the goose-neck, and arranged directly in rear of the shorter arm of the lever Z, is to enable a person to readily effect the raising of the presser off the work.

The double-nosed shuttle—that is, a shuttle pointed or properly formed at its ends, so as to pass either end foremost through a loop—is shown at E as arranged in its rectilinear race F, arranged beneath the work-support plate.

Such shuttle is placed in a shuttle-driver, H, which is pivoted to the longer arm of a lever, G', a top view of which is shown in Fig. 11. This lever, arranged beneath the work-support plate, is pivoted thereto and has a slot, *e'*, through its shorter arm. It also has two abutments, *f' f'*, raised upon such shorter arm, the slot being between them.

A spherical-headed bolt, *g'*, extends through the slot, has its head above such and between the abutments, the shank of the bolt being secured in the upper end of an acute angular lever, H', pivoted to the base-plate of the frame. The other arm of the said lever carries a friction-roller, *h'*, to engage with the slot *i'* of a cam, I', fixed on the driving-shaft. A side view of the lever and cam is given in Fig. 12.

By means of the cam and the two levers, connected as described, the shuttle-driver has imparted to it its proper movements for causing the shuttle, during each of its rectilinear movements, to pass through a loop—that is, the shuttle in being thrown or moved one way goes through one loop, and during the return movement it passes through the loop next formed, thereby laying its binding-thread through such loops successively.

The loop-opener shown at G, and more especially in top view in Fig. 13, works lengthwise upon a screw, *k'*, inserted in the frame and going through an angular slot, *l'*, made in the said loop-opener. This opener is not only to open and spread each loop, so as to enable the shuttle to pass through it, but is to cast such loop off the hook-needle. The angular

slot enables the loop-opener not only to spread the loop, but to raise it up sufficiently for the shuttle to pass through and clear of it, so as not to collect wax from the thread of the loop. At its rear end the loop-opener is jointed to an arm, *m'*, projecting up from a shaft, *n'*, from which another arm, *o'*, extends, as shown, and carries a friction-roller, *p'*, to bear against the periphery of a cam, *q'*, fastened on the driving-shaft, (see Fig. 14,) which is a side view of the cam. A spring, *r'*, fixed to the frame and to the arm *m'*, serves to effect counter movements of the loop-opener.

While the machine is in operation the awl punctures the work, after which the hook-needle rises up through a hole made in the work by the awl, and has the waxed thread laid in its hook. After this the needle descends and draws the loop through the material, and the loop-spreader is brought into action to spread the loop. Next the shuttle is thrown and carries its thread through the loop. While the needle is in the work the feeding of the latter by such needle takes place in due time. The tension apparatus operates in the usual way to cause the loop and the binding-thread to be drawn into the work.

What I claim as of my invention in the machine hereinbefore described, is as follows:

1. The combination for effecting and regulating the feed of the needle, such consisting of the grooved cam Q, the slotted arm P, the connecting-rod *p*, with the adjustable pin *q*, the obliquely-slotted slide-plate O, and the plate *d* and its stud *o* to enter the slot *n* of the plate O, all being arranged and applied to the driving-shaft, the frame, and the standard *c*, substantially as set forth.

2. In combination with the presser-carrier, the adjustable lever A' and its clamp-screw *a'*, the cams B' B', and the bent-lever Z, all being arranged and applied substantially as set forth.

3. In combination with the shuttle-driver H, the lever G', having the slot *e'* and abutments *f' f'*, the spherical-headed connection-bolt *g'*, the lever H', and the cam I', all arranged and applied substantially as specified.

4. The loop-opener G, having the angular slot *l'* and support pin or screw *k'*, in combination with the arms *m' o'*, shaft *n'*, cam *q'*, and spring *r'*, all being arranged and applied substantially as set forth.

JEREMIAH KEITH.

Witnesses:

H. S. BABCOCK,  
JEROME C. TAFT.