

W. S. McKENNA.
Annealing-Furnace.

No. 209,130.

Patented Oct. 22, 1878.

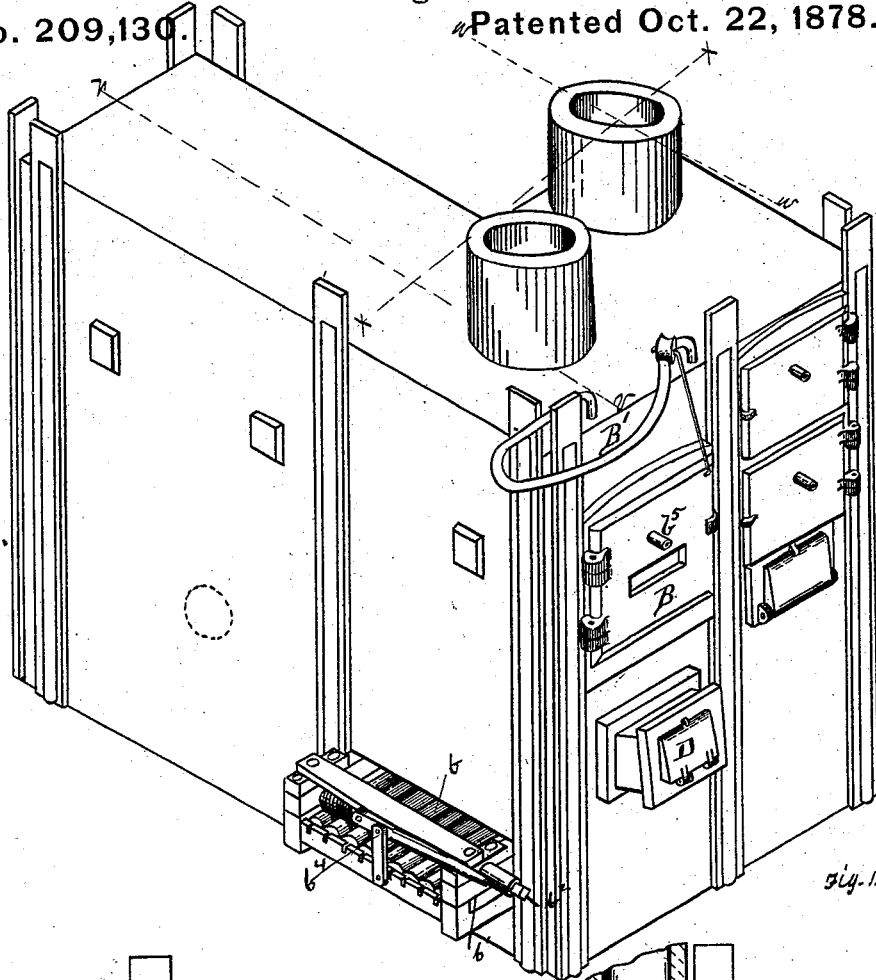

Fig. 1.

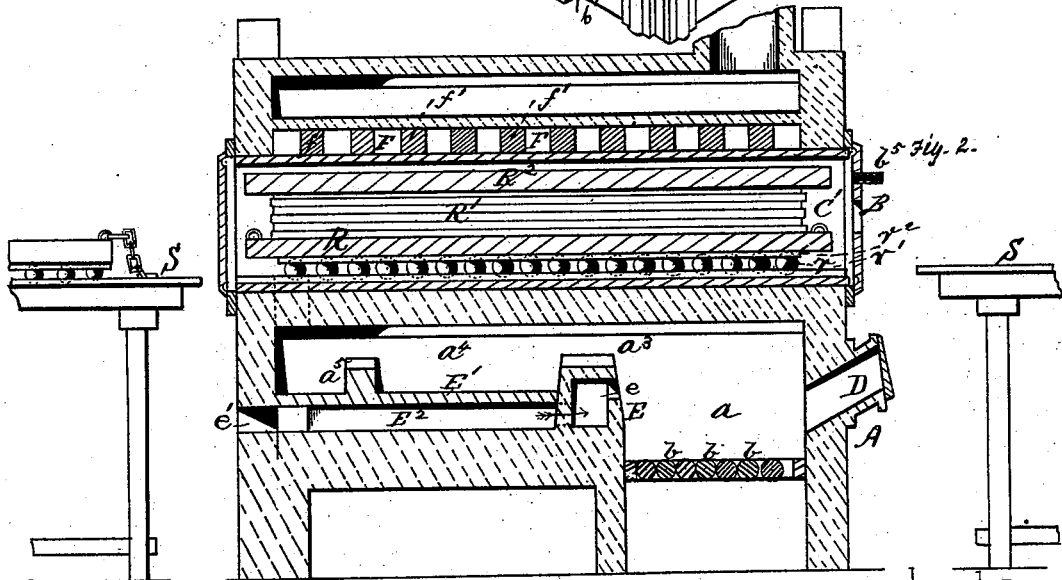

Fig. 2.

WITNESSES.
John H. Smith
J. F. Best

INVENTOR
William S. McKenna
By Baswell & Kerr Attys

W. S. McKENNA.
Annealing-Furnace.

No. 209,130.

Patented Oct. 22, 1878.

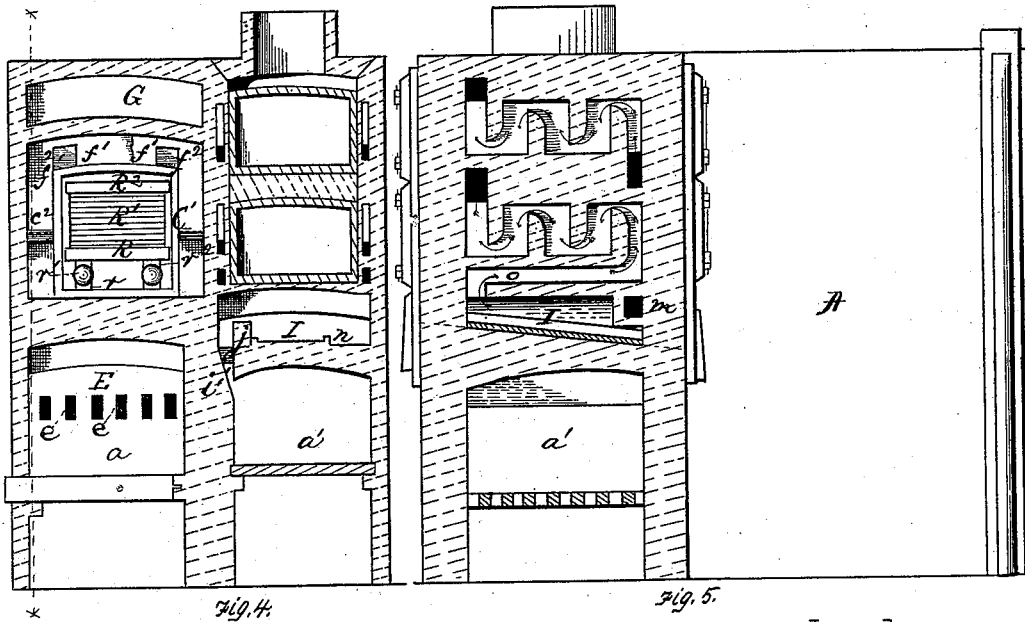
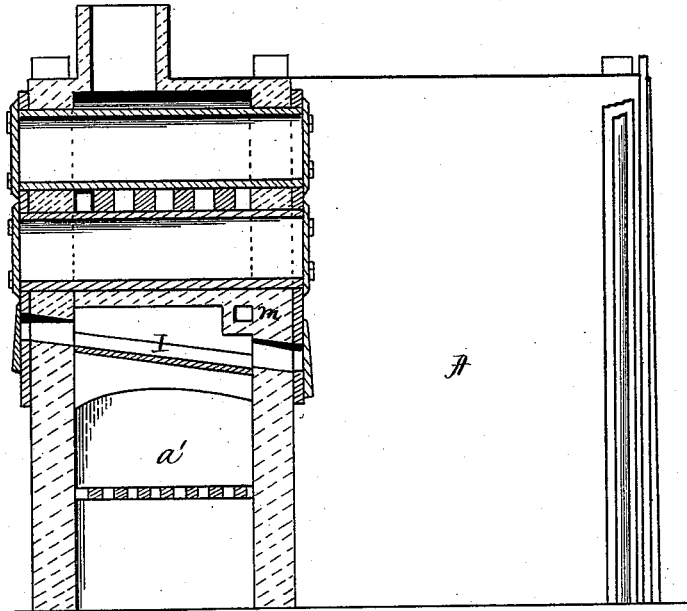

ADDRESSES.
J. W. Smith
J. F. Best

INVENTOR.
William S. McKenna
 By *Babewell & Kerr*
Attys.

W. S. McKENNA.
Annealing-Furnace.

No. 209,130.

Patented Oct. 22, 1878.

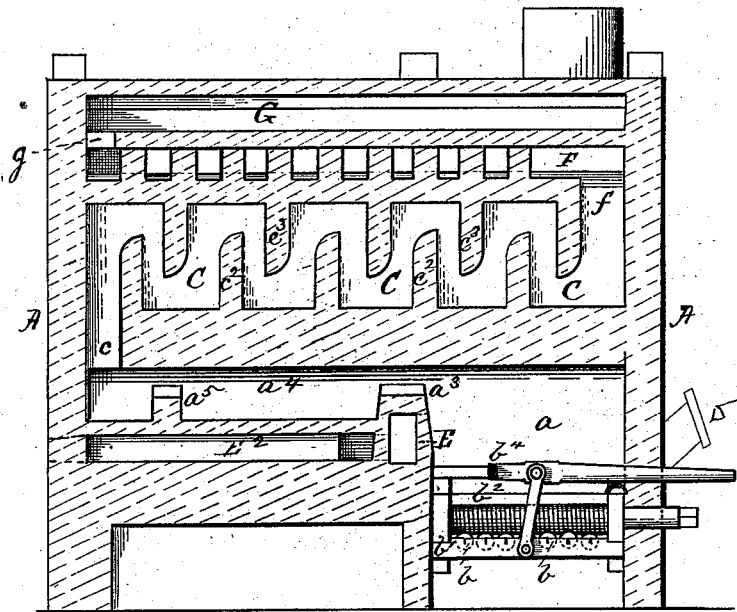

Fig. 6.

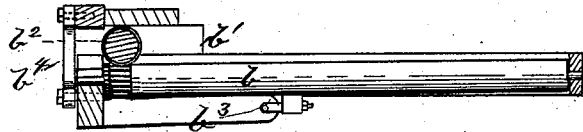

Fig. 7.

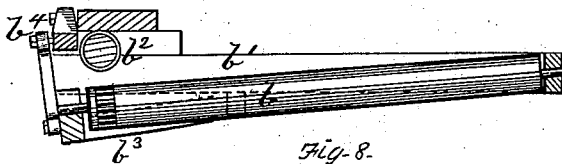

Fig. 8.

WITNESSES.
J. K. Smith
J. T. Best

INVENTOR.
William S. McKenna
By Bakewell & Kerr
attys

UNITED STATES PATENT OFFICE.

WILLIAM S. McKENNA, OF PITTSBURG, PENNSYLVANIA.

IMPROVEMENT IN ANNEALING-FURNACES.

Specification forming part of Letters Patent No. 209,130, dated October 22, 1878; application filed March 8, 1878.

To all whom it may concern:

Be it known that I, WILLIAM S. McKENNA, of Pittsburg, in the county of Allegheny and State of Pennsylvania, have invented a new and useful Improvement in Annealing-Furnaces; and I do hereby declare the following to be a full, clear, and exact description thereof, reference being had to the accompanying drawing, forming part of this specification, in which—

Figure 1 is a perspective view of a furnace embodying my invention. Fig. 2 is a vertical longitudinal section on the line *v v*, Fig. 1. Fig. 3 is a similar section on the line *w w*, Fig. 1. Fig. 4 is a vertical transverse section on the line *x x*, Fig. 1. Fig. 5 is a view of the rear side of the furnace, partly in section. Fig. 6 is a view of the near side of the furnace, as shown in Fig. 1, the side wall being broken away to show the interior. Figs. 7 and 8 are detached views of the grate, partly in section, showing the construction and operation thereof.

Like letters refer to like parts wherever they occur.

My invention relates to the construction and operation of annealing-furnaces employed in annealing iron, glass, &c.

It consists, first, in a grate composed of a series of journaled bars adapted to be revolved by a worm, or equivalent means, whereby the ashes, &c., can be displaced without violent agitation of the fire; second, in a grate composed of a series of a series of journaled bars adapted to be revolved by a worm, or equivalent means, to displace the fire, dust, and ashes, and having its frame, or a portion thereof, hinged so that the bars can be inclined or dropped at an angle for the removal of clinkers, &c.; third, in the combination, with grate and fire-bridge, of the inclined coal chute or feeder, arranged in the wall of the furnace at a point opposite the perforated hollow fire-bridge, whereby the proper feed of the fuel is insured, the chilling of the retorts obviated, choking of the retort-flues is prevented, and the retorts are consequently more effectually heated; fourth, in arranging in an annealing-furnace, and combining with the retort or retorts thereof, a series of cross-walls and projecting walls, which form a series of flues or

tortuous passages, for directing the products of combustion, &c., back and forth longitudinally of the retort, so as to retain them in contact therewith, whereby the retort is uniformly heated and guarded from sudden changes of temperature; fifth, in combining with the flue of an annealing-furnace, at a point between the grate or fire-chamber and the retort or retorts, an inclined hearth, adapted to present horseshoes or like articles to the action of the flame and products of combustion, whereby surplus grease, &c., may be removed; sixth, in combining with the retort door or doors of an annealing-furnace a telegraph or telegraphs, or curved elevated rail, secured to furnace, whereby the doors can be easily handled and opened and closed with little injury to the luting; and, finally, in details of construction, hereinafter more specifically set forth.

The specific construction and arrangement shown in the drawing is such as is most desirable in an annealing-furnace for works manufacturing specialties, such as nails, horseshoes, sheet-iron, &c., and is adapted to treating the articles in bulk; but it will be readily apparent that many of the arrangements and combinations are of use in annealing-furnaces generally.

I will now proceed to describe my invention, so that others skilled in the art to which it appertains may apply the same.

In the drawing, A indicates the main walls of a furnace, whose general shape will conform to the number, size, and relative arrangement of the annealing-retorts to be inclosed.

Where the retorts are large, as for annealing sheet-iron, or a series of retorts are employed for annealing different articles, more than one combustion-chamber may be used to insure uniform heating of all the retorts, and they are preferably located at one end of the furnace, as shown at *a a'*. The grate (or grates) therefor is composed of a series of bars, *b*, which should be sufficiently long to project beyond the main wall A of the furnace, are journaled in the frame *b'*, so as to be capable of revolving like shafts, and are notched or serrated on their projecting ends to engage with a transverse worm-shaft, *b''*, also journaled in or on the frame *b'*. This worm-shaft serves to revolve the grate-bars, and impart to

them a motion which, while causing the discharge of fine ash, &c., is not sufficiently violent to materially disarrange the superincumbent body of coals. In order that clinkers, or like refuse, which might accumulate on the grate or adhere to the bars thereof may be readily removed, one portion of the frame b^1 , preferably that wherein the projecting ends of the revolving bars are journaled, is hinged or pivoted, as at b^2 , and is controlled by a link and lever, b^4 , whereby the grate can be lowered at one end or inclined, to permit the introduction of a poker or suitable tool and the removal of refuse.

D represents the inclined chute or feed-opening for supplying the combustion-chamber a , located in the wall A at a suitable distance above the grate-bars, and at a point opposite the face of the fire-bridge, so that the latter shall serve to deflect the coal and insure its proper piling before the bridge.

E represents the fire-bridge, which is formed hollow and perforated, as at ee , along its face, to deliver air against the pile of fuel in the combustion-chamber a , under the throat a^3 , in a direction contrary to the draft from the ash-pit and the course of the products of combustion. This insures perfect combustion in chamber a , and prevents the draft from carrying much fine ash, &c., into the tortuous flues which surround the annealing-retorts. It also serves to counteract the effects of a rush of cold air over the fuel and into the flues when the feeding-chute D is opened. The fire-bridge E rises to a point near the arch of the fire-chamber, so as to form a narrow throat, a^3 . The space back of the bridge E is divided by a horizontal or arch wall, E^1 , into a flue, a^4 , for the passage of the products of combustion on their way to envelop the retort or retorts, and an induction flue or passage, E^2 , for the air which supplies the bridge.

Above the horizontal arch or wall E^1 , and in the flue a^4 , is erected a second bridge or cross wall, a^5 , which serves to arrest any fine dust or ash which may be carried over fire-bridge E, and also converts a portion of the flue a^4 into a trap or dust-chamber. In order to clean out this chamber a door or man-hole (indicated in dotted line, Fig. 1) may be made in the furnace-wall. The space E^2 below the horizontal wall or arch E^1 is converted by longitudinal partial divisions into a tortuous passage, which, receiving air through a port, e^1 , in the end wall of the furnace, conducts it back and forth beneath the flue a^4 until it is thoroughly heated, and then delivers it through a port to the hollow fire-bridge E.

The flue a^4 , leading from the combustion-chamber along the bottom of the retort, communicates at the far end by two or more ports, c e , with tortuous flues C on the two sides of the retort C', the retort in the present instance being represented as a long retort, extending from end wall to end wall, and adapted to the annealing of sheet metal, sheet-iron, &c. The side flues, C, extend from end to end of the re-

tort, and are rendered tortuous, to retard the passage of the products of combustion, by alternate vertical rising and pendant walls c^2 c^3 , which project partially across the flue. At the front end of the retort (or that part over the combustion-chamber) the flue C communicates by ports f with a tortuous flue, F, formed by cross-walls f^1 , having ports f^2 at alternate sides, and the flue F in its turn communicates by ports g with an unobstructed flue, G, which leads directly to the stack.

By following the course of the flues just described, it will be seen the products of combustion pass first from front to rear under the retort; thence back to the front or toward the combustion-chamber along the two sides of the retort; next from front to rear over the top of the retort, and thence into the smoke-stack, or back above the retort, so that the retort is uniformly heated, and is protected against the direct action of the flame, and against sudden cold drafts.

In an annealing-retort for plate metal, sheet-iron, and like articles, I prefer to form a track composed of concave-faced rails r for the reception of anti-friction balls or bearings r^1 , and employ therewith a truck, having longitudinal grooves r^2 to rest on the balls r^1 , as shown. R indicates the truck; R^1 , packs of sheet-iron arranged thereon; and R^2 , a slab, weighting the sheet iron and retaining it in position. In order to insert and withdraw the trucks from the retort, elevated tracks S may be provided. B indicates the door of the retort, which should have a proper groove in its inside for clay, wherewith to lute the opening, and a mica or similar closed peep-hole for the inspection of the charge.

In order that the door, which is large and heavy, may be properly handled, I support and control it by a link or chain having an anti-friction roller, which traverses on a curved telegraph or curved elevated rail, B^1 , secured to the top of furnace-wall A. By this means the door can be handled when hot without materially injuring the luting. b^5 is a pipe, tube, or similar opening in the door of the furnace, for the introduction of agents employed in the treatment of the metal during the annealing process.

In Figs. 4 and 5 are shown the manner of setting smaller retorts, such as are employed for nails and like small articles, and the arrangement of cleaning hearth for burning the grease from horseshoes and like articles. Though situated within the walls A of the annealing-furnace, and capable of being heated from the main combustion-chamber by extending the flues of the main retort C', or cutting a port at any convenient point in the cross-walls, yet in order to heat the retorts uniformly, and also in order that one series of retorts may, if desired, be used independently of the other, I prefer to employ a supplemental combustion-chamber, a^1 , with appropriate grate. From one side of said chamber a^1 a throat or flue, i , rises vertically, delivering the flame and

products of combustion over a fire-bridge, *j*, (which may be hollow, perforated, &c., as before specified) onto an inclined hearth, *I*, formed by enlarging the flue above the arch. This inclined hearth is provided at each end with a door or port, through which horseshoes and like articles may be introduced and withdrawn, and should also be provided with sides guides *n*, to limit and direct the travel of any articles over the hearth. The products of combustion escape from the hearth into smaller flues *m o*, and thence across the sides and top of first the lower and afterward the upper retorts along a series of tortuous channels formed by alternate vertically-rising and pendent walls, in substantially the manner before set forth in the description of retort *C'* and its flues.

The operation of my annealing-furnace, and the manner I prefer to conduct the annealing process therein, are as follows: The several retorts having been charged with the article or articles to be annealed, and a fire built in one or both of the combustion-chambers, as circumstances require, the fuel on the grate-bars *b* can be replenished from time to time, as indicated, through chute *D*. The fresh coal, on its entrance into the combustion-chamber, will be deflected by the bridge-wall and roll back therefrom, heaping near the center of the chamber. Air entering port *e'* will traverse tortuous passages *E*², and after being fully heated will enter the hollow fire-bridge *E* through port *e*², and escape through ports *e* thereof into the combustion-chamber across the path of the outgoing products of combustion. This arrangement insures, first, protection to the bridge-wall; secondly, thorough combustion; and, thirdly, reduces the amount of fine ash or dust carried over the fire-bridge *E*. When the grate is to be freed of ashes the worm *b*² is turned, causing the bars *b* to revolve, displacing the ashes without materially disturbing the fire.

To remove clinkers, the bars are dropped at one end by means of pivoted frame *b*³ and lever *b*⁴, and a suitable tool introduced.

The products of combustion, on their way to retort-flues, pass first through flue *a*⁴, where bridge *a*⁵ forms an eddy, causing the deposit of any fine dust, &c., carried over the fire-bridge *E*. Thence through ports *c c* the products of combustion enter the flues *C* in the sides of the retort, pass forward, and rise through ports *f* to flue *F*, taking a zigzag course to the opposite end of the retort, and into flue *G*, which connects directly with the stack, thus enveloping and repeatedly traversing the length of the retort, so as to insure perfect and uniform heating.

The products of combustion from combustion-chamber *a*¹ rise at one side through flue *i*, and are deflected over bridge-wall *j* onto the horseshoes or other articles lying on hearth *I*, burning therefrom oil or surplus fatty matters. Thence the products of combustion pass by flues *m o* to the two sides of the first retort, which they traverse, as before specified, after

which they envelop the second or upper retort, and so on to any number of a series.

Among other advantages of my invention are, first, that the construction of the grate and its connections enables me to keep a steady, uniform fire; secondly, the arrangement and construction of the fire-bridge, combustion-flue, &c., enables me to prevent the entrance of dust and dirt into the retort-flues, so that tortuous flues can be used without liability of clogging or choking; and, thirdly, the arrangement and construction of the retort-flues keep the products of combustion for a long time in contact with the retort, insuring the even heating thereof.

Having thus described my invention, what I claim, and desire to secure by Letters Patent, is—

1. The combination, with the combustion-chamber, of the journaled bars, set in a suitable frame, and the worm-shaft for revolving the bars, substantially as specified.

2. The combination of the revolving bars and the frame having the pivoted section, wherein the bars are journaled at one end, substantially as and for the purpose specified.

3. In an annealing furnace having a retort inclosed by tortuous flues, the combustion-chamber having a suitable grate, in combination with the hollow perforated fire-bridge and the feed-chute, the feed-chute being arranged opposite the face of the fire-bridge, substantially as and for the purpose specified.

4. The combination, with the annealing-retort, inclosed by tortuous flues, of the combustion-chamber and its grate, the hollow perforated fire-bridge, the air-induction flue, and flue of the combustion-chamber, provided with the supplemental bridge or cross-wall, forming the dust-chamber, the whole arranged substantially as and for the purpose specified.

5. The combination, with the retort of an annealing-furnace, of a series of tortuous flues, *C*, formed by pendent walls *c*³, and verticals *e*² and *F*, formed by cross-walls *f*¹, said flues extending longitudinally and transversely of the retort and connected by ports, whereby the products of combustion are caused to traverse back and forth and envelop the retort, substantially as and for the purpose specified.

6. The combination, with the combustion-flue of an annealing furnace, of an inclined hearth, interposed between the combustion-chamber and annealing retort or retorts, substantially as and for the purpose specified.

7. The combination, with the retort-door of an annealing-furnace, of a telegraph or curved elevated rail, *B*¹, secured to said furnace, and a suspension-link, substantially as and for the purpose specified.

In testimony whereof I, the said WILLIAM S. MCKENNA, have hereunto set my hand.

WILLIAM S. MCKENNA.

Witnesses:

JOHN K. SMITH,
C. E. MILLIKEN.