

J. ALLONAS.
Grain-Separators.

No. 209,208.

Patented Oct. 22, 1878.

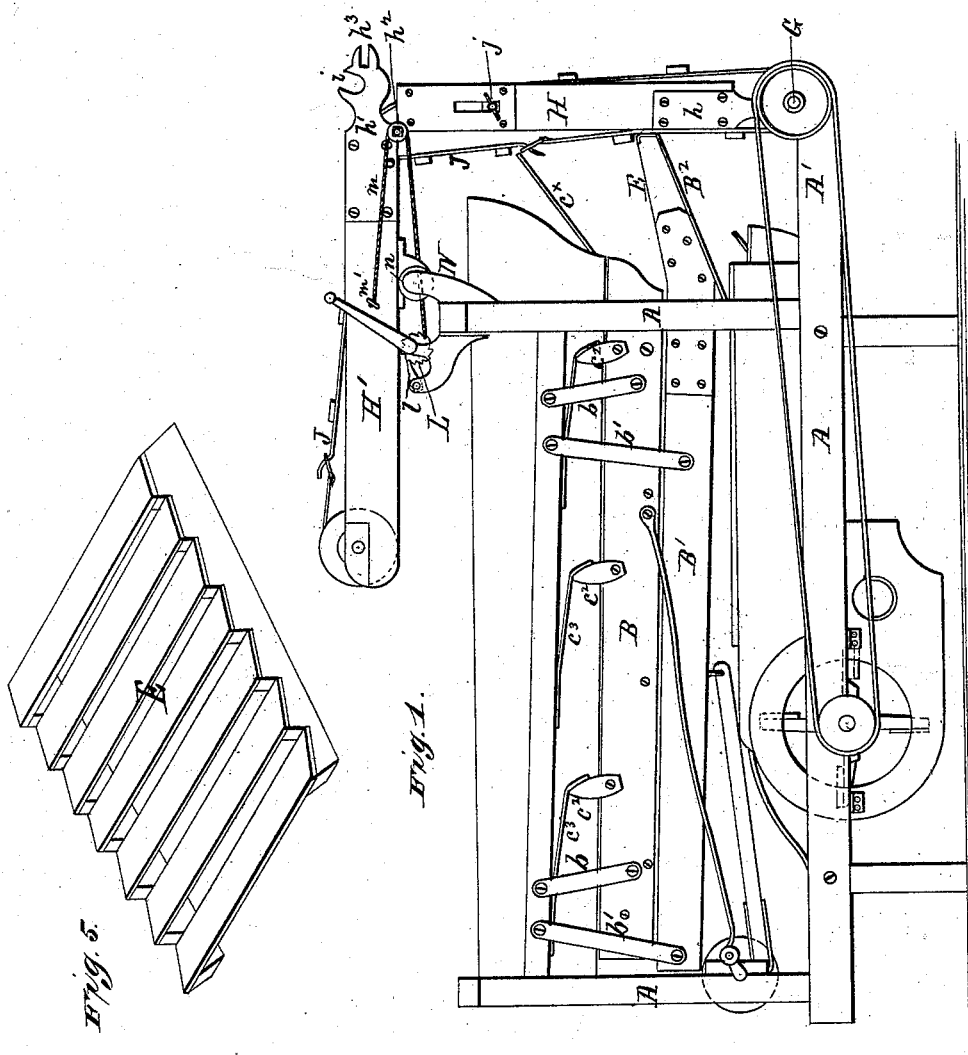

WITNESSES
Alexander Mahon
John G. Coontz

BY
Joseph Allonas
 by *Chas. Smith*
 ATTORNEY

J. ALLONAS.
Grain-Separators.

Patented Oct. 22, 1878.

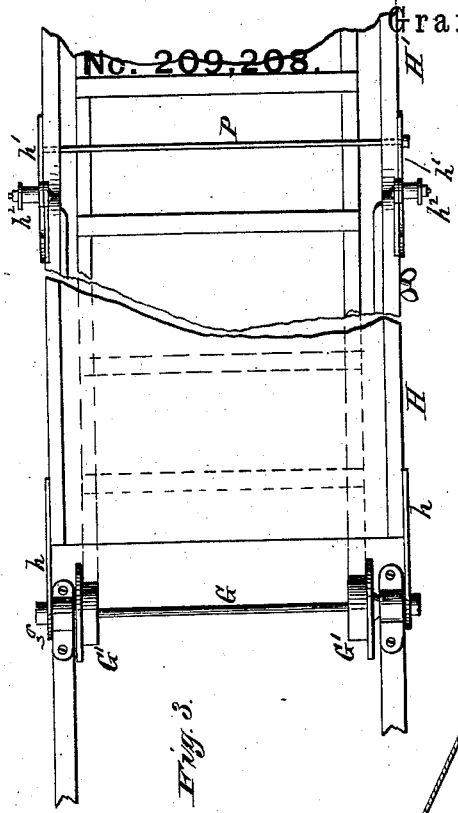

Fig. 3.

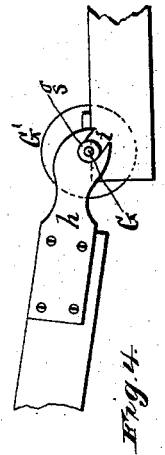

Fig. 4.

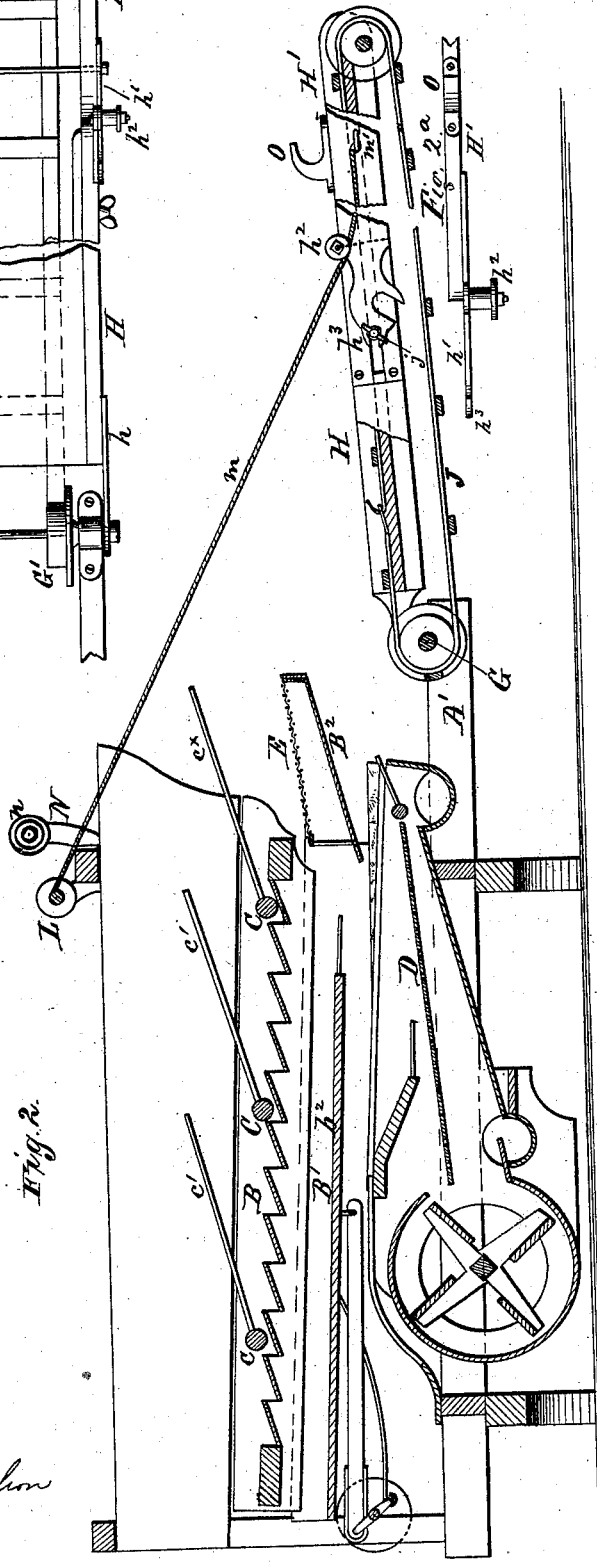

Fig. 2.

WITNESSES
Alexander Nelson
John B. Costa

INVENTOR
J. Allonas
 by *Edell Smith*
 ATTORNEY.

UNITED STATES PATENT OFFICE.

JOSEPH ALLONAS, OF MANSFIELD, OHIO.

IMPROVEMENT IN GRAIN-SEPARATORS.

Specification forming part of Letters Patent No. **209,208**, dated October 22, 1878; application filed July 18, 1878.

To all whom it may concern:

Be it known that I, JOSEPH ALLONAS, of Mansfield, county of Richland, State of Ohio, have invented certain new and useful Improvements in Grain Separator and Stacker Attachment to Thrashing-Machines, of which the following is a full, clear, and exact description, reference being had to the accompanying drawings, making part of this specification, in which—

Figure 1 is a side elevation of my improved separator and stacker with the latter folded for transportation. Fig. 2 is a vertical longitudinal section through the same, with the stacker, partly in section, arranged in working position. Fig. 2^a shows one of the joints between the sections of the stacker. Fig. 3 is a plan view of the joint or hinge between the separator and stacker. Fig. 4 is a side elevation of the same; and Fig. 5 is a perspective view of the extension-piece to the lower shaker, provided with "stepped" slats in lieu of the wire screen shown in Fig. 2.

Similar letters of reference denote corresponding parts wherever used.

My invention consists, first, in providing the lower separating-shaker with a removable tail-extension, provided with a separating surface or screen, composed either of wire or a series of inclined slats, arranged in steps, as the kind of grain or the condition of the tailings operated upon may require, for effecting the thorough separation of the grain.

It further consists in a novel construction of the hinge or joint between the stacker and the separator-frame, adapting the former to be readily removed, and enabling me to use either the whole of the jointed stacker or a single section (the outer one, or that farthest from the machine) only, as the height at which the straw is to be deposited may require.

The invention further relates to the manner of folding the stacker over upon the machine for transportation, &c., and to the means for locking the same in its folded position, all as hereinafter fully explained.

In the accompanying drawings, A represents the frame of the separator, made in any usual or preferred form adapting it to the work required of it. B is the upper shaker or straw carrier and separator, and B¹ the lower shaker, both being suspended within the frame A upon

links *b b b¹ b¹*, in such manner as to adapt them to be simultaneously vibrated in opposite directions longitudinally. The upper shaker or straw-carrier, B, is provided with a screening-surface, composed, preferably, of a series of inclined stepped slats, adapting the grain and chaff to escape between them to the lower shaker while bearing the straw onward to the discharging end. Any usual form of screening-surface may, however, be employed in lieu of the slats, if desired. In addition to this slatted separating-surface, the shaker B is provided with a series of transverse rock-shafts, C, arranged above the slats, and having their bearings in the side frame-bars of the shaker B. The shafts are armed each with a series of lifting-fingers, *c¹*, and are provided at their ends with crank-arms *c²*, connected by straps *c³* with the frame A, in such manner that as the shaker B is vibrated a rising-and-falling movement of the fingers is produced for tossing or agitating the straw and effecting the separation of the grain therefrom.

The grain and chaff, as they are liberated from the straw, escape between the slats of shaker B, and fall upon the flooring *b²* of the lower shaker, B¹, and are carried forward thereby and deposited upon a screen, D, where they are subjected to the blast from the fan for removing the chaff, in the usual manner. The tail end of this lower shaker is extended beyond the end of the frame A, and is provided with an inclined return chute-board, B², for catching and returning to the action of the screens any grain that may be carried over the tail end of the upper shaker or carrier, B.

Over this inclined flooring B² is placed a removable screen or separator, E, having a separating-surface composed either of an open wire screen, as shown in Fig. 2, or of a series of inclined stepped slats, as shown in Fig. 5. This separating-surface is applied to a frame fitting within the extended tail end B² of the lower shaker, B¹, adapting it to be readily removed and substituted by another and different separating-surface, as the character or condition of the grain operated upon may require. This portion E of the lower shaker it will be seen is extended beyond the upper shaker, B, and would receive both the straw and grain escaping therefrom, but that the lifting-fingers *c¹* of the final rock-shaft C overhang said exten-

sion, and serve to uphold, agitate, and bear the straw onward, while permitting the ready escape of any grain that may have passed over the tail end of the upper shaker. The grain thus escaping is caught by the extension E, separated from the straw and chaff thereby, and is returned by the chute-board B² to the action of the screen or screens D.

The lower longitudinal frame-timbers are extended beyond the rest of the frame A at A', and are provided with suitable bearings for the transverse stacker-shaft G, which has upon one of its ends a pulley or band-wheel, through which motion is imparted to it from any convenient driving-shaft. The shaft G is provided with pulleys or band-wheels G' G', for driving the stacker-web or endless rake. The stacker-frame H is composed of longitudinal side bars, united by a flooring, around which the endless slatted apron or rake passes for removing the straw. The side bars are provided with straps *h* *h*¹, having forked ends, the fork being made in the form of an inverted U-shaped slot or notch, *i*, arranged obliquely to the plane of the stacker, and fitting upon the bearing-sleeves *g* of the shaft G, as shown in Figs. 3 and 4. It will be seen that by this construction, while the straps *h* will be held firmly in place when the stacker is in operation by the endless web or bands J of the stacker-rake, the stacker may be readily removed when desired by simply lifting the forked straps out of engagement with the shaft G or its bearing-sleeves *g*. The stacker is composed of two or more sections, H H', hinged or jointed together, as shown at *h*², in such manner as to permit it to be folded for packing or transportation, while at the same time giving the desired length for elevating and stacking the straw to any desired height; and each section is provided with the forked straps *h* or *h*¹, as shown, so that they may not only be readily united to each other, but, also so that either section may be coupled directly to the shaft G, as explained, thus facilitating the shortening or lengthening of the stacker by the removal or addition of one or more sections, as required. The straps *h*¹, intermediate between the sections H H', are provided not only with the bearing slot or notch *i*, but with lugs or ears *h*², through which the sections are hinged one to the other, and also with slotted arms *h*³, through which, by means of an adjustable thumb-nut, *j*, the joint between the sections may be locked or made rigid when the stacker is in its extended or working position. (See Fig. 2.)

The stacker is adjusted and held at any desired angle of inclination by means of cords *m*, connecting it with a windlass, L, on the separator-frame, as shown. These cords are arranged at the sides of the stacker-frame, and are attached to the outer section, H', at *m*¹, passing thence forward under friction-rollers on the pin or pivot of the hinge at *h*² between the sections, said pivots being projected to receive said rollers, as shown in Fig. 2^a.

The frame A has standards N secured upon it, provided with flanged friction-rollers *n*, and the outer section, H', of the folding stacker (see Fig. 2) has hooked brackets *o*, applied to the upper face of its side bars, as shown, the arrangement being such that when the stacker is folding down upon the flanged rollers for transportation, as shown in Fig. 1, the hooks are drawn under said rollers by the action of the windlass and cords, and serve effectually to lock the stacker in its folded position, pawls *l* locking the windlass and preventing the hooks O from being withdrawn. By this arrangement the stacker is not only folded upon the machine out of the way, but it is firmly secured in place, and any strain upon or injury thereto consequent upon the jarring of the machine in the process of transportation is effectually prevented.

When the stacker is to be folded, a rod or rods, P, is passed through its side frame-bars at or near the joints above the web or endless rake-bands, for causing the latter to fold up compactly with the sections, thus obviating the necessity for removing the web or rake. This rod is placed under the web when the latter is in use.

Having now described my invention, what I claim as new, and desire to secure by Letters Patent, is—

1. The combination, with the straw-carrier, of the reversely-vibrating lower shaker, B¹, provided with the removable tail-extension screen or separator E, having the return chute-board, substantially as and for the purpose set forth.
2. The outer section, H', of the stacker, provided with the forked or notched side bars or plates *h*¹, having the perforated lugs or ears *h*², adapting it to be applied either directly to the stacker-shaft or to be hinged to the section H, as described.
3. The jointed straw elevator or stacker, adapted to be folded against the end of and over upon the separator-frame, in combination with the windlass, cords, and hooks, for adjusting and holding said stacker, as described.
4. The jointed folding stacker, in combination with the endless stacker web or rake and the removable rod P, adapting the web or rake to be folded with the stacker, substantially as described.
5. The outer folding section, H', of the stacker, provided with the hooks O, in combination with the retaining spurs or rollers *n* on the main frame, for locking the stacker in its folded position, substantially as described.
6. The combination, with the folding stacker, of the cords and windlass for adjusting and holding it, and the retaining-hooks O and friction-rollers *n*, for locking the stacker in its folded position, substantially as described.

JOSEPH ALLONAS.

Witnesses:

A. J. TWITCHELL,
D. S. HOOVER.