

C. F. ASIRE.  
Lifting-Jack.

No. 209,211.

Patented Oct. 22, 1878.

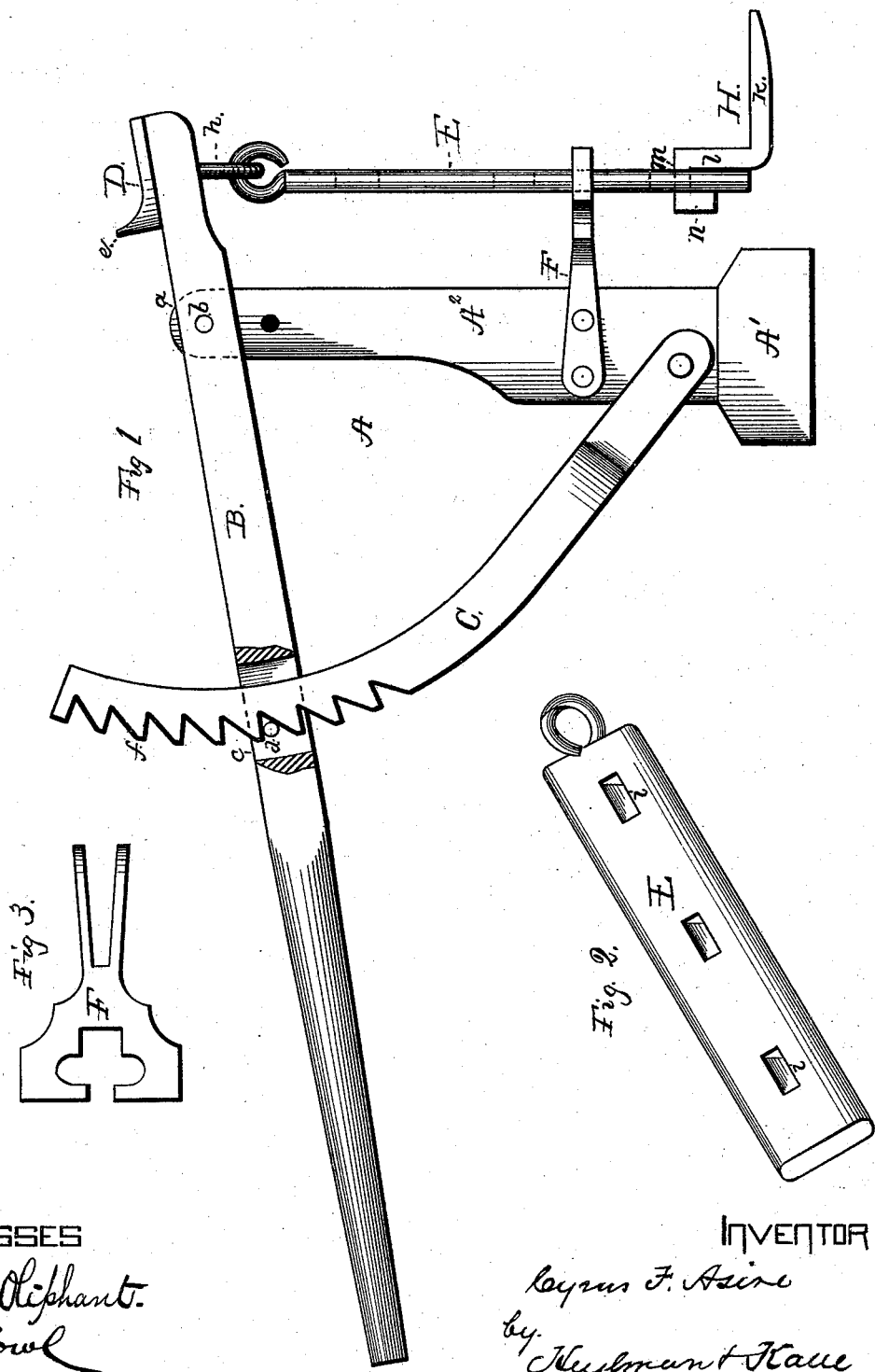

WITNESSES  
*Nat. E. Oliphant.*  
*D. P. Cowl*

INVENTOR  
*Cyrus F. Asire*  
 by *Weyman & Howe*  
*Atty's*

# UNITED STATES PATENT OFFICE.

CYRUS F. ASIRE, OF SALTILLO, OHIO.

## IMPROVEMENT IN LIFTING-JACKS.

Specification forming part of Letters Patent No. **209,211**, dated October 22, 1878; application filed September 30, 1878.

*To all whom it may concern:*

Be it known that I, CYRUS F. ASIRE, of Saltillo, in the county of Holmes and State of Ohio, have invented a new and valuable Improvement in Hoisting-Jacks; and I do hereby declare that the following is a full, clear, and exact description of the construction and operation of the same, reference being had to the annexed drawings, making a part of this specification, and to the letters and figures of reference marked thereon.

Figure 1 of the drawings is a representation of a side view of the hoisting-jack. Fig. 2 is a perspective view of the lifting-bar. Fig. 3 is a plan view of the guide.

The object of my invention is to construct a hoisting-jack by which heavy weights may be lifted either from the ground or top of the jack; and the improvements consist in the novel means, as will be hereinafter more fully set forth, and pointed out in the claims.

In the accompanying drawings, which form a part of this specification, the letter A represents a substantial frame, composed of the base-piece A<sup>1</sup> and the standard A<sup>2</sup>, to which the operative parts are secured. B is the operating-lever, formed with a mortise, *a*, which is passed over the upper end of the standard A<sup>2</sup>, and attached thereto by means of a bolt or pivot, *b*. This lever is also provided about midway of its length with another mortise, *c*, within which is arranged a transverse pin, *d*, and through which the curved rack-bar C passes. The forward end of this lever is provided with a cap-plate, D, suitably attached thereto by means of drive-nails, screws, or bolts. The upper surface of this plate is curved, forming a seat for the object, terminating at its rear end in the raised portion *e*, serving the purpose of a stop, which keeps the raised object from sliding downwardly.

The curved bar C is pivoted to the lower end of the standard A<sup>2</sup>, and is provided at its upper under surface with a series of ratchet-teeth, *f*, by which it is caused to engage with the transverse pin in the lever and retain the same in any desired position. This curved bar C should be so arranged and pivoted to the standard that the upper portion will

slightly more than balance, and thereby at all times engage with the pin *d* in the mortise *c* of the pivoted lever.

To the under side of the forward end of the operating-lever is secured a link or staple, *h*, to which is fastened a lifting-bar, E, capable of a vertical movement in guides F of the construction substantially as shown in Fig. 3. This lifting-bar is provided with a series of oblong slots, *i*, to receive the detachable foot-piece H. This foot-piece H is composed of the horizontal bar *k*, adapted to be placed under a load to be raised, and the vertical bar *l*, horizontal bar *m*, and short vertical bar *n*, forming a hook, so as to pass through a slot and embrace the lifting-bar, substantially as shown in Fig. 1 of the drawings.

The vertical bar *n* of the foot-piece should be of a length shorter than the length of the oblong slots *i* in lifting-bar, so that it can be applied and adjusted readily in the slots.

The hook portion of the foot-pieces rests in one or other of the series of notches *i* formed in the lifting-bar, the object of the series of notches being to allow of the adjustment of the foot-piece to different heights to suit objects to be raised. Of course, the foot-piece can be made of a single piece of metal, cast or wrought iron, bent to the shape substantially as shown.

To raise a wheel above the ground, in order that it may be removed from the spindle for greasing or repairing, the handle of the lever is depressed, the end with cap-plate D having been placed under the axle. By pressing down the handle of the lever, the rack-bar is made to engage with the pin *d* automatically and lock, and the object raised. If the object is near the surface of the ground, or a fence to be raised, the lifting-bar E is employed in raising, the foot-piece H being properly adjusted in the slots of the lifting-bar and placed under the object.

What I claim as my invention, and desire to secure by Letters Patent, is—

1. The combination, with a lifting-jack, of a lifting-bar, E, having a series of slots, *i*, and an adjustable foot-piece, H, suitably connected with the jack.

2. The combination, with a jack of the construction substantially as described, of the slotted lifting-bar, connected at its upper end to the forward end of the operating-lever by means of the link-connection, and guided in its vertical movement by the guide F, and of the adjustable foot-piece H, as described.

In testimony whereof I have hereunto subscribed my name.

CYRUS FRANKLIN ASIRE.

Witnesses:

ROBERT JUSTICE,  
J. E. ALBERTSON.