

J. E. BOTT.
Injector.

No. 209,220.

Patented Oct. 22, 1878.

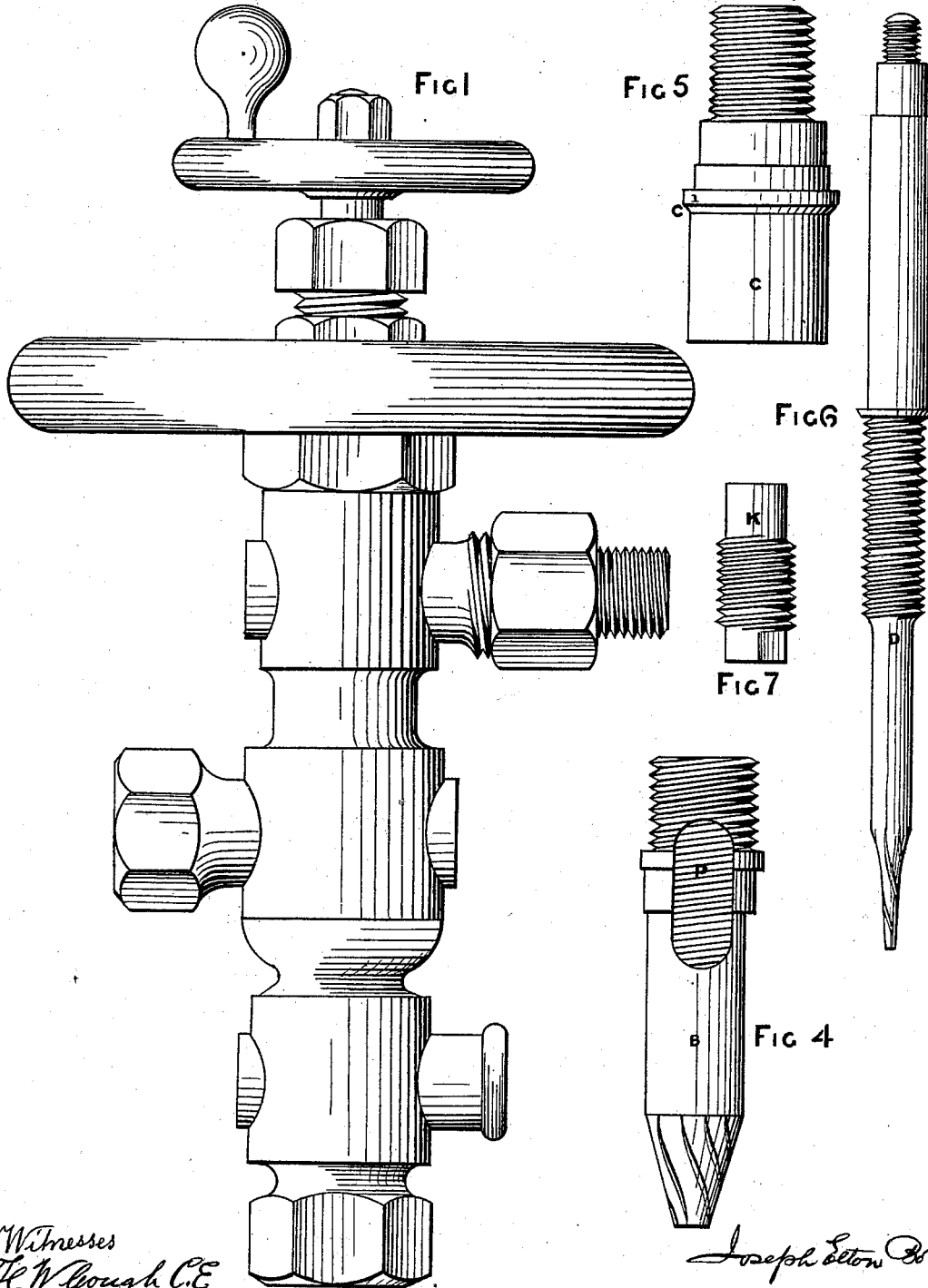

Witnesses
L. W. Gough C.E.
J. H. Gough.

Joseph Elton Bott
Inventor.

J. E. BOTT.
Injector.

No. 209,220.

Patented Oct. 22, 1878.

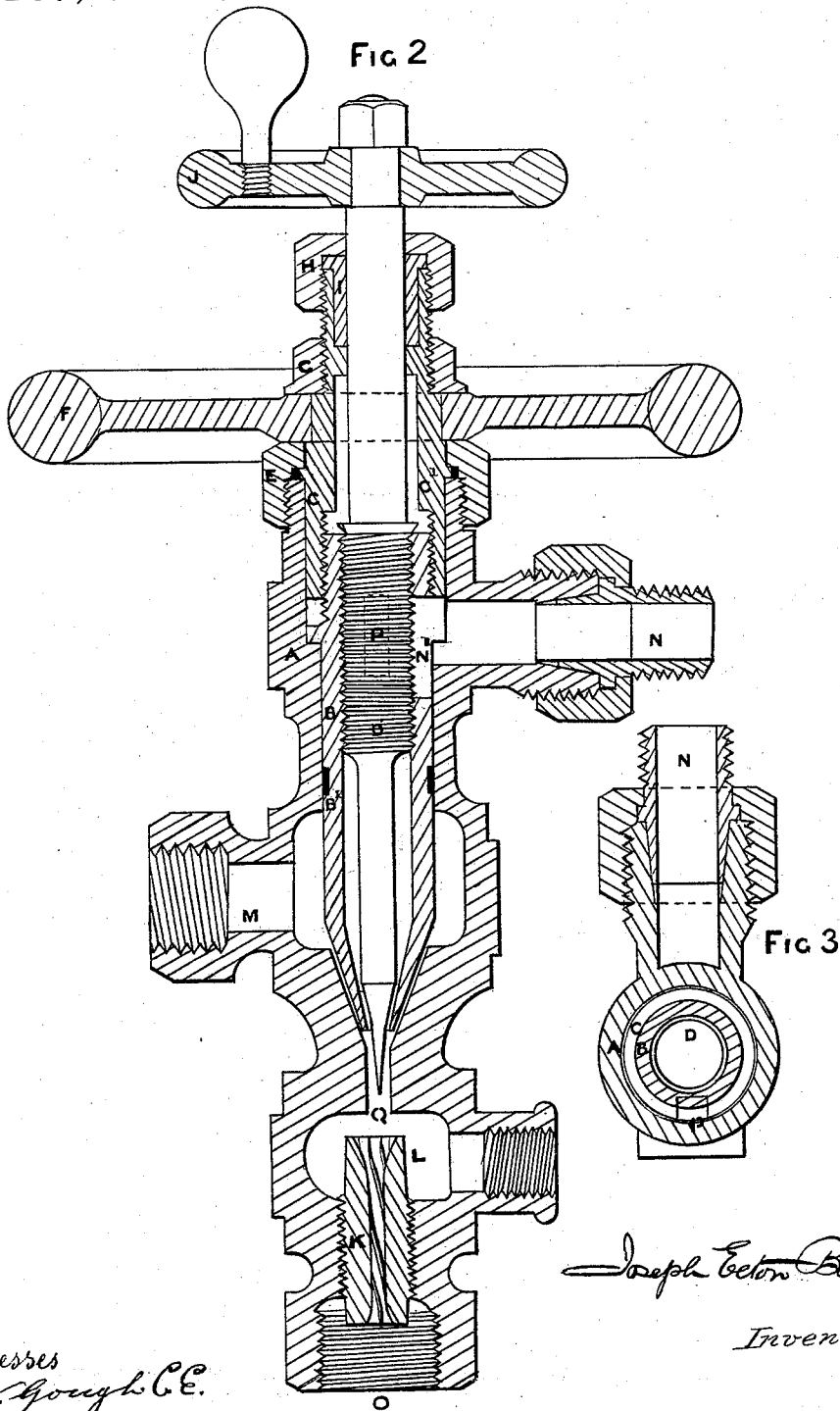

Joseph Eaton Bott
Inventor.

Witnesses
J. W. Gough C.E.
J. H. Gough.

J. E. BOTT.
Injector.

No. 209,220.

Patented Oct. 22, 1878.

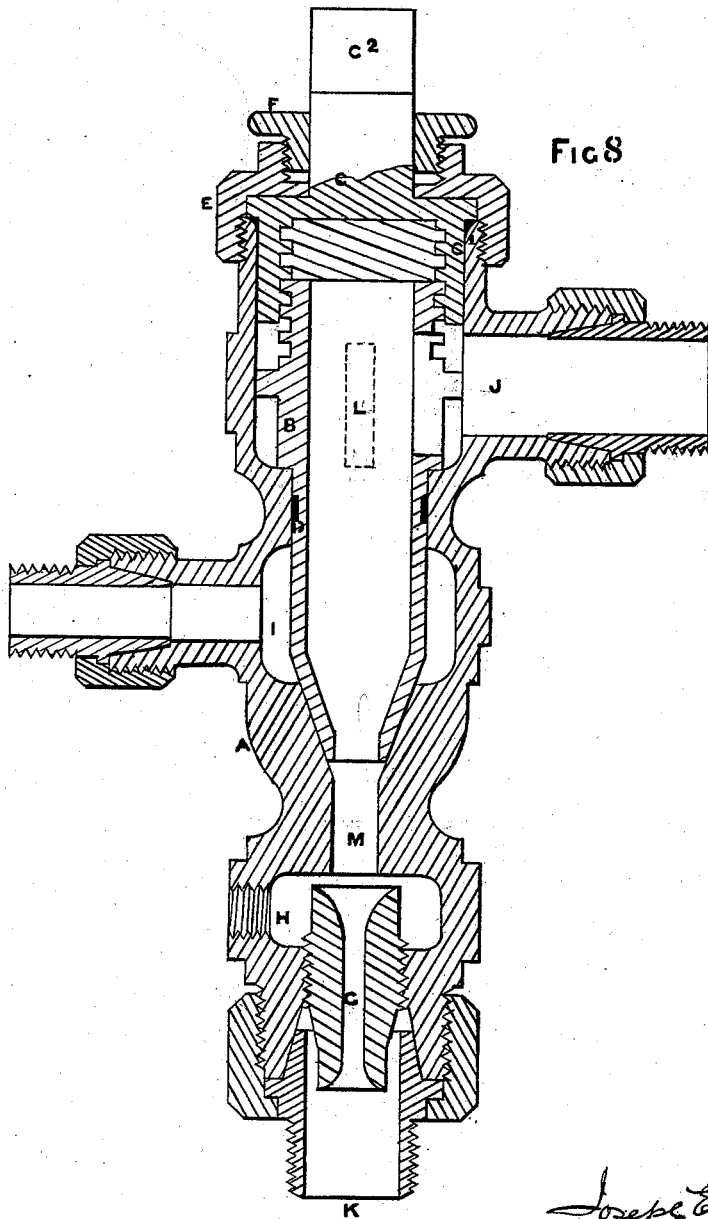

Fig 8

Witnesses
H. W. Gough C.E.
J. H. Gough.

Joseph Eaton Bott

Inventor:

J. E. BOTT.
Injector.

No. 209,220.

Patented Oct. 22, 1878.

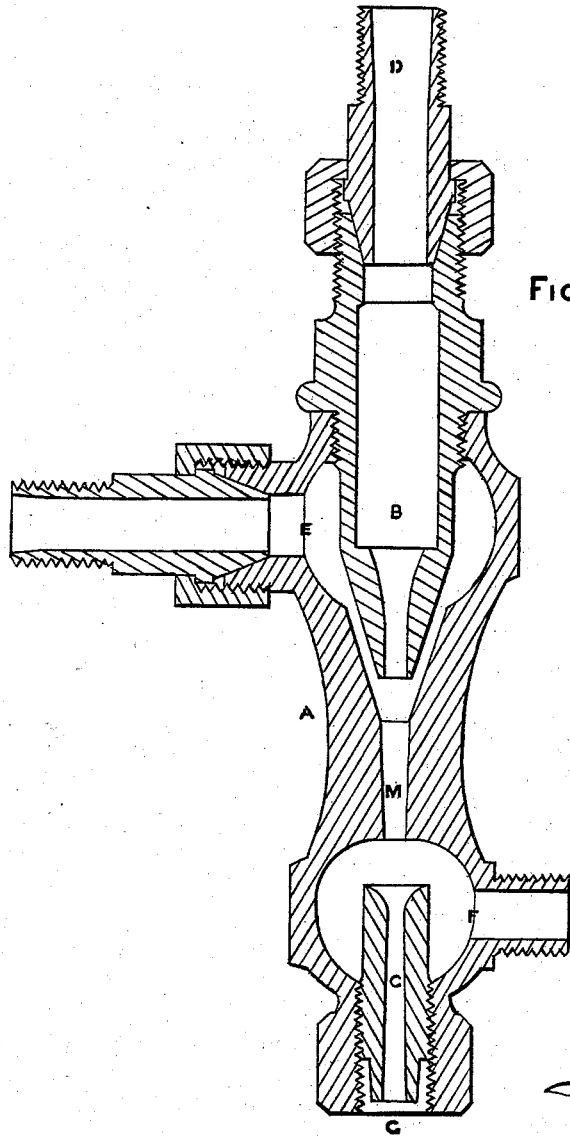

FIG 9

Joseph Walton Bott

Inventor.

Witnesses.
H. W. Gough C.E.
J. H. Gough.

UNITED STATES PATENT OFFICE.

JOSEPH E. BOTT, OF NOTTINGHAM, ENGLAND, ASSIGNOR TO CHARLES
ODLING, OF SAME PLACE.

IMPROVEMENT IN INJECTORS.

Specification forming part of Letters Patent No. 209,220, dated October 22, 1878; application filed
July 5, 1878.

To all whom it may concern:

Be it known that I, JOSEPH ELTON BOTT, of Nottingham, England, have invented new and useful Improvements in Injectors, of which the following is a specification, reference being had to the accompanying drawing.

I employ three modifications of injectors. The first modification consists of an injector constructed to pump or lift its supply of water; the second is an injector that forces its supply of water when on a level with or above the injector; and the third modification consists of a non-regulating injector.

Referring to the drawings, Figure 1 is an outer view of No. 1 injector; Fig. 2, a longitudinal sectional view; Fig. 3, a cross-section on the line R R of Fig. 2. Figs. 4, 5, 6, and 7 are parts of the same, shown separately. Fig. 8 is a sectional view of a forcing-injector, and Fig. 9 a sectional view of a non-regulating injector.

In cases where an injector is required to first pump or lift its supply of water, I construct an injector of the following parts, (shown at Figs. 1 to 7:)

A is the body of the injector; B, a movable nozzle, through which steam is passed. This nozzle is provided on its exterior with spiral grooves, for a purpose which will be hereinafter explained. B', packing to make the same steam-tight; C, an internally screw-threaded cap to raise and lower the steam-nozzle; C', a conical seat to prevent leakage; D, a spindle arranged centrally within the nozzle B, and having its tapering surface *b* provided with spiral grooves, terminating at its point; E, a securing-nut; F, hand-wheel for working the regulating-cap C; G, a securing-nut; H, gland-nut; I, gland; J, a wheel for operating the spindle D, a portion of the body of which is screw-threaded, to engage with an internal screw-thread in the upper portion of the nozzle; K, an internally spiral-threaded nipple or injection-cone, for increasing the speed of feed; L, air-chamber and overflow for waste-water; M, suction-pipe from water-supply; N, steam-pipe from boiler; N', opening in the movable nozzle B to admit steam; O, delivery of feed-water to boiler; P, solid guide working in a slot cut in the movable nozzle B, (shown by dotted lines in Fig. 2;) Q, an improved

straight bore of reception-orifice below the nozzle B.

The corresponding parts in Fig. 3 are indicated by like letters of reference.

The action of this lifting and forcing injector is as follows: The hand-wheel F is turned until the nozzle B is raised to its full height. During this action the spindle D is retained on its seat by being screwed into the nozzle B independent of any other part. The nozzle B does not revolve, but is raised and lowered by means of the rotation of the screw-cap C, and prevented from rotating by means of a slot cut in it, which works upon a solid guide-block, P, cast with the body A. The raising of the spindle D above the lower edge of the opening N' admits steam into the nozzle B, the point of the spindle causing the steam to form an annular spiral ring, which creates a vacuum in the water-pipe connected to the injector at M, the steam being immediately condensed by the rush of water which follows and fills the vacuum. The grooved external surface of the nozzle B also causes the water to form another spiral annular ring, moving in the same direction as the spiral steam-jet. The two, combining, form a very powerful spiral jet, which sucks air through the air-chamber L, which air becomes rarefied by the heat imparted to it, and gives additional impetus to the spiral jet, which is increased in pressure by means of the reduced bore of the regulated injection-cone K.

According to the high or low pressure of steam used, a corresponding quantity of uncondensed steam or surplus water will be ejected through the overflow, which may be regulated by the double action of the steam-nozzle B, which either reduces the steam and increases the water, or increases the steam and reduces the water, thus effectually preventing the water from flooding the steam, or the steam from overpowering the water, as is the case in many other kinds of injectors. The water, steam, and air, after having passed the injection-cone K, are forced into the boiler through a pipe connected to the injector at O, the water entering the boiler at a temperature of from 180° to 208°, Fahrenheit's thermometer, according to the pressure of steam.

A second modification of an injector is

shown in section at Fig. 8, for forcing the water when the supply is on a level with or above the injector, as in case of locomotives or land and marine boilers, and consists of the following parts: A, the body of the injector; B, movable externally spiral-grooved nozzle, through which steam is passed; C, a screwed cap to raise or lower the nozzle; C¹, conical seat to prevent leakage; C², solid square for a lever to work the cap; D, packing; E, gland-nut, F, gland; G, screwed injection-cone, formed square at the bottom to facilitate examining and cleaning by withdrawing the cone; H, air-chamber and overflow; I, water inlet and chamber; J, steam inlet and chamber; K, delivery to boiler; L and L¹, slot and stud to give motion to the nozzle B; M, straight bore of reception-orifice. By an injector constructed as above described the quantity of water can be regulated, so as to prevent the water flooding the steam, or the steam overpowering the water. When the steam-pressure varies more than ten pounds either above or below the general working pressure, this injector will deliver water into the boiler at from 180° to 205°, Fahrenheit's thermometer, according to the steam-pressure and temperature of the supply-water.

In cases where the water-supply is on a level with or above the injector, and the steam-pressure of the boiler to which it is attached does not vary more than ten pounds' pressure above or below the general working pressure, I employ a third modification of injector, which I call a "non-regulating injector," consisting of the following parts, (shown in section at Fig. 9:) A, body of the injector; B, a fixed externally spiral-threaded nozzle, through which steam is passed; C, screwed injection-cone, formed square at the bottom; D, inlet for steam from the steam-pipe to which it is connected; E, water inlet and chamber; F, air-chamber and overflow; G, delivery to boiler.

The action of the above-described injector is as follows: Steam is admitted direct to the tapered nozzle B, and upon the water being admitted through E, the steam is instantly condensed, and the combined steam and water takes the form of a spiral jet, which gathering air from the air-chamber F, its power is increased, and it enters the boiler through the usual back-pressure valve. The nozzle B, being set at the time of making, requires no further attention in this injector. There is only a slight overflow for a moment, until the jet of steam is fully combined with the water. If the water and steam cocks are connected to one lever they may be opened simultaneously, and there will not be any overflow.

My injector for forcing only is so constructed

that the working parts can be taken out, examined, and refixed without stopping engine, boiler, or disconnecting the injector, and will effect a saving in the consumption of fuel by the water being injected into the boiler at nearly boiling-point.

My non-regulating injector is the simplest injector that can be made; there are not any working parts; the two fixed parts can be removed, examined, and renewed in a few minutes; its action is certain, the right quantity of water being regulated by means of the ordinary steam-cock.

While in the foregoing specification the nozzle, spindle, and delivery nipple or cone have all three been described as spirally threaded or grooved, either the spindle or nozzle may be left plain, and may be used in an injector having a delivery nipple or cone with a plain internal surface.

What I claim is—

1. An injector having one or more of its interior surfaces adapted to guide water or steam spirally as it passes through said injector, substantially as described.

2. An injector having a steam-delivery nozzle provided internally with means for giving a spiral direction to steam passing there-through, and externally with means for guiding in a spiral direction the water flowing through the outer shell or casing of said injector, substantially as set forth.

3. The combination, with the shell or casing A, having water-inlet M and steam-inlet N, of the longitudinally-adjustable nozzle B, having lateral opening N', and provided with means for preventing its rotation, and the longitudinally-adjustable spindle D, having an enlarged portion, serving as a plug for the lateral opening of the nozzle, substantially as described.

4. In an injector, the combination of the casing A, having inward projection P, slotted adjustable nozzle B, screw-cap C, and its operating-wheel, substantially as described, whereby the nozzle may be adjusted in either direction without altering the length of the injector shell or casing.

5. The combination of the injector shell or casing A, having the steam-inlet N and a suitable water-inlet, with the longitudinally-adjustable nozzle B, having the lateral opening N', and provided with means to prevent its rotation, substantially as described.

6. An injector having an internally spiral threaded or grooved delivery-nipple, K, substantially as described.

JOSEPH ELTON BOTT.

Witnesses:

H. W. GOUGH, *Civil Engineer.*

J. H. GOUGH.