

J. W. HYATT.
Slate-Grinding Machine.

No. 209,265.

Patented Oct. 22, 1878.

FIG. 1.

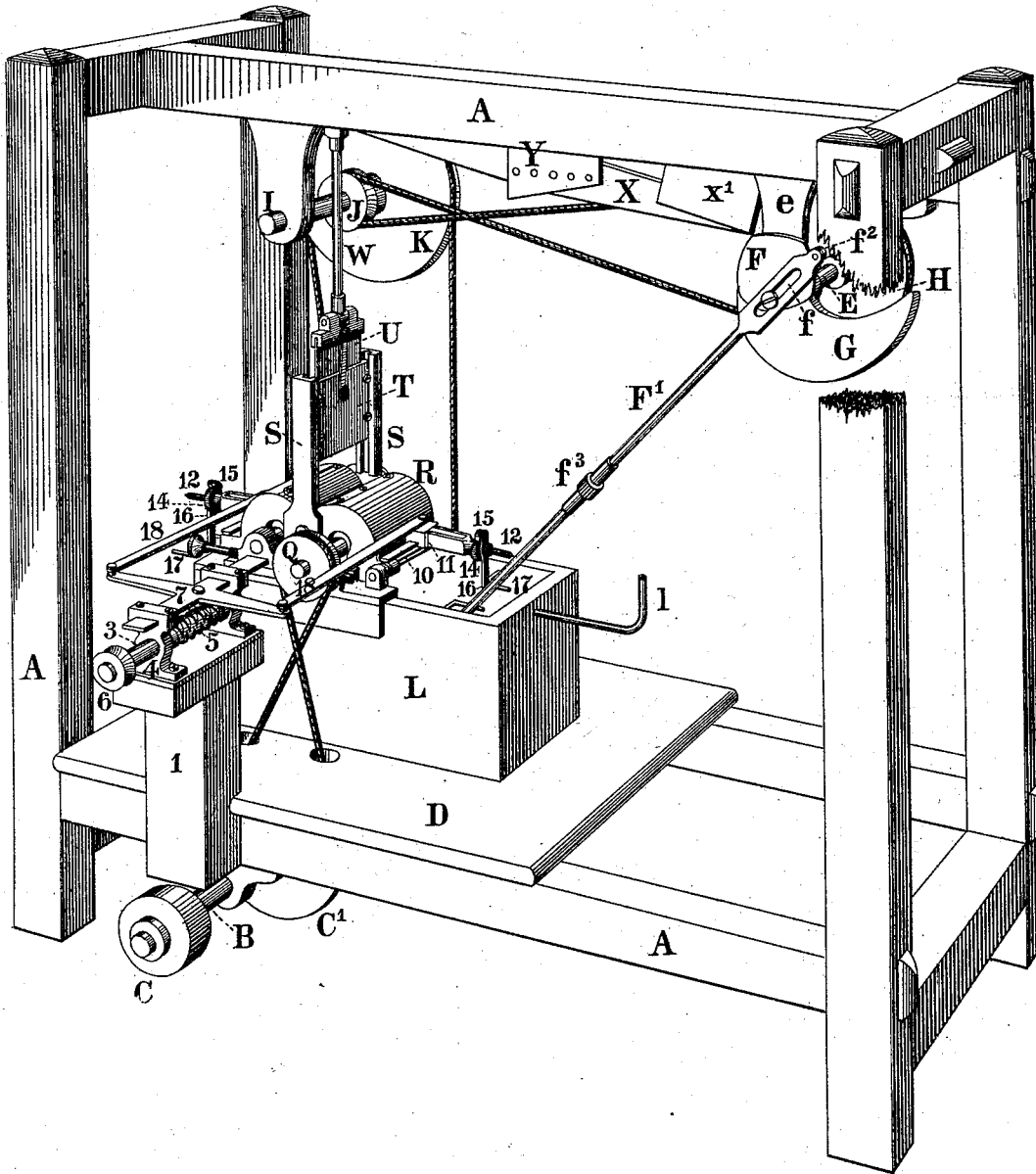

WITNESSES.

J. Thomson Bell.
J. Walter Douglass

INVENTOR.

John W. Hyatt.
by Henry Baldwin Jr.
Att'y

J. W. HYATT. Slate-Grinding Machine.

No. 209,265.

Patented Oct. 22, 1878.

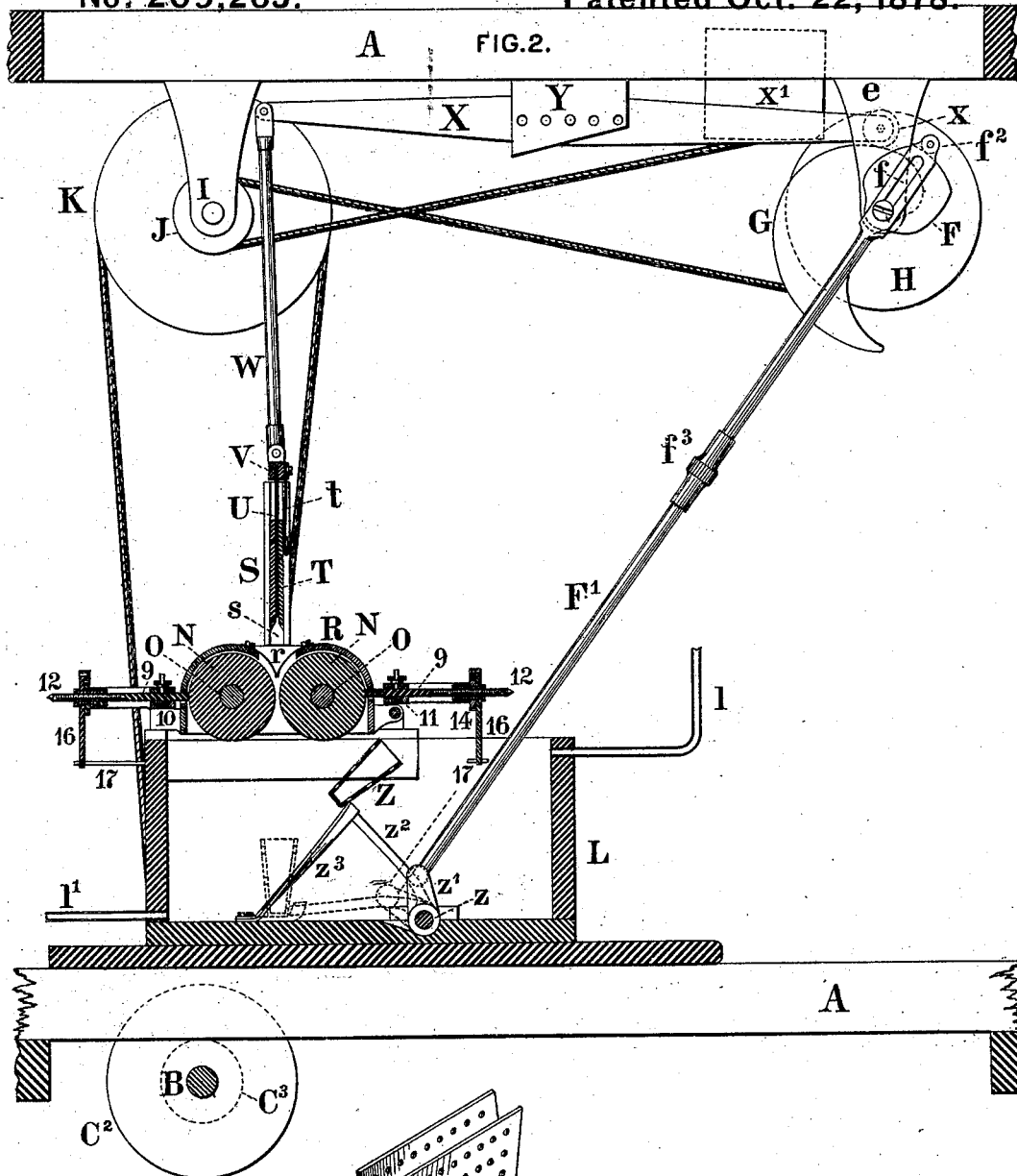

FIG. 5.

WITNESSES.

J. Snowden Bell,
J. Walter Douglass

INVENTOR.

John W. Hyatt.
by Henry Baldwin Jr.

J. W. HYATT.
Slate-Grinding Machine.

No. 209,265.

Patented Oct. 22, 1878.

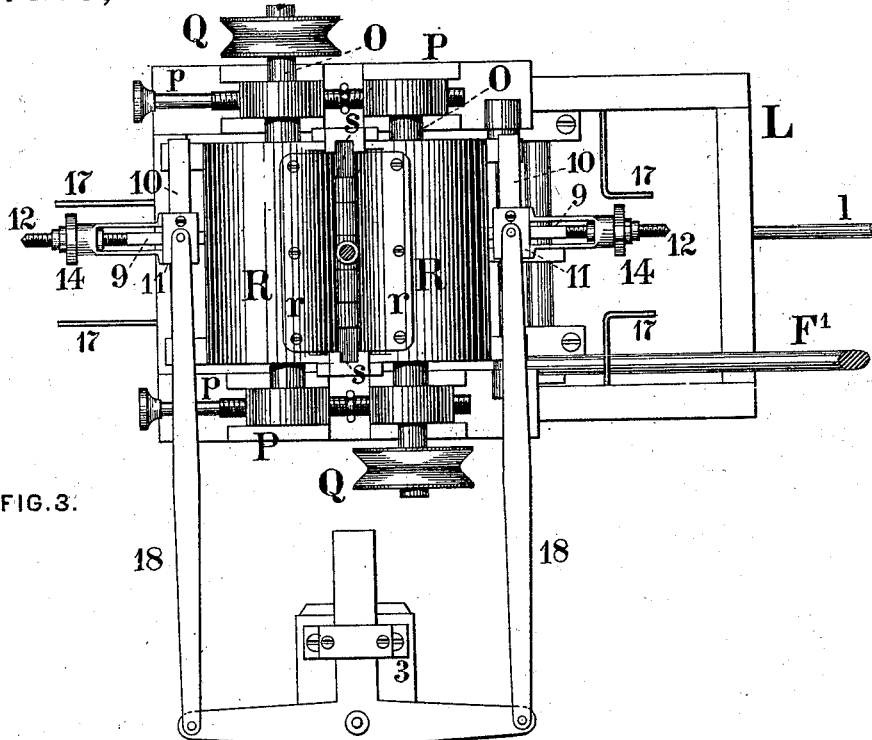

FIG. 3.

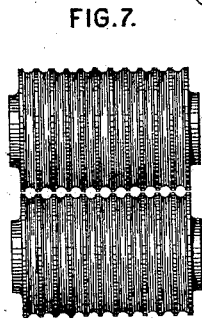

FIG. 7.

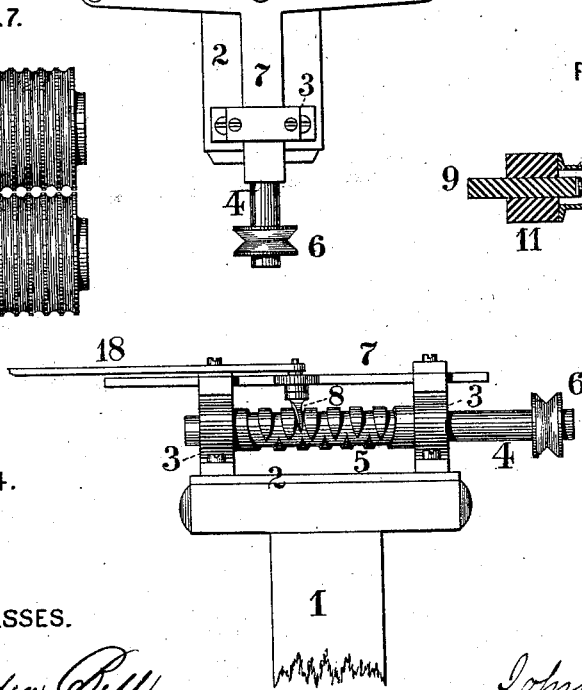

FIG. 4.

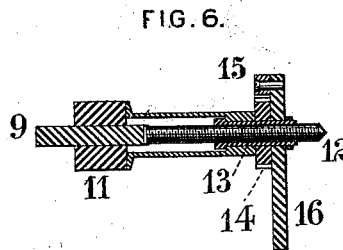

FIG. 6.

WITNESSES.

J. Thorden Bell,
J. Walter Douglass

INVENTOR.

John W. Hyatt,
by Henry Baldwin, Jr.
Att'y.

UNITED STATES PATENT OFFICE.

JOHN W. HYATT, OF NEWARK, NEW JERSEY.

IMPROVEMENT IN SLATE-GRINDING MACHINES.

Specification forming part of Letters Patent No. **209,265**, dated October 22, 1878; application filed June 28, 1878.

To all whom it may concern:

Be it known that I, JOHN W. HYATT, of Newark, in the county of Essex and State of New Jersey, have invented certain new and useful Improvements in Grinding and Shaping Machines, of which improvements the following is a specification, reference being had to the accompanying drawings, in which—

Figure 1 is a view, in perspective, of the machine. Fig. 2 is a vertical longitudinal section through the same. Fig. 3 is a plan or top view, on an enlarged scale, of the trough and of the mechanism mounted thereon or connected therewith. Fig. 4 is a side view, in elevation, of the traveler or endless-screw device for moving the truing-points to and fro along the surfaces of the rolls. Fig. 5 is a view, in perspective, of the automatic receiving and delivering carrier. Fig. 6 is a horizontal central section of the device for feeding up the truing-points, as hereinafter described; and Fig. 7 is a plan of the grooved surfaced grinding and shaping rolls.

The improvements herein claimed relate immediately to an apparatus for grinding and shaping slate, for which apparatus Letters Patent of the United States No. 204,151 have been granted and issued to me under date of May 28, 1878, the principles of my improved machine herein described being substantially the same as those of the apparatus described in my said prior patent, both for grinding and for grinding and shaping slate, using plane-surfaced rolls or grooved rolls, according to the work to be done, and grinding with water, as set forth in said patent, it being the special object of my present improvements to make that apparatus, as far as practicable, automatic; but as some of these improvements are equally applicable to machines for grinding other materials as well as slate, and for grinding without as well as with water, I do not mean to confine my claims to slate-grinding machines alone.

My invention consists, first, in providing the slab or plate to be ground or ground and shaped with support on both sides and on its upper edge, and feeding the slab or plate thus supported through the grinding or grinding and shaping rolls under positive vertical pressure instead of feeding it between feeding-rolls, as heretofore, by which improvement I not

only secure greater uniformity and evenness in the surfaces of the ground slab, but also avoid the jarring and liability to breakage which attend the use of feeding-rolls in conjunction with grinding-rolls, and the positive feed further insures perfect uniformity in the time during which the slab is fed to and acted upon by the grinding-rolls, so as to give the different stages of the automatic operation a regular succession.

Second, in automatically receiving, conveying and delivering the ground or ground and shaped slab from underneath the rolls to the top of the trough, where it is received by the helper, the unloaded carrier returning again to its place in time to receive the slab which has been fed down between the rolls while the previous one was being delivered.

Third, in automatically feeding up and traversing the truing-points to, and back and forth along, the surfaces of the grinding-rolls. This third feature of my improvements is applicable only to grinding or plane-surfaced rolls, and not to grinding and shaping or grooved surfaced rolls.

Fourth, in combining the feeding, the delivering, and the truing devices with the grinding-rolls, so that the operation of the machine is completed within the shortest time required for the proper passage of the slab between or through the rolls, the different parts being made adjustable, so that their movements can be readily adapted to any change in the size of the slab to be ground; and, fifth, in certain details of the mechanism, which will be hereinafter particularized.

The machine shown in the accompanying drawings, which form a part of this specification, is designed especially for grinding slate, or grinding and shaping slate-pencil blanks, the grinding or grinding and shaping being done with water, as set forth in my aforesaid Patent No. 204,151.

A strong frame, A, supports the apparatus, and affords points of attachment for the bearings of the driving-shaft B, carrying the pulleys C C¹ C² C³ below the flooring D, and of the shaft E, carrying the cams F G and the pulley H, and of the shaft I, carrying the pulleys J K.

Upon the flooring D, toward one end of the

frame, is mounted the trough L, which is simply a water-tight box of suitable length to accommodate the grinding-rolls, as shown, and to permit the traverse of the carrier Z, as will presently be described, and of a width adapted to the length of the rolls N N, which are supported on shafts O O, turning in boxes secured in guides upon the edges of the trough, as shown in the drawing. The supply and discharge pipes *l v* maintain a circulation of water through the trough, carrying off the accumulations of detritus. The rolls N N are mounted toward one end of the trough, as shown, so as to leave the top of the trough open for such a distance as will admit of the presentment by the carrier of the finished slate at the outside of the hood. The rolls are also mounted so that their under surfaces will be immersed in the water in the trough; and they are further so mounted that their boxes can slide in the guides P P toward and from each other, and thereby the rolls can be adjusted at different distances apart, as required, to permit the action of the rolls upon slabs of different thicknesses, and to compensate for the wear of the rolls. I have also applied to the boxes, at each end of the rolls N N, an adjusting-screw, *p*, having a right-hand thread for one of the boxes and a left-hand thread for the other, so that by means of these screws the rolls can both be moved toward or away from each other. Pulleys Q Q are mounted on the shafts of the rolls, and these pulleys are driven by belts from the pulleys C¹ C², respectively.

The hood R incloses the rolls and prevents the splashing of the water. This hood is hinged at one end, so that it may be turned back when it is desired to get at the rolls. The hood has a transverse slot on each side, extending along the entire length of the roll, and through these slots the truing-points, to be presently described, are inserted, so as to bear upon the surfaces of the rolls and keep them true and even.

At a point coinciding with the space between the rolls N N, the hood R has an opening through it, which opening extends the entire length of the rolls, and through this opening the slab is fed to the rolls, as will presently be described. To prevent the slab from dropping down between and upon the rolls before the feed-pressure is applied, I have placed a spring-plate, *r*, on each side of this opening, securing the plates to the hood by their upper edges in such manner that their free lower edges will come close together, (see Figs. 2 and 3,) and bear firmly upon the sides of the slab as it passes down through the opening and between the rolls.

An upright, S, is secured to the hood at each end of the feed-opening, and in each of these uprights is a guideway, *s*, for the feed-gate. This feed-gate consists of a hollow box, T, fitting loosely in the guideways *s*, and a plunger, U, fitting loosely in the box T, and

sliding up and down through the box as the box slides up and down in the guideways *s*. The upper edge of the plunger is fitted into a cross-head, V, and this cross-head and the box T are connected by a strap, *t*. A rod, W, pivoted to the cross-head V, extends upward, and is pivoted at its upper end to the corresponding end of the oscillating arm or walking-beam X, so that as this end of the beam X descends, lowering the plunger U, the box T slides down to the bottom of the guides *s*, affording a firm and steady bearing and support throughout its entire width and depth to that part of the slab which is within it. The plunger then follows, with its lower edge bearing upon the upper edge of the slab thus supported in the sliding box, and forces the slab down between the spring-plates and between the rolls until the upper edge of the slab has passed below the center of the rolls, by which time the opposite end of the walking-beam has reached its greatest elevation, when the weighted end of the arm falls, and first lifts the plunger up through the box as far as the strap *t* will allow, and then lifts both the plunger and the sliding box until the opposite end of the walking-beam has reached its greatest depression, when the attendant places another slab under the sliding box, to be fed down as before.

When the slabs are thin, as for school-slates, the lower edge of the plunger is grooved, so as more readily and evenly to bear upon the upper edge of the slab, and the upper edge of the slab should be shaped to fit snugly in this grooved edge of the plunger. When the slabs are thick, or when the material to be ground or ground and shaped is not liable to spall off under the feed-pressure, the sliding box T is dispensed with, the plunger fitted to the guides *s*, and the slab simply placed by the operator under the lower edge of the plunger and upon the spring-plates *r*, and in such case the lower edge of the plunger will not require to be grooved, nor the upper edge of the slab to be conformably shaped.

The oscillating arm or walking-beam X is pivoted in a plate or bracket, Y, depending from the frame A at the center of its length, or more or less away from that point, according to the desired range of the up-and-down movement of the end which is connected to the plunger, conformably to the requirements of different lengths of slabs, holes being provided in the arm, and coincidentally in the bracket, as shown, for this adjustment. As has been already described, one end of this beam X is attached to the rod W, which operates the plunger U and sliding box T. The opposite end of the arm X extends back to the shaft E, and has a roller, *x*, which rests or moves upon the cam G, as presently to be described.

A weight, *x'*, is placed upon the arm X, between the roller and the point of suspension of the arm, which weight insures the depression of that end of the walking-beam and the

raising of the feed-gate when the portion of the cam having the greatest radius has passed the roller.

The shaft E is supported and turns in bearings in brackets *ee* depending from the frame A, and this shaft derives motion through the pulley H, driven by a belt from the pulley J on the shaft I, which is in turn driven through the pulley K by a belt from the pulley C³ on the driving-shaft B. The cam G is fixed upon this shaft E, close to the inside of the inner bracket, *e*, and the cam F is secured upon the outer end of the shaft E on the outside of said bracket.

The throw of the cam G must be such as to give the roller end of the walking-beam lift enough to feed down the plunger U, as already described.

As slabs of different lengths will require variations in the extent of these movements of the walking-beam and plunger, I provide for such variations by making a series of holes in the bracket Y coincident with a corresponding series in the beam X, so that the point of suspension of the beam may be changed as required, to increase or diminish the movements of the plunger relatively to those of the roller end of the walking-beam.

The cam G, raising the roller end of the oscillating arm or walking-beam and correspondingly depressing the opposite end, forces down the plunger and feeds the slab through the sliding box and between the rolls with a positive vertical pressure, while the sliding box, as already stated, supports the slab on its sides and edges; so that the slab, instead of being shaken and cramped, as when feed-rollers are employed, and instead of being broken, as it is so liable to be when fed between feeding-rolls and to grinding-rolls, as heretofore, is firmly but gently fed down with a positive motion and at a regulated speed, conforming exactly with the action of the grinding-rolls, which have only to reduce the surface as the slab is fed between them.

The cam raises the roller end of the arm X with the proper speed and in proper time for the due feeding of the slab to the rolls, and corresponding also with the delivery of the finished slate, which delivery is effected as follows: In the bottom of the trough L, I secure a horizontal shaft, *z*, so that it shall roll in its bearings, and on one end of this shaft, which projects beyond its bearing, I secure a crank, *z*¹, provided with a crank-pin. (See Fig. 5.) About midway of the shaft *z*, I secure an arm, *z*², of such length as to reach, when horizontal, from the shaft to the center line of the space between the grinding-rolls, and, when raised, from the shaft to near the top of the trough, as shown in Fig. 2 by the dotted lines and the full lines respectively. Of course the position of the shaft in the trough must be such as to allow of this range of movement of the arm *z*².

A rod, F', is connected at its lower end to the pin on the crank *z*¹ and extends back to

the cam F, the upper end of this rod having a longitudinal slot, *f*, in it, through which slot a screw connects it with the side of the cam. Above this slot the extreme upper end of the rod has a laterally-projecting friction-roller, *f*², which rests upon the face of the cam F. To provide for the adjustment of this rod I make it in two parts, and connect these parts by an adjusting-screw, as at *f*³, Fig. 2.

Upon the end of the arm *z*¹ I secure a perforated receiver and carrier, Z, so that it shall extend across the trough underneath the space between the grinding-rolls to receive the slab as it leaves the rolls. A yielding spring, *z*³, is secured by one end to the bottom of the trough, and by the other to the arm *z*¹, so that this spring holds the arm down until the roller *f*² on the cam F raises the carrier, extending the spring until the carrier is unloaded by the helper, by which time the roller *f*², having passed along the face of the cam F and over its greatest radius, the spring *z*³ draws the carrier back to its position in the bottom of the trough.

As the carrier is retracted by the spring the roller *f*² passes down along the shorter radius of the cam, the slot in the rod F' permitting this movement. The cam F is formed as shown in the drawing, Figs. 1 and 2, and its action relative to that of the cam G on the same shaft is such that when the plunger has forced the slab down between the rolls the carrier is in place beneath the rolls to receive the slab. When the cam G releases the roller on the end of the arm X, and the weight *x*' brings the roller down again upon the side of the cam opposite to that which raised it, thus raising the plunger and the sliding box, so that the workman can put another slab under the plunger, the friction-roller, traveling along the edge of the cam F, at the same time lifts the carrier, with the finished slab in it, bringing the mouth of the carrier to the top of the trough behind the rolls, where the helper stands ready to remove the finished slab; and through the action of the spring *z*³ the carrier is again returned to its place under the rolls before the next slab has been fed through them. By this device I am enabled to operate the machine continuously without stopping it to remove the finished slabs, as is necessary in the absence of an automatic delivery.

In my former patent, No. 204,151, I have explained the necessity of correcting the unevenness which is soon produced in the surfaces of the grinding-rolls, and have described means of making this correction by traversing points moved along the surfaces of the rolls, suggesting that this movement might be effected by any of the well-known devices for giving a reciprocating traverse to a holder along the guides; but in the present instance I have invented a means of doing this particular work, not only traversing, but also feeding the points automatically, which is simple, effective, and complete, and I believe it to be entirely new.

I secure a strong upright post, 1, to the frame-piece A, and on this post I mount a bed-plate, 2, at right angles to the trough L, and at each end of this bed-plate I mount one of the boxes 3, in which a shaft, 4, turns. This shaft 4 is, as to that part which is between the boxes, an endless screw or a traveler, 5, Fig. 4, and on the projecting end of the shaft 4 I mount the pulley 6, which is driven by a belt-connection from a proper counter-shaft. The upper part of each of the boxes 3 has a guideway, in which a sliding bar, 7, is moved longitudinally to and fro parallel with the traveler, as follows: A forked collar, or half-nut, 8, which fits into the threads of the endless screw or traveler 5, is secured to the sliding bar 7, so that as the shaft 4 is rotated the bar is moved in one direction until the collar reaches the end of the travel of the screw in that direction, and when this limit is reached the collar takes into the reverse thread of the screw and carries the sliding bar back to the other extremity of its traverse.

The truing-points 9 are mounted, and are moved to and fro along the surface of the rolls, as follows: Being duplicates of each other, I shall describe only a single one. A flat bar, 10, is bolted across the hood, parallel with and a little below the slot. A sliding box, 11, is fitted on this bar 10, and in this sliding box is a recess, in which the truing-point 9 is fitted and secured by a cap-plate, the truing-point being susceptible of end motion, and projecting forward from its box, so as to enter the slot in the hood and bear upon the surface of the roll, and also projecting backward between the arms of the bar, so as to be borne upon by the feeding-screw 12. This feeding-screw 12 engages a nut, 13, of corresponding pitch, which nut is mounted in a bearing on the arms of the box 11 and rotates freely, but without end motion therein, so that the rotation of the nut will impart end motion to the screw, and thereby to the truing-point, against which the screw bears. To impart this feed-motion automatically, I secure a ratchet-wheel, 14, upon the nut, and operate this ratchet by a pawl, 15, pivoted upon the upper end of a double-armed lever, 16, mounted loosely upon the nut, and I operate this lever by bringing its lower end against stop 17, projecting from the trough at the extremities of the travel of the sliding box 11 to and fro along the bar 10, so that in every alternate traverse of the truing-point along the roll the ratchet will feed up the truing-point more or less, according to the greater or less distance between the stops, which distance the operator will adjust to suit the required rate of feed. The sliding boxes 11 are connected with the sliding bar 7 by parallel links 18, and thus the traveler 5 moves the truing-points back and forth along

the rolls, and also effects the feeding up of the points, as already described, through the depending arms of the levers 16 and the stops 17. This device for traversing and feeding up the truing-point may also be used in machines which have no grinding-rolls—as, for example, the truing-point may be a chisel or other finishing-tool; and I contemplate using it in other machines, and claim it when applied to other analogous mechanism.

It will be seen from the foregoing that with this machine it only requires an attendant to place the rough slab under the plunger and a helper to unload the carrier Z, all the rest of the operations being automatic.

For grinding and shaping slate-pencil blanks, I substitute the grooved rolls, Fig. 7, for the plane-surfaced rolls, and disconnect the traveler from the truing-points, so that the boxes 11 remain stationary.

Having thus described the nature and objects of my improvements, what I claim herein as new, and desire to secure by Letters Patent, is—

1. The combination, with the grinding-rolls, of the sliding box T and the plunger, whereby the slab is supported and steadied and fed to the grinding-rolls by a positive motion, substantially as and for the purposes described.

2. The combination, with the grinding-rolls, of the spring-plates *r*, supporting the lower edge of the slab, and the feed-plunger U, bearing upon the upper edge of the slab, substantially as and for the purposes set forth.

3. The combination, with the grinding-rolls, of the hood, the spring-plates for preventing the slab from falling into the rolls, the sliding box, and the plunger, substantially as described.

4. In combination with the feeding mechanism and the grinding-rolls of a slate-grinding machine, the automatic carrier for delivering the finished slab, substantially as described.

5. The combination, with the feeding-plunger, of the guides in which the plunger moves vertically, and the adjustable walking-beam for varying the feed conformably to the requirements for different lengths of slabs, substantially as described.

6. The combination, with a grinding-roll, of an automatic device for traversing and feeding up the truing-points, substantially as described.

7. The combination of a truing-point, a traveler, and a feeding device, substantially as described.

JOHN W. HYATT.

Witnesses:

W. F. PLUME,
WM. PLUME.