

R. A. JOHNSON.
Tappet for Stamp-Rod.

No. 209,269.

Patented Oct. 22, 1878.

Fig. 1

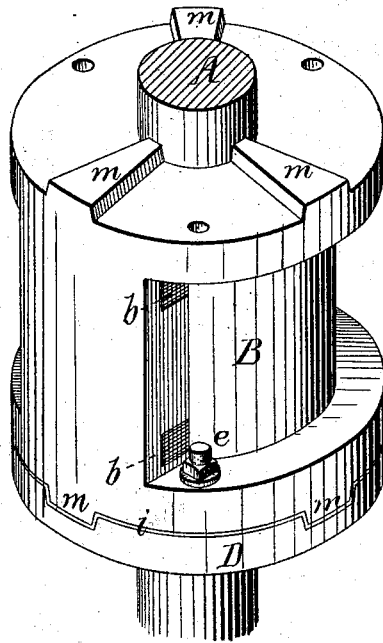

Fig. 2

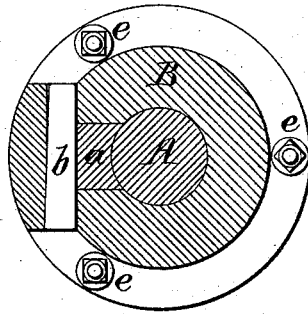
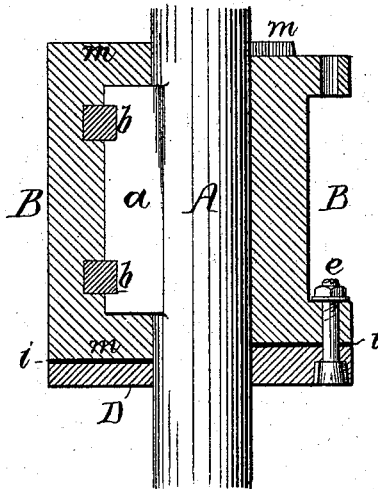

Fig. 3



Witnesses
J. McDermott
Henry Smith

Inventor
Robert A. Johnson
by his Attorneys
Howson and Co.

UNITED STATES PATENT OFFICE.

ROBERT A. JOHNSON, OF PHILADELPHIA, PENNSYLVANIA.

IMPROVEMENT IN TAPPETS FOR STAMP-RODS.

Specification forming part of Letters Patent No. **209,269**, dated October 22, 1878; application filed July 24, 1878.

To all whom it may concern:

Be it known that I, ROBERT A. JOHNSON, of Philadelphia, Pennsylvania, have invented a new and useful Improvement in Tappets for Stamp-Rods, of which the following is a specification:

The object of my invention is to construct a tappet for the stamp-rod of a crushing-mill in such a manner that said tappet will be more durable than usual. This object I attain in the following manner, reference being had to the accompanying drawings, in which—

Figure 1 is a perspective view of my improved tappet for stamp-rods; Fig. 2, a sectional plan view of the same, and Fig. 3 a transverse vertical section.

A represents one of the stamp-rods of a mill for crushing ore, &c.; and B, a tappet, consisting of a cylinder with flanged ends, said tappet being secured to the bar by means of the usual gib *a* and keys *b b*.

Ordinarily the lifting-cam acts directly on the lower face of the tappet, and when the faces of the latter become worn to a certain extent the entire tappet must be discarded as worthless. This is objectionable, as the tappets are expensive, owing to the fact that in addition to the first cost of the same must be added the greater cost of transporting them to the remote regions where they are generally used.

Attempts have been made to overcome the difficulty by chilling the faces of the tappet; but this is also objectionable, as it is almost impossible to effectively bore a properly-chilled tappet for the reception of the stamp-rod.

In carrying out my invention I make the tappet of cast-iron, and secure to the lower face of the same, by means of bolts *e*, a ring, D, of chilled iron or steel, the lifting-cam acting on the face of this ring, which, when worn,

can be readily removed and replaced by a new one.

In order to insure the firm seating of the ring on the tappet, so as to prevent jarring, I interpose between the ring and the face of the tappet a thin ring, *i*, of paper, leather, or like elastic or semi-elastic material, which is compressed by the ring D when the latter is bolted into place.

Lateral strain on the bolts *e* is prevented by recessing the upper surface of the ring D, and providing the faces of the tappet with corresponding ribs or projections *m*, the object of providing both the upper and lower faces of the tappet with these ribs being to permit the reversing of said tappet in case of injury to the lower end of the same.

It will be evident that by the above method of construction the wear of the tappet itself by the lifting-cam is entirely overcome, and that said tappet therefore possesses the desired advantages of durability and freedom from accidental breakage to a much greater extent than a tappet constructed in the usual manner.

I claim as my invention—

1. The tappet B, having radial ribs *m* on one or both faces, as set forth.
2. The ring D, having in its upper face radial recesses for the reception of corresponding ribs on a tappet, as set forth.
3. The combination of the recessed ring D, the bolts *e*, and the tappet B, having radial ribs *m* on one or both faces, as specified.

In testimony whereof I have signed my name to this specification in the presence of two subscribing witnesses.

ROBERT A. JOHNSON.

Witnesses:

HARRY A. CRAWFORD,
HARRY SMITH.