

J. W. MANARD.
Hose-Reel.

No. 209,278.

Patented Oct. 22, 1878.

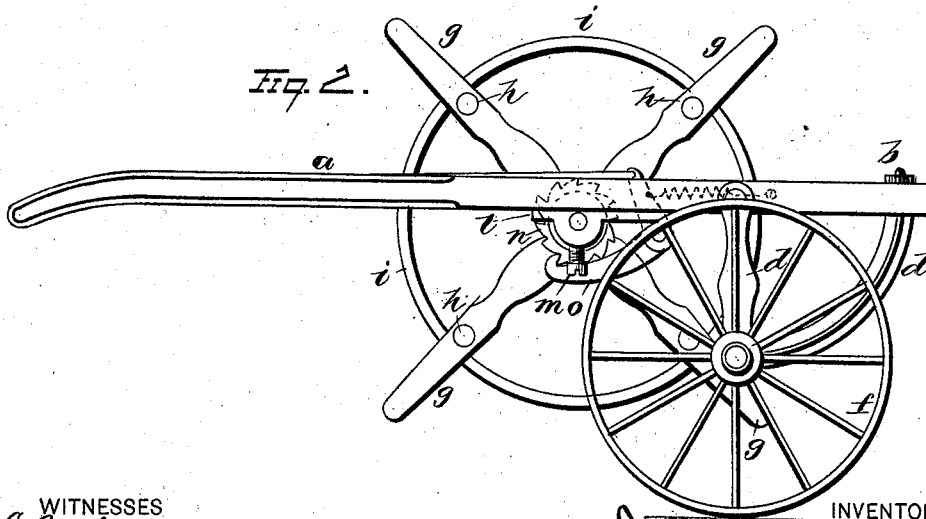
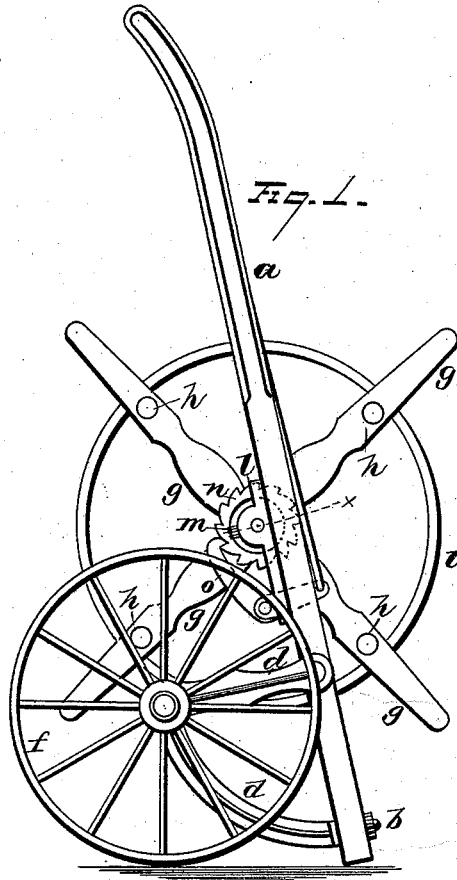

WITNESSES
E. D. Nottingham.
A. M. Baugh.

INVENTOR
James W. Manard
By *H. A. Seymour.*
ATTORNEY

J. W. MANARD.
Hose-Reel.

No. 209,278.

Patented Oct. 22, 1878.

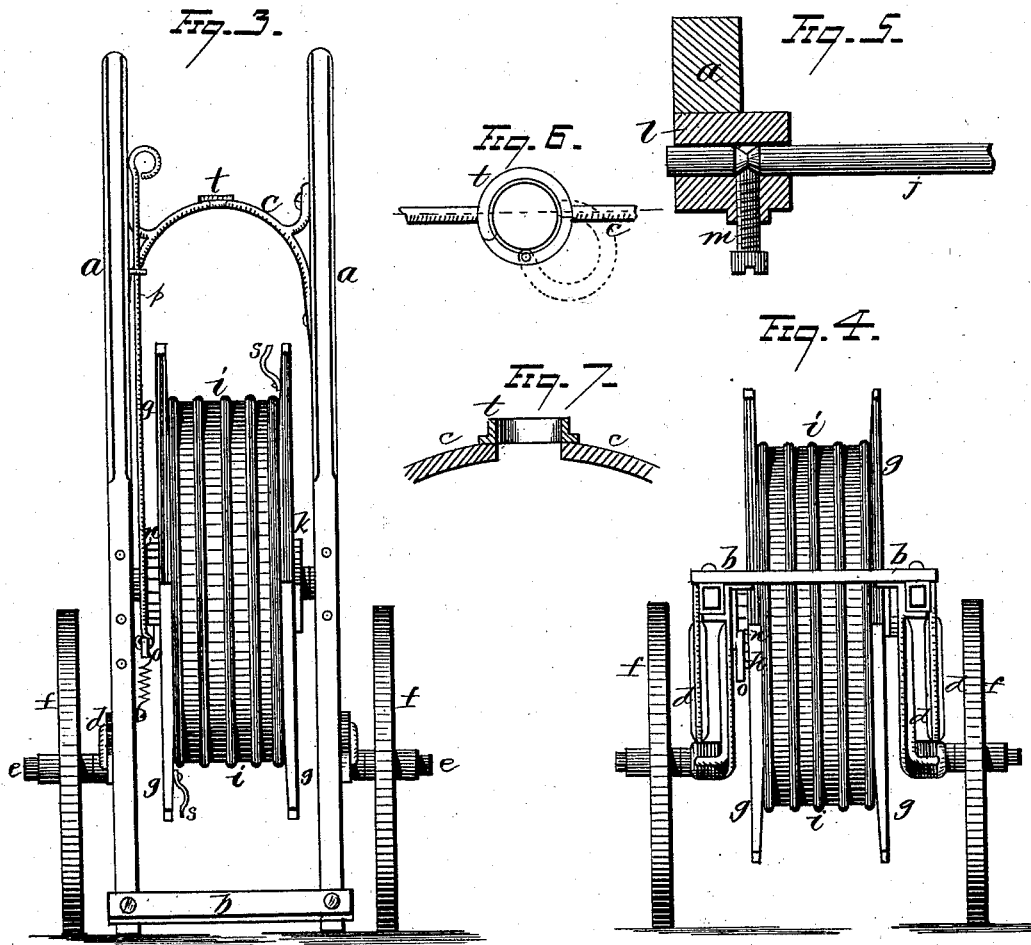

WITNESSES
E. J. Nottingham
A. M. Bright

INVENTOR
James W. Manard
By *A. A. Seymour*
ATTORNEY

UNITED STATES PATENT OFFICE.

JAMES W. MANARD, OF ROCKFORD, ILLINOIS.

IMPROVEMENT IN HOSE-REELS.

Specification forming part of Letters Patent No. 209,278, dated October 22, 1878; application filed September 13, 1878.

To all whom it may concern:

Be it known that I, JAMES W. MANARD, of the city of Rockford, in the county of Winnebago and State of Illinois, have invented a new and useful Improvement in Hose-Reels, of which the following is a specification:

This invention relates to that class of reels known as "yard-hose reels," designed for handling yard-hose in connection with yard-hydrants.

The object of this invention is to produce a reliable reel at a small cost, capable of all the uses of the more expensive reels, and to provide the reel with a cylindrical drum on which to wind the hose, fitted with a ratchet and pawl to hold the reel in position, and other minor improvements, which will be hereinafter more fully described.

In the drawings, Figure 1 is a side elevation of my improved reel in a self-supporting position. Fig. 2 represents its position in transportation. Fig. 3 is a front elevation in a self-supporting position. Fig. 4 is a front-end view, with the main frame in a horizontal position. Fig. 5 is a transverse section through one of the sides on dotted line X, Fig. 1. Fig. 6 is a plan view of the nozzle-support in the center of the bracket connecting the handle portion of the side beams to the frame. Fig. 7 is a lengthwise vertical central section of the same.

In the figures, *a a* are the side beams of the main frame, which are made of any suitable material and of proper size, and are connected at their forward ends by a suitable cross-bar, *b*, and toward their handle ends by the curved bracing-bracket *c*. The rear ends of these side beams are finished in a suitable handle form. *d d* are depending bracket-arms, secured to the side beams and forward cross-bar of the main frame. The depending portions of these bracket-arms are provided with axle-arms *e*, which project outward, and are fitted to receive the carrying-wheels *f*, to revolve thereon. These parts, constructed as described and shown, form the carriage, on which the hose-reel is mounted to revolve in suitable bearings.

The hose-reel is composed of two heads, formed of bars *g*, which cross each other in the center of their length, halved on each other to produce an even side surface. These head-

frames are separated a proper distance, and fixed in such separated relative positions by means of suitable rounds *h*, framed into each opposite pair of arms about midway of their length.

i represents a rim, made of plate material, preferably of iron galvanized and corrugated, which is supported between the end frames of the reel on the rounds *h*. The object of this rim is to prevent the abrupt bending of the hose at the several cross-rounds, as in reels without the rim, which tends to check the flow of water, and soon breaks the hose at each bend. This reel is supported by a shaft, *j*, which is passed through the center of the end frames and through metallic hubs *k*, fixed to the centers of their outer faces. The outer ends of this center shaft are fitted to revolve in bearings *l*, fixed to the rear or under face of the side beams. The bearing portions of the center shaft are fitted with grooves, which receive the conical ends of the screws *m*, passed through the bearings. This construction serves to prevent the side beams from spreading, and still permits the shaft to revolve, and the length of the bearing serves to give additional firmness to the frame.

n represents a ratchet-wheel fixed to the reel. A spring-pawl, *o*, fixed to the frame, engages the teeth of the ratchet to hold the reel, and prevent the hose from unwinding or running from the reel. *p* is a wire connected to the spring-pawl, and extending within easy reach of the handle ends of the side beams, by means of which the operator may disengage the pawl to permit the reel to revolve and pay out the hose when required. *s s* are loops attached to the reel-arms, and are designed to receive the ends of the hose when wound on the reel, to prevent it running therefrom. The center of the bracing-bracket *c* is made in a semicircular loop form, to secure the nozzle end of the hose, and is provided with a swinging semicircular clasp, *t*, pivoted thereto in such a manner as to permit it to swing open, as represented in dotted lines, Fig. 6, to admit the hose, after which it can be turned into the position represented in solid lines to confine the hose in the loop. This center loop is employed mainly for purposes of sprinkling, or when the hose is used as a fountain. This center

loop may be formed with an upward-projecting flange surrounding the opening, substantially as represented in the figures.

By this construction I am enabled to produce a hose-reel carriage in which the forward ends of the side beams of the frame form the feet on which, in connection with the carrying-wheels, the machine is supported when in an upright position, in which the reel, mounted in the frame, will be supported about on the vertical center between the bearing-points of the carrying-wheels and the foot end of the side beams. When in position for transportation, as represented in Fig. 2, the reel will be a proper distance rearward of the carrying-wheels to properly balance the machine.

I claim as my invention—

1. A hose-carriage frame consisting of side bars which extend rearward of the carrying-wheels and are provided with depending brackets, each of which is formed with two arms, one of said arms secured to the rear end of the carriage-frame and the other to that portion of the frame nearest the axle, the lower end of said brackets provided with axle-arms for supporting the carrying-wheels, substantially as set forth.

2. The combination, with a reel-frame, of a metallic hose-supporting rim or shell secured between the end frames of the reel, said rim constructed with a series of parallel grooves, substantially as set forth.

3. The combination, with a hose-reel, of a reel-supporting axle constructed with grooved journals, and bearings attached to the side beams of the carriage, said bearings provided with set-screws, the inner ends of which engage with the grooves in the axle-journals, substantially as set forth.

4. The combination, with a hose-reel having a ratchet-wheel secured thereto, of a spring-pressed pawl pivoted to the carriage-frame and a rod attached to the pawl-arm, said rod leading to the forward end of the carriage-frame, substantially as set forth.

5. The combination, with the cross-brace, of the swinging loop to embrace the nozzle, as and for the purpose set forth.

JAMES W. MANARD.

Witnesses:

W. MEAD,
A. B. MANARD.