

H. SOUTHWORTH.
Cut-Offs.

No. 209,301.

Patented Oct. 22, 1878.

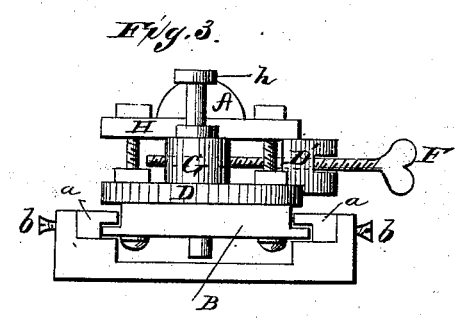
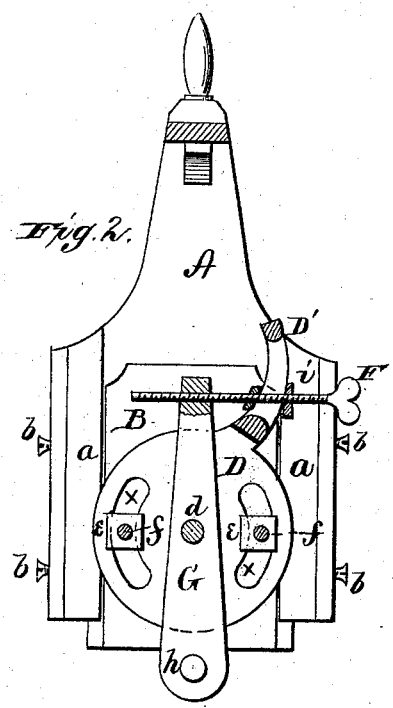
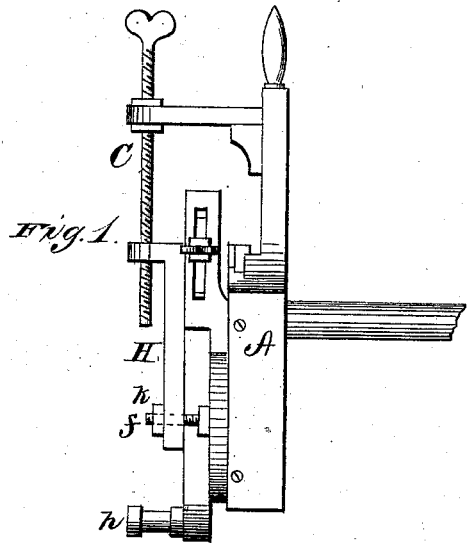

WITNESSES
F. L. ...
J. J. ...

INVENTOR
Henry Southworth
 BY *Alexander ...*
 ATTORNEYS

UNITED STATES PATENT OFFICE.

HENRY SOUTHWORTH, OF ALFORDSVILLE, INDIANA.

IMPROVEMENT IN CUT-OFFS.

Specification forming part of Letters Patent No. **209,301**, dated October 22, 1878; application filed July 10, 1878.

To all whom it may concern:

Be it known that I, HENRY SOUTHWORTH, of Alfordsville, in the county of Daviess, and in the State of Indiana, have invented certain new and useful Improvements in Valve-Regulators for Steam-Engines; and do hereby declare that the following is a full, clear, and exact description thereof, reference being had to the accompanying drawings, and to the letters of reference marked thereon, making a part of this specification.

The nature of my invention consists in the construction and arrangement of a device for regulating or adjusting the cut-off valves for steam-engines, as will be hereinafter more fully set forth.

In order to enable others skilled in the art to which my invention appertains to make and use the same, I will now proceed to describe its construction and operation, referring to the annexed drawing, in which—

Figure 1 is a side elevation of my invention. Fig. 2 is a front view of the same with the top plate removed. Fig. 3 is a view from the lower side thereof.

A represents an arm attached to the ordinary rock-shaft, from which the cut-off valve is operated. This arm is provided with adjustable guides *a a*, in which is placed the plate B, said plate being adjusted up and down by means of the screw C, and when adjusted as required it is held stationary by setting up said guides *a a* by means of set-screws *b b*.

From the plate B projects a center bolt, *d*, on which is placed a wheel or disk, D, formed with a projecting slotted arm, D'. The wheel D is adjusted on the bolt *d*, and held stationary by means of nuts *e e* upon two bolts, *f f*, which are passed through the plate B and through curved slots *x x* in the wheel or disk, as shown in Fig. 2.

On the bolt *d* is placed an arm, G, which has a wrist-pin, *h*, at its lower end for the cam-rod of the engine to work on.

Through the slot in the arm D' is passed a screw, F, with a nut or collar, *i*, on each side, and the end of this screw is screwed through the upper end of the arm G for adjusting the same, as required.

H is a top plate covering the mechanism, and held by nuts *k* on the bolts *f f*, as shown. It will readily be seen that by the various

adjustments, as described, the cut-off valve can be regulated to a nicety, and that at any time without stopping the engine.

The cam-rod from the engine being connected to the wrist-pin *h*, as above stated, the entire device obtains a reciprocating motion, which is imparted to the rock-shaft, from which the cut-off valve is operated. The stroke of the valve is regulated to a nicety by the adjustment of the various parts, as described, as such adjustment regulates the throw of the arm A, and consequently also the motion of the rocking shaft, to which said arm is attached.

The object of the circular disk D is to disconnect the valve from its operating mechanism without raising the cam-hook off the wrist-pin *h*.

By loosening the two nuts *f f* it will readily be seen that the arm G and disk D will rock on the center pivot without moving the arm A. The screw F that moves the arm G either way is to make the stroke of the valve equal on either end.

Having thus fully described my invention, what I claim as new, and desire to secure by Letters Patent, is—

1. The combination of the rock-shaft arm A, plate B, with adjusting-screw C, the adjustable guides *a a*, and the set-screws *b b*, substantially as and for the purposes herein set forth.

2. In combination with the rock-shaft arm A, the adjustable plate B, carrying the adjustable arm G, with its wrist-pin *h*, for the purposes set forth.

3. The combination of the adjustable wheel D, with slotted arm D', the arm G, with wrist-pin *h*, and the screw F, with collars or nuts *i i*, as and for the purposes set forth.

4. The combination of the rock-shaft arm A, plate B, with adjusting-screw C, wheel D, with slotted arm D', arm G, adjusting-screw F, and top plate H, substantially as and for the purposes herein set forth.

In testimony that I claim the foregoing I have hereunto set my hand this 21st day of May, 1878.

HENRY SOUTHWORTH.

Witnesses:

STANCLIFF C. ALLEN,
FRANCIS HEDRICK.