

E. A. BALDWIN.
Spinning-Mule.

No. 209,317.

Patented Oct. 29, 1878.

Fig: 1.

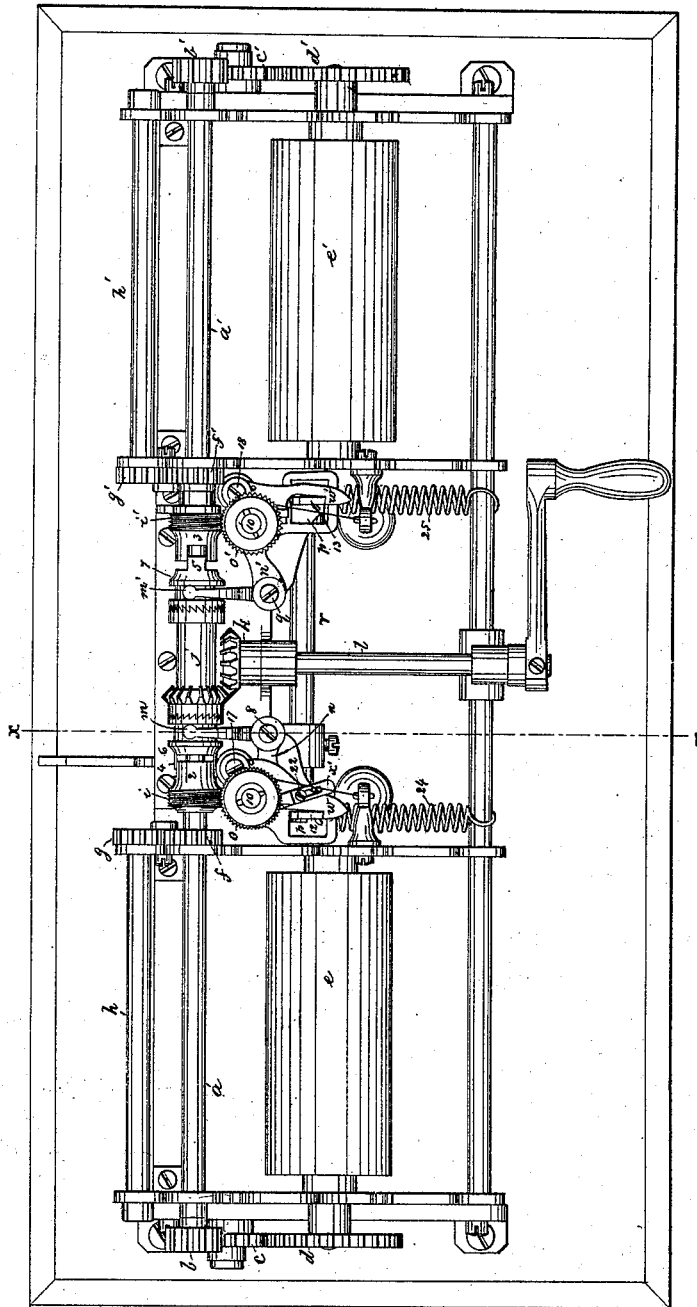

Witnesses.

N. C. Whitney,
L. F. Connor.

Inventor.

Eben. A. Baldwin
by Crosby & Gregory, Attys.

E. A. BALDWIN.
Spinning-Mule.

No. 209,317,

Patented Oct. 29, 1878.

Fig:2.

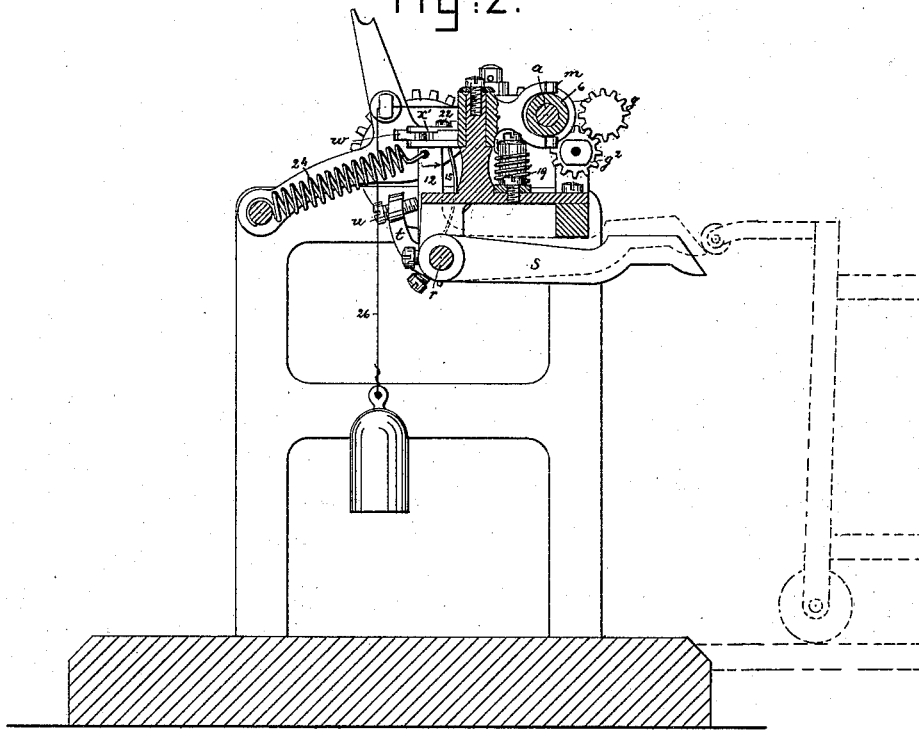

Fig:3.

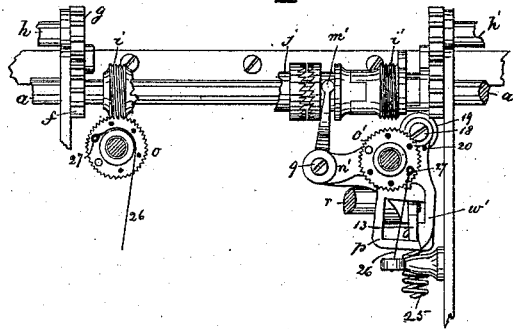
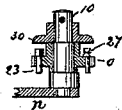

Fig:4.



Witnesses:

N. C. Whitney
L. F. Connor

Inventor.

Eben A. Baldwin
by Crosby Gregory

UNITED STATES PATENT OFFICE.

EBEN A. BALDWIN, OF NORTH ANDOVER, MASSACHUSETTS, ASSIGNOR TO
GEO. L. DAVIS, JOHN A. WILEY, JOS. M. STONE, GEO. G. DAVIS, JOSEPH
H. STONE, AND JAMES H. DAVIS.

IMPROVEMENT IN SPINNING-MULES.

Specification forming part of Letters Patent No. 209,317, dated October 29, 1878; application filed
July 20, 1878.

To all whom it may concern:

Be it known that I, EBEN A. BALDWIN, of North Andover, county of Essex, State of Massachusetts, have invented an Improvement in Spinning-Mules, of which the following description, in connection with the drawings forming part thereof, is a specification.

This invention relates to mules for spinning, and has for its object such a construction of the devices and mechanism for operating the delivering-rolls that one portion of the line of rolls may be run for a longer time than the other portion, so that the portion of the rolls which continue in motion and deliver the rovings of least weight while the other portions stop may deliver a greater length of roving than the other portion operating upon the largest roving, the movements of the carriage stretching the rovings so delivered, so as to make of uniform size all of the yarns or threads spun simultaneously upon the mule from rovings of unequal size and weight.

It is a well-known fact that the rovings first taken from the carding-cylinder by the cylindrical top doffer rob wool from the adjacent layers of wool, which are to be subsequently removed by the bottom doffer, and called the "second rovings," and that the second rovings therefore contain less stock and are of less weight than those first removed from the main cylinder.

For the manufacture of the best goods it is considered essentially necessary that all the threads of like quality be of like or uniform size and weight, and these rovings have been separated and spun at different times, which for many reasons is objectionable. In this my invention these rovings of unequal size and weight are placed at opposite ends of the two sets of delivering-rolls, and the rolls operating upon the rovings of greatest size are made to stop their delivery, as the carriage and spindles move from the rolls, before those which operate upon the second or smaller rovings, and consequently the heavier or first rovings are stretched or elongated more in proportion to their length than, and so as to

be equal in size and length with, the smaller or second rovings, this operation resulting in producing threads of uniform size and weight from rovings of unequal diameter and weight.

Figure 1 represents, in top plan, a portion of the head-stock of a mule, showing the lower rolls of the set of delivering-rolls, and mechanism for moving them during unequal periods of time; Fig. 2, a sectional elevation on the line *x x*, Fig. 1; and Figs. 3 and 4, details, to be fully referred to hereinafter.

Each of the lower delivering-rollers, *a a'*, at the two ends of the head-stock of the mule, have at their outer ends pinions *b b'*, which, through idle-wheels *c c'*, move the pinions *d d'*, on the roving-drums *e e'*; and at their other ends these delivering-rollers have pinions *f f'*, which engage idle-wheels *g g'*, and turn pinions *h h'*, at the ends of the front rollers, *h h'*. The delivering-rollers *a a'* are provided with worms *i i'*, having notched hubs 2 3, to be engaged by spurs 4 5 on the toothed clutches 6 7, adapted to be moved at suitable intervals to engage the clutches with a rotating toothed sleeve, *j*, deriving motion in any usual way. In this instance the sleeve is rotated by the pinion *k* on the revolving shaft *l*.

The clutches are moved longitudinally on the roller-shafts by means of forks *m m'* at the ends of levers *n n'*, pivoted at 8 9, each of the said levers having a stud, 10, for the reception of the clocks *o o'*, or contrivances which regulate the duration of movement of the delivering-rollers, and these levers are provided each with a slot or notch, *p*, at its longer end to receive the arms 12 or 13, which, mounted loosely upon the shaft *r*, project into the slots *p*. Each of these arms 12 13 is moved forward by an arm, *t*, fixed on shaft *r*, each arm, *t*, being preferably provided with an adjusting-screw, *u*, to enable the arms *t* to act simultaneously upon the arms 12 and 13, and move them so as to simultaneously engage the clutches which drive the delivering-rolls, this action taking place at the inward run of the carriage, at which time the carriage, or a roller thereon, (shown in dotted lines, Fig. 2.)

strikes the arm *s*, fixed to and which operates the rock shaft *r*.

Catches *w w'*, pivoted on studs, 17 18, one for each catch, are turned by springs 19, having their ends 20 connected with the catches, so as to cause the catches to engage and hold the arms 12 13 when they are moved forward by the shaft *r* and arms *t* at each inward run of the carriage.

As the arms 12 13 are moved in the direction of the arrow, Fig. 2, the levers *n n'* are also moved, so to engage the teeth of the clocks *o o'* with the worms *i i'*; and so long as the catches hold the arms 12 13 the clutches are held in gear, the clocks rotate, and the two sets of delivering-rollers, one at each side of the mule, operate in unison.

Each catch *w w'* is or may be provided with an adjustable projection, *x'*, held by a screw, 22, against which strikes the adjustable time-pins 23, one on each rotating clock, (see Fig. 4,) the pin, by its action upon the projection *x'*, disengaging the catches from the arms, and permitting the springs 24 25 to throw the said arms backward, thereby removing the teeth of the clock from engagement with the worm *i'*, as shown at the right of Fig. 3, the clock *o'* at the left being in that figure shown in engagement with the worm *i*, its catch *w* not yet having been released. These arms and levers are operated simultaneously to throw the clocks *o o'* into engagement with the worms *i i'*; but they are disengaged at different times, in order that one series of rovings, those of least weight, may be delivered for a longer time than the heavier rovings during the outward movement of the carriage, and while the said heavier rovings are being stretched.

To accomplish this, the main object of my invention, I have provided each clock *o o'* with a series of holes, (see Fig. 4,) into any one of which the time-pins 23 may be placed, so that the said pins (the clocks returning to their normal positions after each inward run of the carriage) will act sooner or later, as may be desired, upon the projections *x'* of the catches, and release them from the arms 12 13 at different times, the release of either of said arms permitting the spring 24 or 25 connected with it to pull back the lever *n* or *n'* with which it co-operates, so as to release the catch *w* or *w'*, move the clock *o* or *o'* from its worm *i* or *i'*, and disengage the clutch 6 or 7, the delivering-rollers, governed as to the duration of movement by the clock, yet continuing to rotate, feeding out the smaller rovings, while the delivering-rollers for the largest rovings, already stopped, remain at rest, which permits the heaviest rovings to be stretched while the lightest rovings are being delivered, thereby making of equal weight the yarns or threads being spun from rovings of unequal weights. In this instance of my invention the clock *o'*, located at that end of the mule where the rov-

ings are lightest, first operates to stop the rolls *a' b'*.

The pin 27 in the clock acts as the stop to check the clock in its backward movement about the supporting-pin 10, when released from the worm which moves it forward, and the weighted cord 26 operates to turn the clock backward, so that the clock always starts from the same position to move forward.

By changing the position of pin 23, and placing it in one or the other of the series of holes in the clock, the number of rotations of each set of delivering-rolls *a b* or *a' b'* may be regulated according to the difference in the weight of the rovings.

The plates 30, when placed above the clocks, prevent the time-pins from being accidentally removed.

To place the number of revolutions of the delivering-rollers more accurately under control than could be done by the pins 23 alone, I have provided the projections *x'* with inclined faces; and by adjusting the said projections upon the catches, the pins 23 may be made to release the catches sooner or later from the arms 12 or 13.

When the pins are located alike in both the clocks, both sets of rolls will be stopped simultaneously in the usual way.

By providing for the adjustment of the pins 23, rovings of different size and weight may be spun simultaneously on the same mule and produce yarns of the same size and weight.

The relief-springs 15, one on each arm 12 13, act upon the levers *n n'* to move the clutches and clocks and worms into engagement, and prevent breaking of parts if the teeth do not fall into line.

Instead of the particular clutches and clocks shown, I might employ any other well-known mechanical equivalents for either of them, to operate as hereinbefore described.

This my invention is applicable to the well-known McGovern or to any other mule having delivering-rollers and a carriage, and the delivering-rollers may be of any usual construction, and be rotated by any usual devices.

In this specification I have provided for making yarn of uniform size from rovings of different sizes, by permitting one set of delivering-rolls to run longer than the other; but the same thing can be accomplished by making one set of rolls run faster than the other for the same length of time.

That plan of my invention forms the subject-matter of another application for patent, filed concurrently with this, to which reference may be had.

I claim—

In a mule having two independent sets of delivering-rolls, the combination, with mechanism for rotating the rolls, of a changeable clock or contrivance to arrest the movement

of one sets of rolls before the other set while the carriage moves outward to stretch the yarns, to adapt the mule to simultaneously spin rovings of different sizes or weight and produce therefrom yarns of uniform or like size and weight, substantially as described.

In testimony whereof I have signed my

name to this specification in the presence of two subscribing witnesses.

EBEN A. BALDWIN.

Witnesses:

J. LEONARD TATTERSALL,
DAVID HALLIDAY.