

G. M. BARONIDIS.
Hot Atmosphere and Medicated Bath.

No. 209,319.

Patented Oct. 29, 1878.

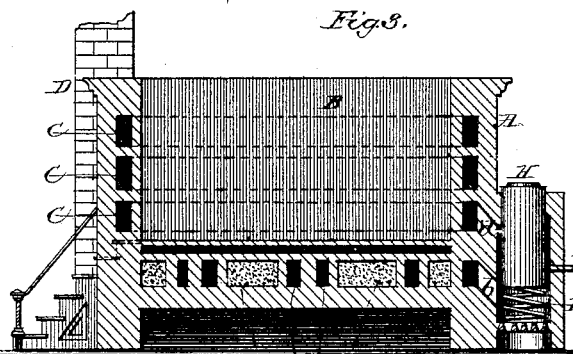
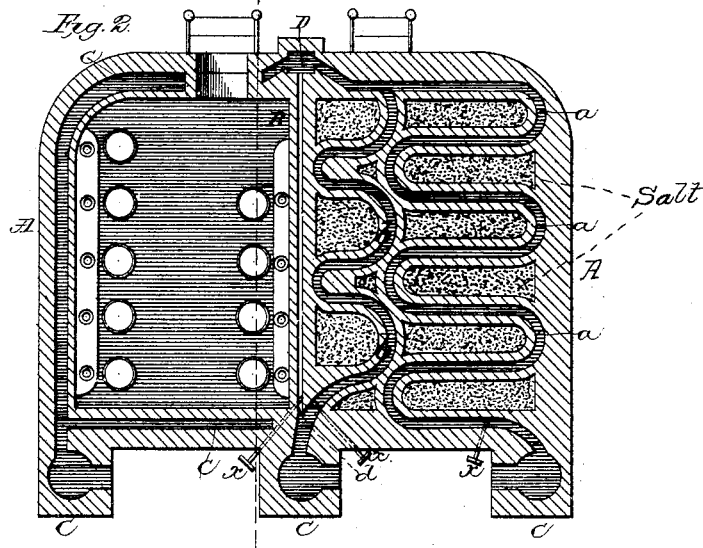
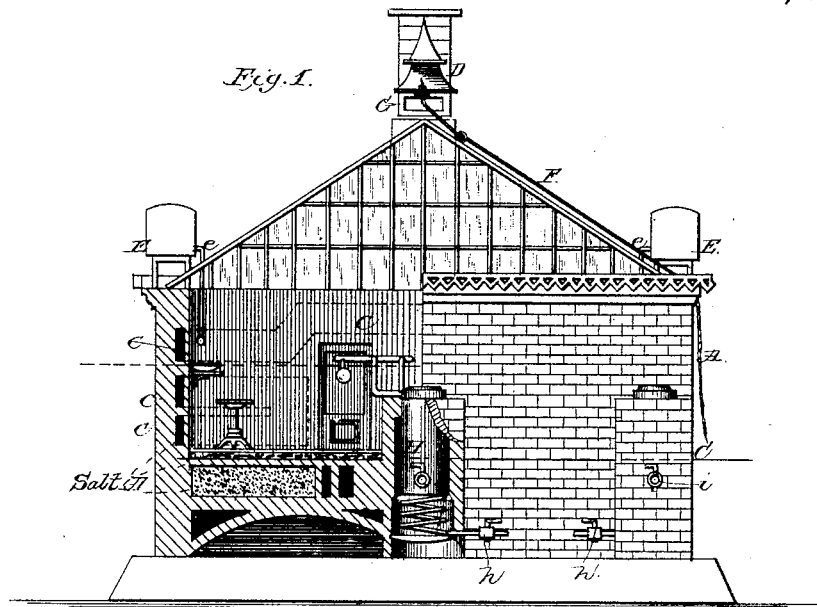

Witnesses:
Edward C. Osborn,
& Patten.

Inventor:
G. M. Baronidis
C. M. Smith
per Atty.

UNITED STATES PATENT OFFICE.

GEORGE M. BARONIDIS, OF SAN FRANCISCO, CALIFORNIA.

IMPROVEMENT IN HOT-ATMOSPHERE AND MEDICATED BATHS.

Specification forming part of Letters Patent No. **209,319**, dated October 29, 1878; application filed September 13, 1878.

To all whom it may concern:

Be it known that I, GEORGE M. BARONIDIS, M. D., of the city and county of San Francisco, in the State of California, have made and invented a certain new and useful Improvement or Invention in Hot-Atmosphere and Medicated Baths; and I do hereby declare that the following is a full, clear, and exact description of the manner of constructing and operating my invention, reference being had to the accompanying drawing and the letters and figures marked thereon.

These baths are generated by dry heat introduced through the walls and under the floor, all of which are built of brick.

By the means employed by me, the room in which the patients are treated is heated through the walls and floor, in which are built circuitous flues, through which the products of combustion from the furnace pass on their way to the exit.

A thickness of six inches of sea-salt in grain, which should be mixed with coarse gravel to prevent its crystallization by heat, will be laid over the floor, then covered over again with another brick floor two inches thick. These are divided into rooms containing chairs and several descriptions of fine wild flowers and herbs, each patient being buried in these up to his knees, wearing fine flannel shirts, thereby superinducing a thorough perspiration.

Each chair will have a basin with soft sponge to bathe the head with a compound of fresh vinegar distilled from the essence of flowers and herbs, thereby preventing the blood from rising to the head during the bath, the heat drawing out the rheumatic perspiration from the joints affected, and also from the skin of the bones. The patient, after having remained in the chair-bath for fifteen or twenty minutes, will then be transferred into a hot tub-bath composed of the essence distilled from wild flowers and herbs, washing off the perspiration on the skin acquired by the chair-bath, after which the patient will be frictioned with a prepared salve in order to close the pores and replace the natural elasticity of the limbs.

The above treatment will also cure newly paralyzed and all afflicted nerves, and will

draw out from the system all mercury which might have been previously absorbed.

In the said drawing herein referred to, Figure 1 is an elevation of my improved hot-atmosphere bath, with one part in section to show the construction of the interior. Fig. 2 is a plan view, and Fig. 3 is a transverse vertical section through the same, and through the furnace, hot-water coil, and boiler.

The object of my invention is to produce an improved hot-atmosphere bath room or building for the treatment of diseases in which heat is generated and used, in combination with medications of different kinds.

It consists, first, in constructing the walls and floor of the apartment with circuitous or snake-like flues, channels, or passages, which communicate with a furnace or furnaces and with a chimney-shaft; second, in securing a dry as well as a hot atmosphere by filling in the spaces between the channels or passages with salt, or equivalent absorbent material, and constructing the floor also with a layer beneath it of the same substance; third, in combining with the furnace or furnaces that furnish heat to the baths a hot-water coil and boiler for utilizing the heat from the fires and producing the necessary hot water for the subsequent bathing and treatment of the patients; and, lastly, in constructing the said room or apartment having circuitous or snake-like flues, channels, or passages through its walls and beneath its floors, with a glass roof for admitting sunlight into the room and bath, all which will be more fully described hereinafter.

The room or building A is made of brick, and when constructed on a large scale it is divided into compartments by a partition, B. Through the walls and partitions and beneath the floor are formed circuitous flues or snake-like passages or channels *a b c d*, which communicate with furnaces C C and lead from them to a chimney-shaft, D. These flues or passages act as conductors for the heat, flames, and gases of combustion from the furnaces, and by giving out heat to the walls and floor operate to produce a warm atmosphere within the room without admitting any direct heat or heated air from the fires. The degree of heat required is regulated by means of damp-

ers, (shown at *x x* in the drawing,) for controlling the flues, and by a ventilator at the top of the glass roof.

The walls and floor of the bath are kept dry and prevented from retaining moisture by means of a filling of sea-salt, or other equivalent absorbent, placed between the flues or passages in the walls and beneath the floor, and in constructing the floor this layer of salt or other equivalent substance is spread over the top to the depth of six inches, more or less, and a brick floor is then laid over it. Thus a dry as well as a warm atmosphere will be produced.

Within the apartment are placed chairs or seats for the patients, and at each seat is provided a basin or vessel to receive different medicated preparations and aromatic vinegar for bathing the head of the patient when the heated atmosphere affects that part. A reservoir, E, for holding this liquid and supplying it to the basins is located on the roof, and is connected with the interior of the apartment by tubes *e e*.

The building or room is inclosed by a glass roof, F, for admitting sunlight, and a ventilator, G, at the top, controlled from the outside by the attendants, is provided for regulating the degree of heat.

With each furnace C is combined and employed a hot-water boiler, H, having a heating worm or coil, I, which is situated in the fire-box, and inlet and outlet pipes *h i* supply the cold water to the coils and allow it to be drawn from the boiler when heated. By this means the necessary hot water for tub-baths and for subsequent ablutions of the patients is provided without using additional fires.

As thus constructed my invention is used and operated as follows: The fires are started in the furnaces, and the heat, flames, and gases, in passing through the flues or passages to the chimney-shaft, bring the walls and floor into a heated condition and produce a heated atmosphere within the room.

The floor of the bath is covered over about knee-deep with a layer of dried botanical herbs of various kinds, and the patient, divested of clothing, excepting a fine flannel shirt or under-garment, is placed in the room and seated upon one of the chairs, the layer of herbs covering the lower limbs up to the knees. A thorough perspiration is thus induced, and the medical properties thrown off

by the herbs when acted upon by the heated atmosphere are received and absorbed or otherwise act upon the patient while the pores are open.

The aromatic vinegar provided in the vessels is resorted to from time to time to bathe the head and preserve the equilibrium of the circulation, and after being treated in this manner for twenty or thirty minutes the patient is removed and bathed and otherwise treated to remove the results of the perspiration and close the pores.

Having thus fully described my invention, what I claim as new, and desire to secure by Letters Patent, is—

1. A bath room or building constructed with flues, channels, or passages in a circuitous manner through the walls and partitions and beneath the floor, and with the spaces between them filled with salt or other equivalent moisture-absorbing substance, substantially as herein described, said flues or passages being connected with a furnace or furnaces and with a chimney-shaft, substantially as and for the purposes herein set forth.

2. A hot-atmosphere bath room or building having its air heated by radiation from the walls and floors without the admission of direct heat or hot air, and having its floor covered with a layer of dried botanical herbs and flowers, substantially as herein described, for the purposes set forth.

3. A hot-atmosphere bath room or building composed and consisting of a room or apartments having circuitous flues, channels, or passages *a b c d* through and between the walls and beneath the floor, connected with furnaces C and with a chimney-shaft, D, and having a filling or layer of salt or other equivalent moisture-absorbent between and upon said flues or passages, a furnace or furnaces, C, with hot-water boilers and heating-coils combined therewith, for the purpose set forth, and a glass-roof covering and inclosing the said room or apartments, having a ventilator therein, all constructed substantially as herein described and set forth.

In testimony that I claim the foregoing I have hereunto set my hand and seal this 26th day of July, 1878.

G. M. BARONIDIS. [L. S.]

Witnesses:

C. W. M. SMITH,
WM. S. CAMPBELL.