

J. DALE.  
Paper-Ruling Machine.

No. 209,330.

Patented Oct. 29, 1878.

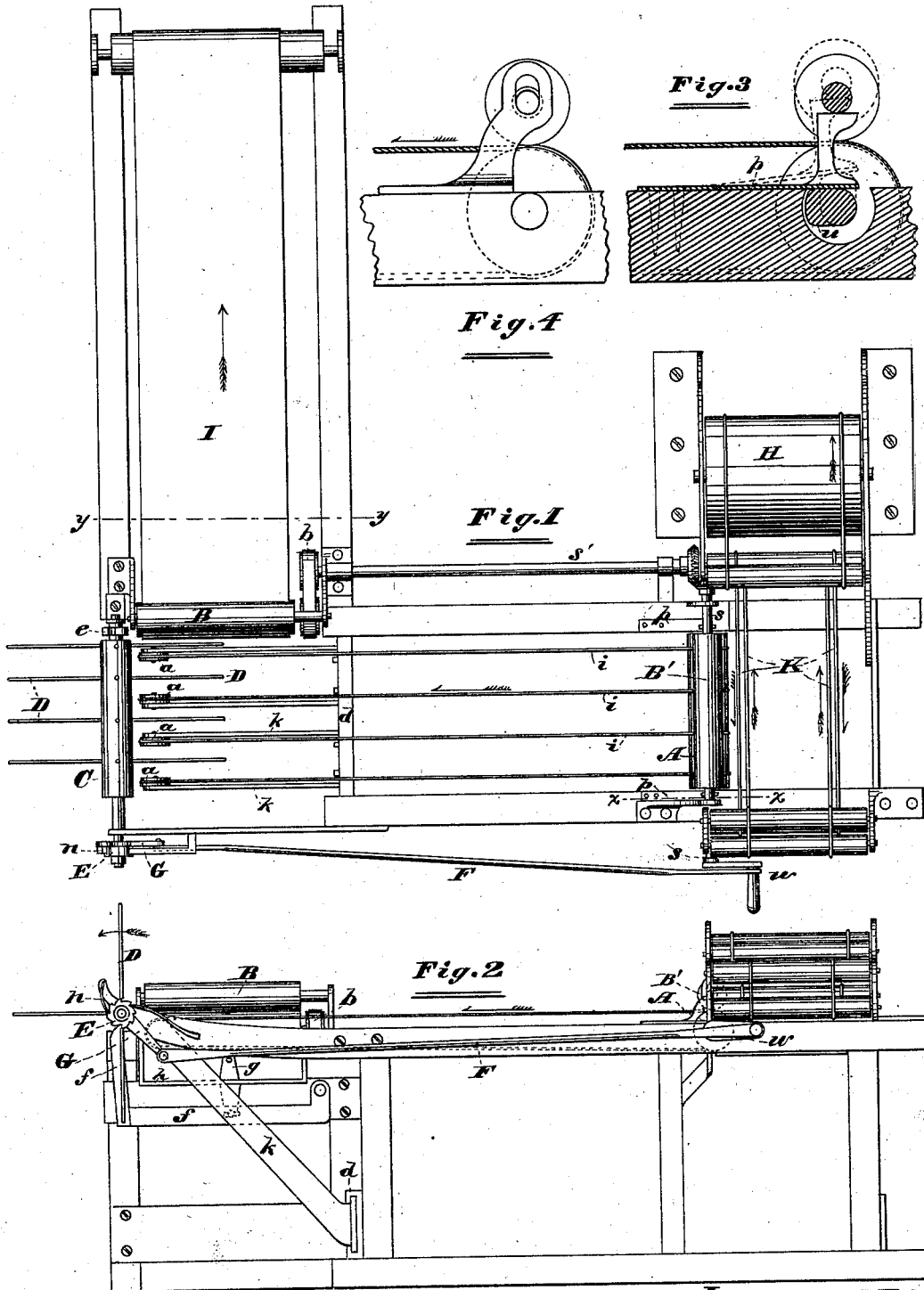

Attest:  
W. J. Baker  
A. R. Pl. nam

INVENTOR:  
James Dale,  
By R. Dydenfort,  
Attorney.

J. DALE.  
Paper-Ruling Machine.  
No. 209,330. Patented Oct. 29, 1878.

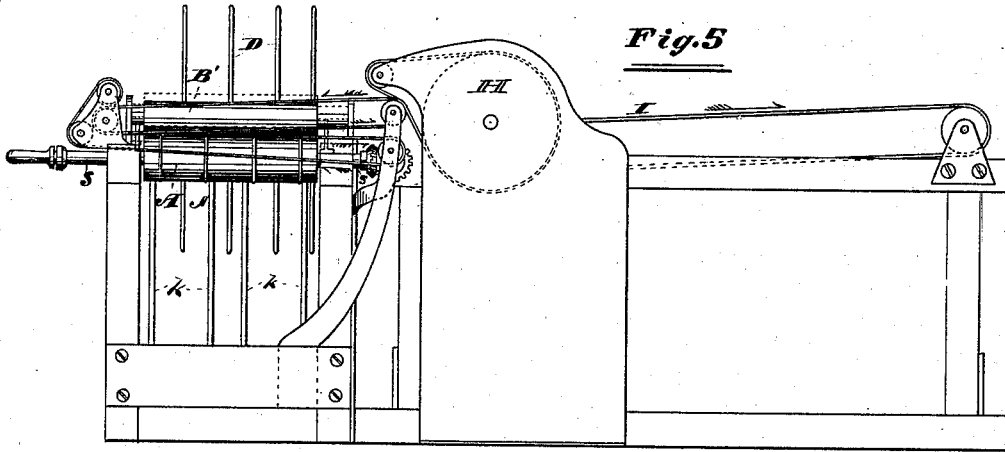

Fig. 5

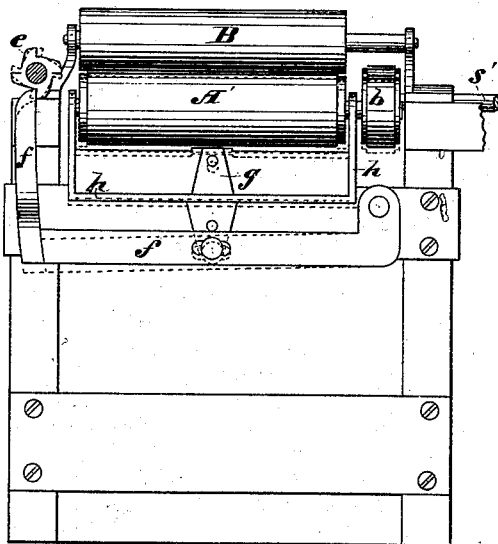

Fig. 6

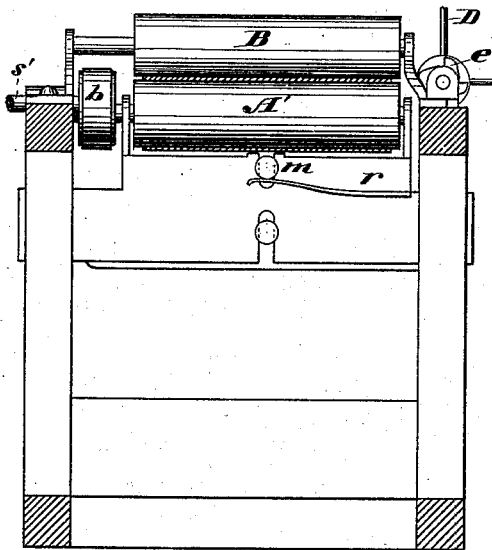

Fig. 7

Attest:  
*W. L. Baker*  
*A. R. Ohlmann*

INVENTOR:  
*James Dale*  
By *R. C. Dymenforth*,  
Attorney.

# UNITED STATES PATENT OFFICE.

JAMES DALE, OF CHICAGO, ILLINOIS.

## IMPROVEMENT IN PAPER-RULING MACHINES.

Specification forming part of Letters Patent No. **209,330**, dated October 29, 1878; application filed October 14, 1878.

### *To all whom it may concern:*

Be it known that I, JAMES DALE, of the city of Chicago, in the county of Cook and State of Illinois, have invented certain new and useful Improvements in Machines for Ruling Paper; and I hereby declare the following to be a full, clear, and exact description thereof, reference being had to the accompanying drawings, of which—

Figure 1 is a plan view of my machine, shown as attached to a printing-press; Fig. 2, a side elevation of the same; Fig. 3, a section on the line *x x*, Fig. 1; Fig. 4, an end view of the device which transfers the sheets from the printing-press to the ruling-machine; Fig. 5, an end view of the machine attached to a printing-press; Fig. 6, an end view of the latter half of the ruling-machine; and Fig. 7, a section on the line *y y*, Fig. 1.

Attempts have already been made, with some success, to contrive a machine for cross-ruling a sheet of paper on one side in one continuous operation—that is, without the labor and delay of feeding a second time. As early as the year 1854 such a machine was devised, in which the sheet, after being ruled in one direction, was received upon revolving drums arranged to carry it off at right angles and deliver it upon a second apron, moving at right angles with the first, which brought it into contact with a second series of pens, thus ruling it in the contrary direction also. It is obvious that in this case the sheets must be fed at a sufficient distance apart to enable each in its turn to get completely out of the way before the succeeding one reaches the drums, or whatever the device may be which changes its direction, (a distance necessarily somewhat greater than the dimension of the paper taken in the direction first ruled,) whereby a considerable loss of time is entailed.

The object of my invention is to overcome this defect by means of an improvement whereby the sheets may be fed in rapid succession, and nearly close together, without any danger of their interfering with one another at the turning-point, thus effecting a saving in the time ordinarily consumed of nearly one-half.

To this end my invention consists, first, in causing each sheet in its turn, after receiving

one set of lines in the ruling-machine, and upon reaching a given point, to be lifted bodily to a height sufficient to allow the succeeding one to continue on its course underneath, and then immediately to pass off at an angle upon a second carrier, which brings it into contact with pens suitably arranged for ruling the cross-lines; and, secondly, in certain devices and combinations whereby the above effects may be produced, all as hereinafter more fully set forth.

I shall proceed first to describe my ruling-machine as if it were wholly detached from a printing-press, since the said ruling-machine forms the leading and essential part of my invention, and its attachment to a printing-press is a subordinate feature and purely a matter of choice.

Referring to the letters of reference marked on the drawings, *i i i* are strings, forming an endless carrier and moving upon the roller *A* and wheels *a a*, the latter being supported upon oblique bars *k k*. The purpose of these bars is to permit the free and unobstructed action of the lifting-fingers, hereinafter referred to; and the said bars are best made laterally adjustable, in order that the spaces between the strings may be graduated as desired. I accomplish this by having their bases flanged and sliding in a guide, *d*, where they are held by set-screws.

*I* is a second endless carrier, forming an angle with the first, and generally, though not necessarily, a right angle, since the lines are usually, though not always, required to cross each other at right angles, and the two are arranged to run with equal speed, as follows: Power is applied at one end of the shaft *s* of the roller *A*. The opposite end of this shaft turns a second shaft, *s'*, at right angles to itself, by means of beveled gearing, and this second shaft, by means of a belt, *b*, or other suitable medium, turns the initial roller *A'* of the second carrier. Each carrier is supposed to move under pens, after the ordinary manner of ruling-machines.

The sheet of paper is fed upon the first carrier, over the roller *A*, and, after passing under the first set of pens, continues on to the end, where it is stopped by any suitable means. The purpose is now immediately to transfer it

to a higher level, so that the next sheet, which is supposed to follow it closely, may continue on its course uninterrupted until it, in its turn, reaches the stop, while the first sheet is drawn off by the second carrier and passed under the second set of pens, and so on indefinitely.

In order that the preceding sheet shall pass off upon the second carrier, it is necessary that the edge be caught at the proper moment between the roller A' and a roller, B, immediately above it, turning in a contrary direction, and so carried forward until it can be controlled by the carrier alone, when it is released, and the succeeding one, in turn, is caught and turned off in the same way. All this may be accomplished as follows:

C is a horizontal shaft, having fingers D D, projecting from it at suitable angles to one another. This shaft terminates in trunnions, which rest in suitable bearings upon the frame, the outer trunnion projecting beyond the bearing. At the extremity of this latter trunnion is a ratchet-wheel, E, rigidly fixed thereto, so that it can turn only with the shaft. Upon the shaft *s* is a crank, *w*, which imparts a reciprocating rectilinear motion to the rod F, which last, in turn, transmits an intermittent circular motion to the ratchet-wheel E, and hence to the shaft C, carrying the fingers D, by means of the pawl *n* at the end of the vibrating bar G. In this way, with each progressive impulse of the shaft C, a set of fingers is elevated to a plane a little above the level of the first carrier. Therefore, if a sheet is at the end of the first carrier it is lifted bodily by the fingers out of the way of the sheet following, and the latter is in the same manner lifted in its turn.

In order that the sheet of paper may, as aforesaid, be caught at the proper moment between the carrier-roller A' and the friction-roller B, I give to the roller A' a vertically-reciprocating motion by means of the cam-wheel *e*, so arranged upon the inner trunnion of the shaft C that at the proper moment it presses down the pivoted lever *f*, which is joined by a suitable arm, *g*, to the bearing-frame *h* of the roller A', thus depressing the top of the said roller A' below the level of the first carrier.

Upon being released by the cam the roller is thrown back to its original level by means of the spring *r* pressing against a stud, *m*, upon the connecting-arm *g*, when it engages with the friction-roller B.

The sheet should, of course, be placed upon the first carrier in such position that as it approaches the end its edge will project over the axis of the roller A', since otherwise it would not be caught between this roller and the friction-roller B and carried off to the second set of pens.

Mechanical movements other than those which I have shown and described may be substituted for the carrying out of my inven-

tion; but I find my devices capable of performing every necessary function when constructed and arranged with accuracy. I deem my invention, however, to be in a large measure independent of the mechanical details employed for its embodiment.

As hereinbefore stated, my ruling-machine may be attached to a printing-press and receive the sheets therefrom automatically. The drawings illustrate one way in which this may be done.

H represents a cylinder-press, from which, by means of a suitable carrier, K, each sheet is conveyed to the ruling-machine. As in the case of the turning-point in the latter, the sheet must be so placed as to project over the axis of the roller which changes its direction.

B' is a friction-roller, placed over the roller A in slotted journals, as shown in Fig. 4, and arranged to have a vertically-reciprocating action by means of cam-projections *u* at each end of the shaft of the roller A, which regularly lift and release it through the medium of the lugged springs *p*.

It is obvious that the motive power may (and should, that the whole may work uniformly) in this case act upon the printing-press, and be transmitted to the ruling-machine by a belt or by gearing. In order that the sheets may still be fed close together when a printing-press is used in connection with the ruling-machine, it is obvious that at the point of transfer a lifting device similar to that shown in the ruling-machine may be employed.

What I claim as new, and desire to secure by Letters Patent, is—

1. The mode of cross-ruling a sheet of paper on one side in one continuous operation, which consists in feeding it to the first carrier, where it receives one set of lines, and upon its reaching a given point lifting it bodily from the first carrier out of the way of the succeeding sheet, allowing this to continue on its course underneath, and passing it at an angle to the second carrier, where it receives the other set of lines, substantially as set forth.

2. In a machine for ruling paper, the combination of two carriers and a lifting device, arranged as described, whereby each sheet, in its turn, after receiving one set of lines on the first carrier, upon reaching a given point is lifted bodily out of the way of the succeeding sheet, and is then drawn off at an angle upon the second carrier, where it receives the cross-lines, substantially as set forth.

3. The shaft C, carrying the fingers D, and connected with the driving-power by mechanism, substantially as described, transmitting to it an intermittent circular motion, whereby the sheets are consecutively lifted, in combination with two carriers, at an angle to each other, as set forth.

4. The combination of the shaft C, provided

with the fingers D and having an intermittent circular motion, roller A', having a coincidently-intermittent vertically-reciprocating motion, and friction-roller B, substantially as described, for the purpose set forth.

5. The combination of the cam-wheel *e* upon the shaft C, pivoted lever *f*, connecting-arm *g*, having a stud, *m*, pressing against a spring,

*r*, and bearing-frame *h*, substantially as described, for transmitting a vertically-reciprocating motion to the roller A'.

JAMES DALE,

In presence of—

FRED. LEHMANN,  
MICH. PETRIE.